

Full Height Turnstile User Manual

Applicable Models: FHT 2300 / 2400

Version: 1.0 Date: Mar. 2017

Contents

Chapter 1 Product Introduction.....	1
1.1 Model number and access control.....	1
1.2 Mainframe-box and dimensions.....	1
1.3 Mechanical system of the FHT2000 series.....	2
1.4 Electronic control system.....	2
1.5 The working principle of full height turnstile.....	2
1.6 Product related parameters.....	3
Chapter 2 The installation of the product.....	4
2.1 Installation notes.....	4
2.2 Installation position of the full height turnstile.....	4
2.3 Cables Installation and Fixation.....	5
Chapter 3 Menu operation.....	8
3.1 Menu operation.....	8
3.3 Menu operation and description.....	8
3.4 System menu description:.....	9
Chapter 5 Product maintenance.....	11
5.1 Mainframe-box maintenance.....	11
5.2 Movement maintenance.....	11
5.3 Power maintenance.....	11

Chapter 1 Product Introduction

1.1 Model number and access control

Access Model	No	C3-200 with two KR101E reader	inBIO260 with two FR1200/ID reader
FHT2300	✓		
FHT2311		✓	
FHT2322			✓
FHT2400	✓		
FHT2411		✓	
FHT2422			✓

1.2 Structures and dimensions

FHT2000 series has stainless steel casing, which provides corrosion resistance and durability.

FHT2300's appearance and dimensions are as shown in figure 1-2A:

FHT2400's appearance and dimensions are as shown in figure 1-2B:

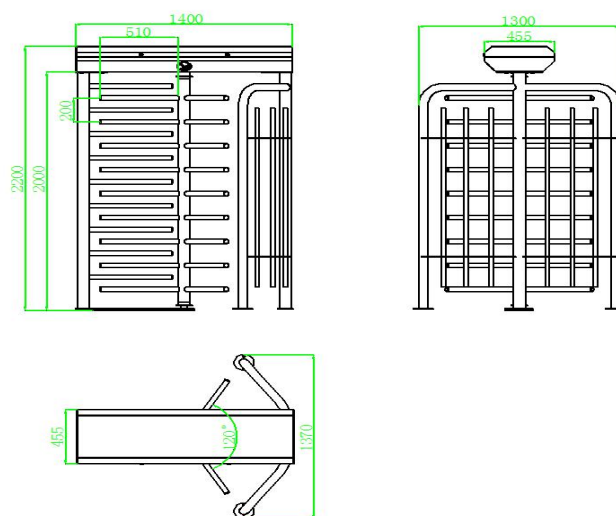

Figure 1-2A

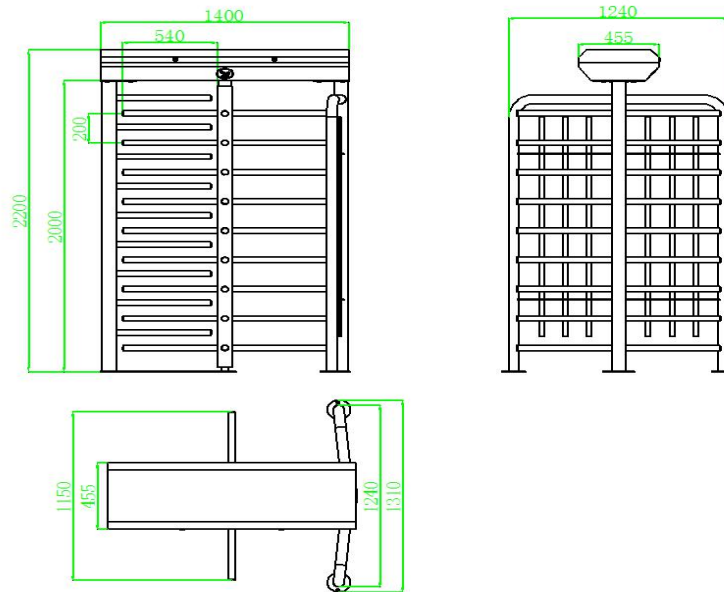

Figure 1-2B

1.3 Mechanical system of FHT2300&FHT2400 series

The mechanical system of the full height turnstiles includes a mainframe box and a frame. The direction indicator, core, control panel, access controller and lock are installed in the mainframe box. The core component mainly consists of a electromagnet, a spring and a transmission mechanism. The frame supports the entire mainframe box.

1.4 Electronic control system

The electronic control system of the full height turnstile is composed of reader, control panel, access controller, direction indicator, horn, and transformer.

Reader: The reader reads the data from the card and sends it to the controller.

Control panel: The control panel is the system's control center that receives signals from the controller. After the signals have been processed by the control panel, the control panel will deliver commands to the indicator. .

Direction indicator: This indicator displays the current status of the sign at the channel, and directs the pedestrian to pass the channel.

1.5 The working principle of full height turnstiles

1.5.1 After the power is turned on, the system will perform self check. If no fault is detected,

the device will operate as usual. If a fault is detected, the system will display the related messages on the LCD screen. This can be useful for error checking and troubleshooting.

1.5.2 When the reader detects a valid signal, the buzzer will give pedestrians a voice prompts to remind pedestrians has been successful credit card. And then, the reader sends signals to the access controller to request permission to pass through the passage. After the access controller send the signals to the control panel, the control panel will send out a pass.

1.5.3 After receiving the signal from the access controller, the control panel sends signals to the direction indicator and electromagnet. Then the direction arrow will turn green. Also the electromagnet will loose that the pedestrian can push the rod to pass the passage.

1.6 Product related parameters

Dimensions(mm)	FHT2000: L = 1400, W = 1310, H = 2200 FHT2400: L = 1400, W = 1370, H = 2200		
Communication Interface	RS232	Input voltage	AC 100 - 120V/200 - 240V, 50 - 60Hz
Input control signal	Switching signal	Output voltage	DC 24V
Working environment	Indoor/Outdoor	Relative humidity	5% - 10%
Temperature	-28°C ~ 60°C	Pass speed	RFID: Maximum 30/minute Fingerprint: Maximum 25/minute Face: Maximum 15/minute Vein: Maximum 15/minute

Chapter 2 The installation of the device

2.1 Installation notes

2.1.1 It is recommended that the full height turnstile should be installed on a cement platform with 50mm to 100mm in height.

2.1.2 It is recommended that the full height turnstile should not be used in corrosive environments.

2.1.3 Make sure the earth wire of the system is connected reliably to prevent any personal injuries or other accidents.

2.1.4 After completion of the installation, check the connection condition of earth wire, connector assembly for connecting line and all moving parts with the device. Make sure the connection is firm in order to prevent failure caused by long time operation. If any screw or part is not tightened, please tighten.

2.2 Installation position of the full height turnstile

The installation position are subject to the size of the full height turnstile, as shown in figure 2-2A and figure 2-2B.

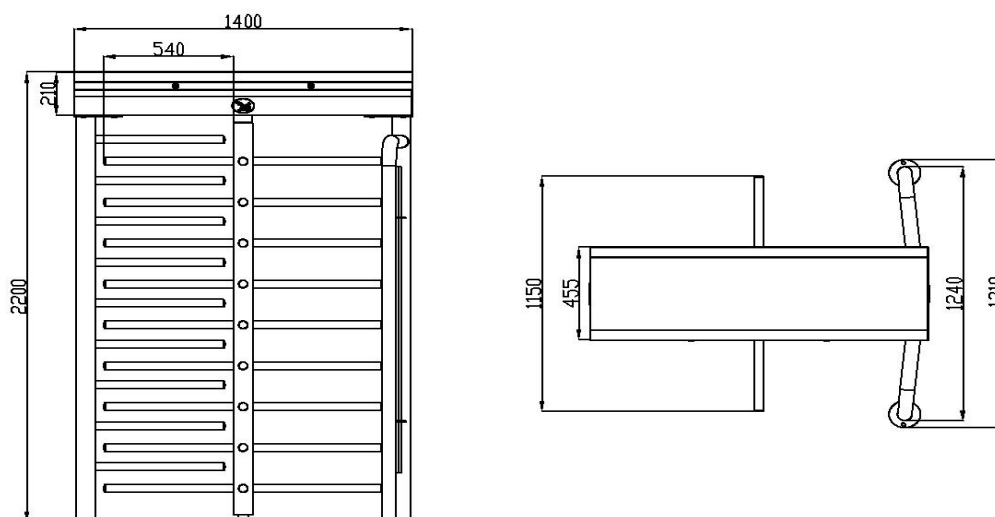

Figure2-2A

2.3 Installation and Fixation of Cables

The following diagram shows the interface of the concealed cable. The input voltage for this full height turnstile is AC100-120V/200-240V. The PVC conduits are buried 100mm below the ground, with the height of the exposed part not less than 100mm. To prevent water leakage to the conduit, the conduit mouth needs to be bent back.

FHT2300&FHT2400 series installation holes and cabling positions are as shown in Figure 2-3A and Figure 2-3B.

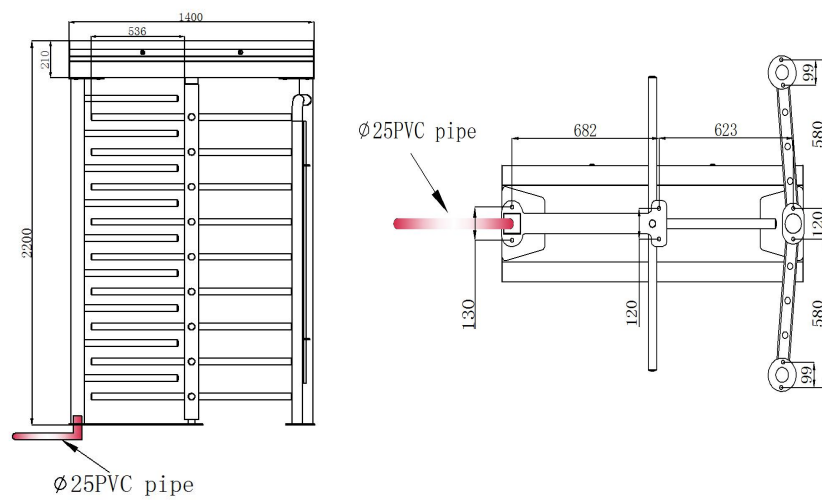

Figure2-3A

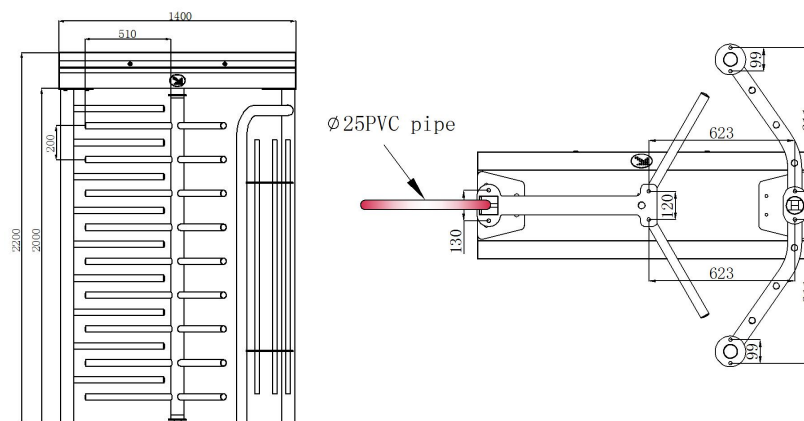

Figure2-3B

Put the installation diagram on the floor. Using percussion to drill holes for M12 screws on the corresponding position. Then install the screws to the corresponding positions. Next, place the frame on top of the screw and fix it. After that, the mainframe-box is fixed on the frame. Finally install the whole rotating part in the middle of the frame as shown in figure 2-3C.

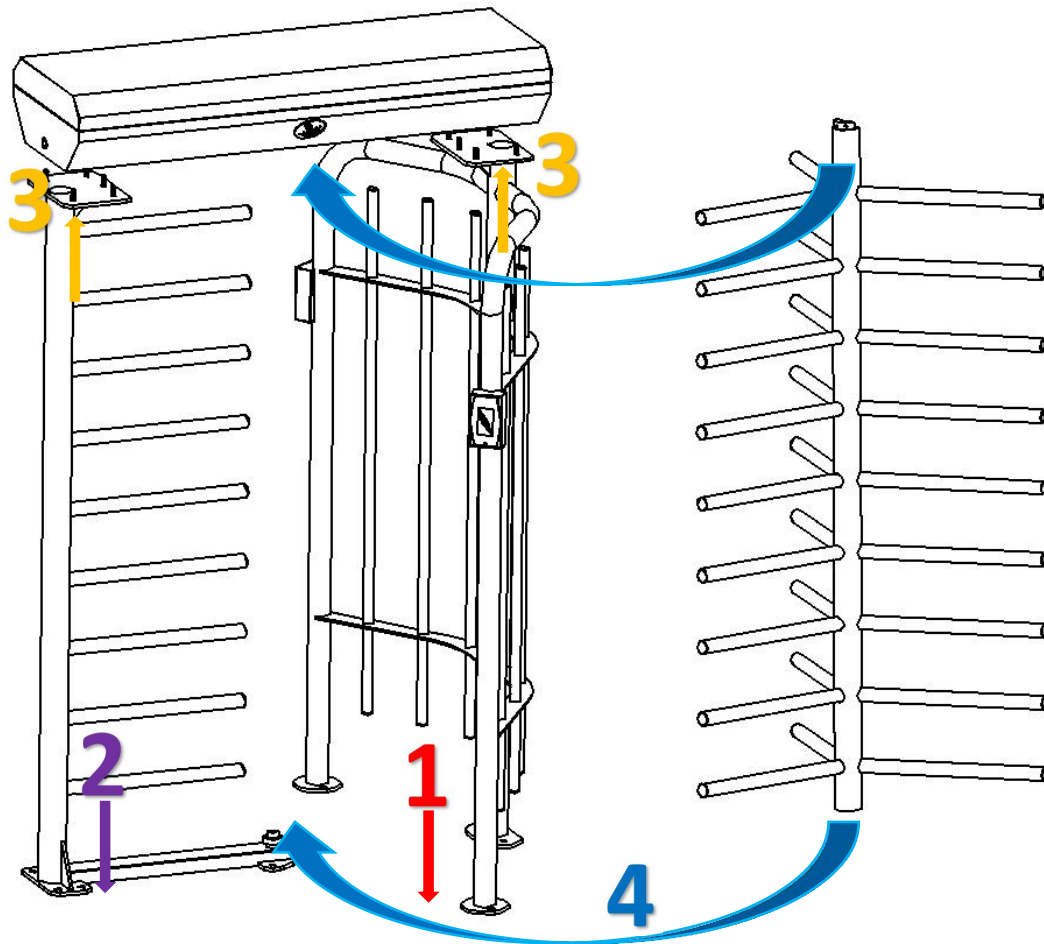

Figure2-3C

After fixing the device, open the mainframe-box to connect power wire and reader. Pull out the reader and power cord from both sides of the column and connect to the corresponding interface. Wiring diagram is as shown in figure 2-3D.

Full Height Turnstile Internal Wiring

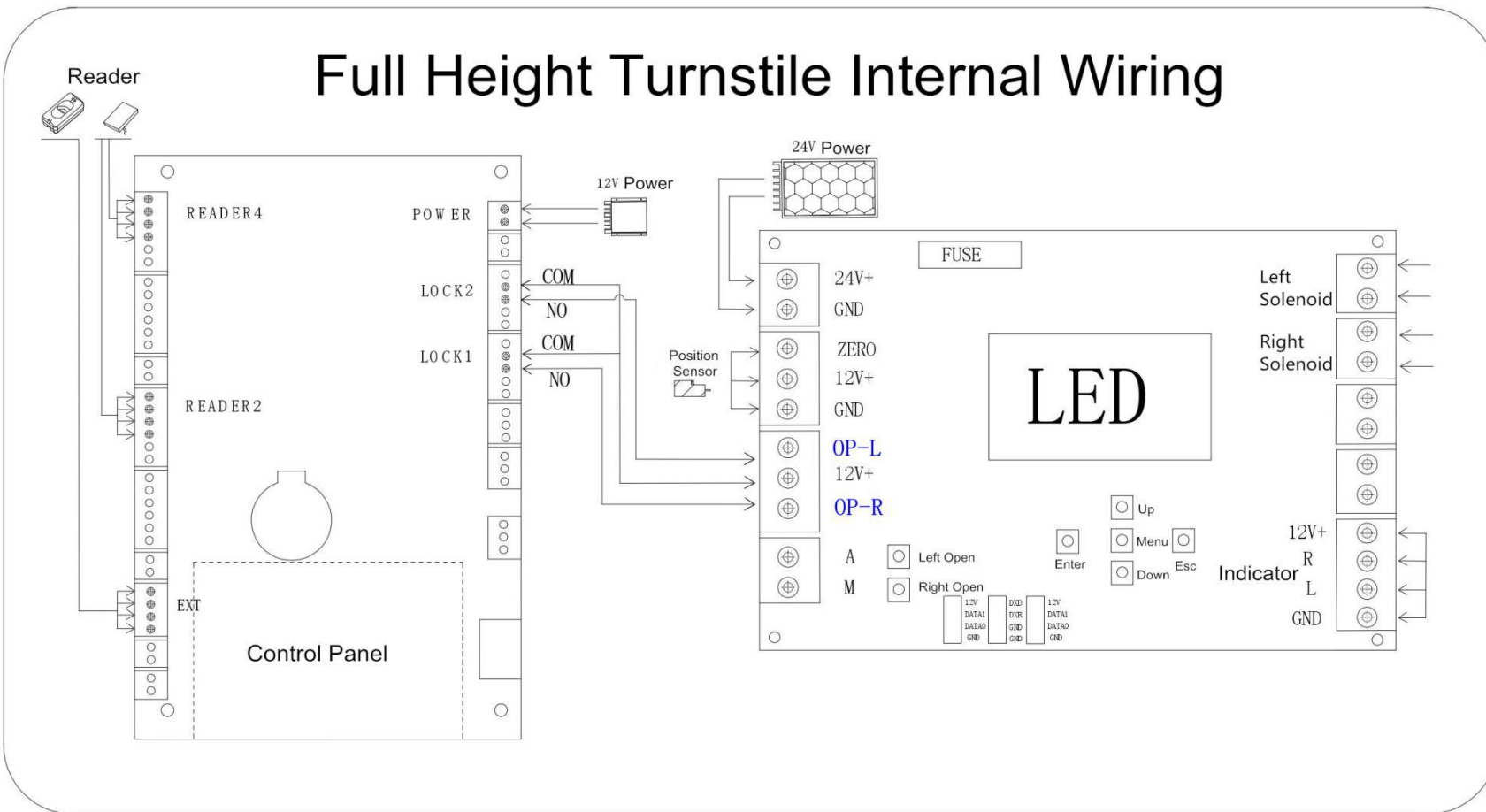

Figure2-3D

Chapter 3 Menu operation

3.1 Menu operation

1. After start-up, the LCD screen will display the current working mode.
2. There are 7 buttons on the panel: "LEFT OPEN", "RIGHT OPEN", "MENU", "UP", "DOWN", "OK" and "ESC".
3. There is a RS232 communication Interface on the panel that can send a signal to the panel.

3.2 Button Instruction

LEFT OPEN: Open the device to right.

RIGHT OPEN: Open the device to left.

MENU: Display the functions.

UP: Move up menu or add value.

DOWN: Move down menu or reduce value.

OK: Use to enter the menu item settings or to confirm the current value.

ESC: Use to return to the previous menu or cancel the current operation.

3.3 Menu operation and description

Press the "MENU" button, enter the password input interface, the default password is: "UP" key press two times, "Down" key press four times, and then press "OK" to enter the menu interface. If the operation is incorrect, press the ESC button go back to the previous menu, After entering the menu, press "UP" and "DOWN" to select a function and then press "OK" to enter the function. Finally press "UP" or "DOWN" to change the value, and then press "OK" to confirm.

3.4 System menu description:

1. Device mode

(1) Full height turnstile

2. Direction Setting

① → exit, entry ←

② → entry, exit ←

The setting of the sides for entry or exit. "→ exit, entry ←" means that right side is exit and left is entry. "→ entry, exit ←" means that right side is entry and left side is exit. The default setting is "→ exit, entry ←".

3. Passage Control

① → Y, N ←

② → N, Y ←

③ → N, N ←

④ → Y, Y ←

The setting for whether both sides of the machine (entry and exit) are allowed to pass. "→ Y, N ←" stand for being allowed on the right and forbidden on the left. "→ N, Y ←" stand for being forbidden on the right and allowed on the left. "→ N, N ←" stand for being forbidden on both sides. "→ Y, Y ←" stand for being allowed on both sides. The default setting is "→ Y, Y ←".

4. Open duration

Press "UP" and "DOWN" buttons to adjust time. Press "OK" to save. After the device is started, it will automatically close if no one passes. The default setting time is 5 seconds.

5. Open Delay

Press "UP" and "DOWN" buttons to adjust time. Press "OK" button to save.

Set the delay time of opening turnstiles. The default delay time is zero seconds.

6. Reset Counters

Resetting the entry / exit passing counter.

7. System Initialization

After successful initialization, the panel parameters will be restored to the factory setting and the entry / exit passing counter will be reset.

8. Device number

Press "UP" and "DOWN" buttons to adjust values. Press "OK" button to save.

When plural devices are placed together, different device number can be used to distinguish, the default number is 1.

8. Device information

The basic information of the display panel includes type and version etc.

9. Auto test

Repeated left and right switches, it is mainly used to test the stability of the control board and the ageing of device.

Chapter 5 Product maintenance

5.1 Mainframe-box maintenance

The mainframe-box is made of 304 stainless steels. So after a long period of operation, its surface may have some stains. It can use gauze to clean the mainframe-box. In order to protect the lines of surface, please wipe along the lines direction. It's best to polish and wax.

5.2 Movement maintenance

Cut off power supply before maintenance. Open the barriers and clean the dust on surface, add lubricating oil to the transmission mechanism. Check and tighten others connection parts.

5.3 Power maintenance

Cut off power supply before maintenance. Check whether the plug is loose, if loose, it needed to tightly it. Please do not replace the connection position at random. Check whether the external power supply is exposed and wrap it. Check whether there is any leakage, found to be timely processing. Check the technical parameters at the interface are regular and replace the old electronic components in time.

(Attention: Above full height turnstile maintenance must be maintained by professional personnel. Especially the movement and the electric control part, first cut off the power supply, ensure the operation safety.)