

Single Energy X-ray Inspection System

ZKX5030A

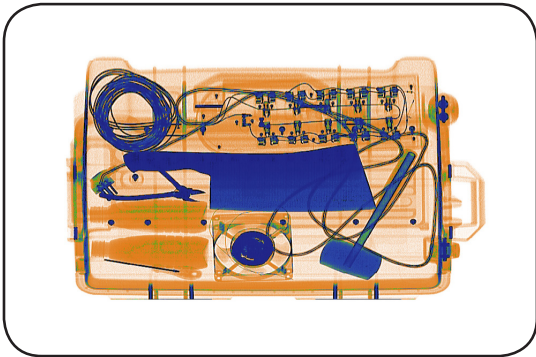

Highlights

- Pseudo-color image
- Widely usable for carry-on baggage
- Excellent, ergonomic industrial design

Introduction

ZKX5030A X-ray inspection system increases the operator's ability to identify potential threats; the device is designed to scan briefcases, carry-on baggage, small cargo parcels.

ZKX5030A uses reliable high quality single energy X-ray generator. With the superb image algorithm, ZKX5030A could offer clear scanning image, which allows operators to identify potential threat items visually.

With ergonomic modern design, ZKX5030A could help operators to identify suspicious items fast and accurately.

** Kindly note: ZKX5030A equipped with a computer keyboard*

Specifications

Tunnel Size	507mm (Width) * 305mm (Height)
Speed	0.20m/s
Height of Transmission Belt	710mm
Maximum Load	≥150kg (Adequate distribution)
Wire Resolution	≥34AWG (0.16mm metal wire)
Space Definition	Horizontal Φ1.0mm \ Vertical Φ2.0mm
Penetrate Definition	≥32AWG
Penetration	≥8mm Steel board
Monitor	17inch LED
System Function	High density alarm, TIP, Luggage counter, System running timer, X-ray emitting timer, System maintainance, Training
Optional Function	Video surveillance system, Bidirection scan, Electrical weighing system, Energy saving mode, Ultrasonic rat repellent
Flim Safety	ASA/ISO1600 standard of film safety

X-ray System

Tube Voltage	80Kv
Cooling	Seal oil cooling / 100%
Single Inspection Dosage Rate	≤1.0μ Gy
Radiation Leak Dosage	0.1μ Gy/h(5cm from the surface)

Installation Specification

Package Size	1970mm(Length)×1020mm(Width)×1420mm(Height)
Weight	400KG
Power Consumption	0.6kVA
Noise	53.8dB(A)

Dimension

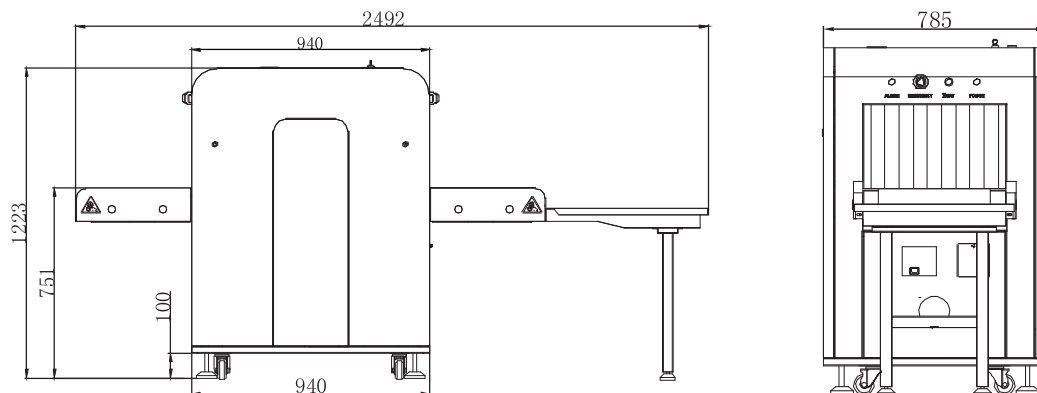

More details

ZKTECO CO.,LTD.
www.zkteco.com
E-mail: sales@zkteco.com

© Copyright 2016. ZKTECO CO., LTD. ZKTECO Logo is a registered trademark of ZKTECO or a related company. All other product and company names mentioned are used for identification purposes only and may be the trademarks of their respective owners. All specifications are subject to change without notice. All rights reserved.

