

User Manual

InBio-160 PoE Bundle

Version: 1.0

Date: June, 2016

About this Manual:

This manual introduces the installation connection and user manual of the PoE access control panel.

Table of Contents

1 Important Security Instructions	1
1.1 Important Security Instructions	1
1.2 Installation Cautions.....	2
2 Introduction	5
2.1 System Function Parameters.....	5
2.2 Product Technical Parameters.....	5
2.3 Indicators Description.....	6
3 Connection and Installation.....	8
3.1 Panel Box Installation	8
3.2 Installation and Wiring.....	9
3.3 System Structure.....	10
3.4 Connection Terminals.....	11
3.5 Connection with External Accessories.....	12
3.6 Connection with Readers.....	14
3.7 Relay Output Connection	15
3.8 PoE Power Supply Structure.....	18
4 System Networking.....	19
4.1 System Wiring and Wires Requirements.....	19
4.2 TCP/IP Network Communication.....	20
4.3 RS485 Network Communication.....	21
4.4 DIP Switch Settings	22

1 Important Security Instructions

1.1 Important Security Instructions

1. Read, follow and keep the instructions: Before operating the equipment, read and follow strictly all security and operation instructions. Please keep the instructions for reference.

2. Accessories: Please use the accessories recommended by the manufacturer or delivered with the product. Any other related product is not recommended as the major alarming or monitoring system. The major alarming or monitoring system should comply with the local applicable fire-prevention and security standards.

3. Installation cautions: Do not place this equipment on any unstable table, tripod mount, support or base to prevent the equipment from falling and becoming damaged, or worse, cause severe personal injury. Therefore, it is important to install the equipment as instructed by the manufacturer.

4. All peripheral devices must be grounded.

5. No external connection wires can be exposed. All connections and idle wire ends must be wrapped with insulating tapes to prevent accidental contact with exposed wires and damaging the equipment.

6. Repair: Do not attempt unauthorized repair of the equipment. Disassembly or detachment is likely to cause shock or other risks. All repair work should be done by qualified repair personnel.

7. Damages in need of repair: In any of the following cases, first disconnect the AC/DC power supply from the equipment and notify qualified repair personnel for repairs:

- ✧ If the power cord or connector is damaged.
- ✧ If there is presence of liquid or any other foreign object into the equipment.
- ✧ If the equipment is wetted or exposed to bad weather (rain, snow, etc.).
- ✧ If the equipment does not work properly even though it is operated as

instructed. Please be sure to adjust only the control components specified in the operation instructions. Incorrect adjustment of other control components may cause damage to the equipment, and add to troubleshooting complexity for the qualified technicians.

✧ If the equipment is dropped or its performance noticeably changes.

8. Replacing components: If it is necessary to replace a component, the repair personnel must use only the substitutes specified by the manufacturer.

9. Security inspection: After the equipment is repaired, the repair personnel should conduct a security inspection to ensure the equipment is working properly.

10. Power supply: Operate the equipment with only the type of power supply indicated on the label. Contact the operator for any uncertainty about the type of power supply.



Violation of any of the following cautions is likely to lead to equipment failure or even personal injury.

- Before installation, switch off the external circuit (that supplies power to the system), including lock power.
- Before connecting the equipment to power supply, ensure the output voltage is within the specified range.
- Never connect power before completion of installation.

1.2 Installation Cautions

1. The conduits of wires under relay must be matched with metaled conduits, other wires could use PVC conduits. to prevent failure caused by rodent damage. Although a control panel is designed with good antistatic, lightning-proof, and leakage-proof functions, ensure its chassis and the AC ground wire are connected properly and the AC ground wire is grounded physically.

2. It is recommended to not plug/unplug connection terminals frequently when the system is energized. Be sure to unplug the connection terminals before

starting any relevant welding job.

3. Do not detach or replace any control panel chip without authorization, because unprofessional operation may cause damage to the control panel.

4. It is recommended to not connect any other auxiliary devices without permission. Before all non-routine operations, must communicate with our engineers in advance.

5. A control panel should not share one power supply with any other large-current device.

6. It is recommended that readers and buttons be installed at heights of **1.4-1.5m** above the ground, but the heights may be adjusted according to the customers' usual practice.

7. The appliance shall be installed and wired in accordance with national electrical code and by qualified personnel only.

8. It is advised to install control panels at places easy of maintenance, like a **weak electric well**.

9. It is strongly recommended that the exposed part of any connection terminal should **not be longer than 4mm**, to avoid short-circuit or communication failure resulting from accidental contact with excessive exposed wires.

10. To save access control event records, download data periodically from control panels.

11. Prepare for unexpected power failure according to application situations like **connecting power supply with UPS**.

12. For InBio reader (biometric fingerprint reader, collect the fingerprint only, all the other operations such as storage, verification and etc. execute in the control panel) connections, if the reader shares the power with the control panel, it is recommended that the wire **should be less than 100 meters**. If you need to use in the longer distances, please use a separate power supply.

13. The connection between a PC and a control panel should be less than 1200m for RS485 communications. A length **of 600m** or less is recommended to increase communications stability.

14. To protect the Access Control System against self-induced electromotive

force generated by an electronic lock at the moment of switching off/on, it is necessary to **connect a diode in parallel** (please use the FR107 delivered with the system) with the electronic lock to release the self-induced electromotive force.

15. It is recommended that an electronic lock and a control panel should **use respective power supplies**.

16. It is recommended that the power supply included with the system be used as the control panel.

17. In a place with strong magnetic interference, galvanized steel conduit or shielded cables are recommended, and proper grounding is required.

18. Only be installed by professionals.

2 Introduction

The Access Control Management System is a new modernized security management system that is an effective measure for security and protection management. It is mainly used to manage entrances and exits of secured locations such as banks, hotels, equipment rooms, offices, smart communities, and factories.

2.1 System Function Parameters

- High-speed 32-bit 400MHz CPU, 32M RAM, and 256M Flash.
- Embedded LINUX operating system.
- InBio-160 supports one-door one/two way
- A maximum of 30,000 card holders, 3,000 fingerprints and 100,000 offline event records.
- Support of multiple Wiegand card formats and a password keypad, compatible with various types of cards.
- Use of dual communication technologies: The Ethernet and the RS485 industrial bus for reliable communications.
- A watchdog (hardware) built in the control panel to prevent crash.
- Over-current, over-voltage, and inverse-voltage protection for input of power supply to the control panel.
- Over-current protection for the power supply to card readers.
- Instant over-voltage protection for all input/output ports.
- Instant over-voltage protection for communication ports.

2.2 Product Technical Parameters

- Working power supply: Rated voltage 12V ($\pm 20\%$) DC; Rated current $\leq 0.5A$.
- Working environment: Temperature $0^{\circ}C-55^{\circ}C$; humidity 10%-80%.
- Electronic lock relay output: The maximum switching voltage: 36V (DC); The maximum switching current: 5A

- Auxiliary relay output: The maximum switching voltage: 36V (DC); The maximum switching current: 2A

- With detachable connection terminals made of alloy-steel non-magnetic flange materials.

- Outline dimensions of the control panel: InBio-160: 185.1mm (length) × 106mm (width) × 36mm (thickness)

- External box dimensions: 305.2mm × 298.4mm × 89mm

2.3 Indicators Description

When the InBio-160 is powered on, normally the POWER indicator (red) is lit constantly, the RUN indicator (green) flashes (indicating the system is normal), and other indicators are all off.

Except the cases as following cases:

1. LINK indicator (green): Constant Light indicates TCP/IP communication is normal;
2. ACT indicator (yellow): Flashing indicates data is in transmitting through TCP/IP communication;
3. EXT RS485 indicator (yellow & green): Flashing indicates it is sending or receiving data through external RS485 communication;
4. PC RS485 indicator (yellow & green): Flashing indicates it is sending or receiving data through PC RS485 communication;
5. CARD indicator (yellow): Flashing indicates a card is punched on reader.

See the indicators in the following figure:

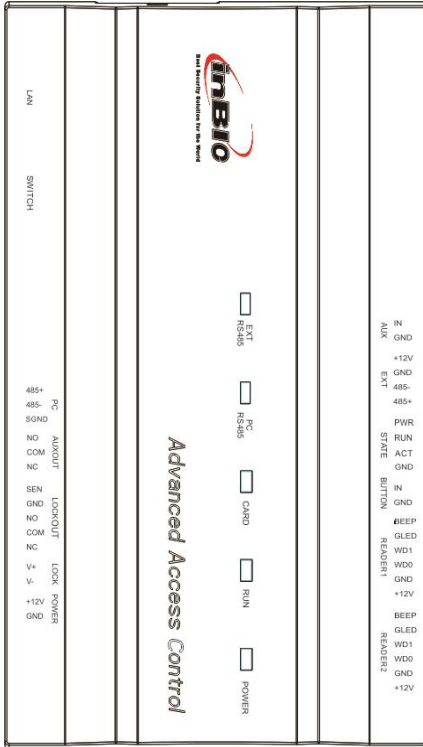

Indicators in the InBio-160

3 Connection and Installation

3.1 Panel Box Installation

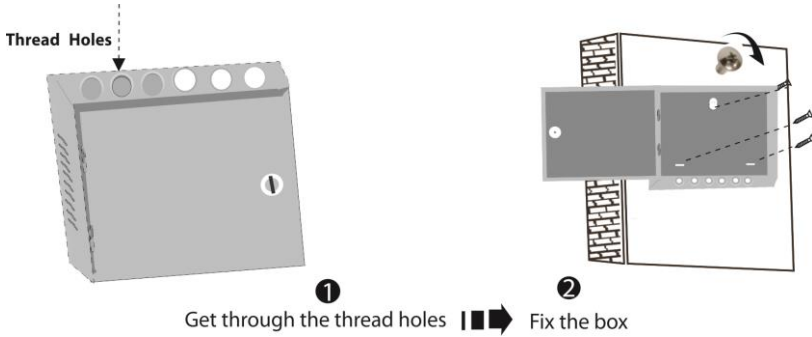

Access Control Panel

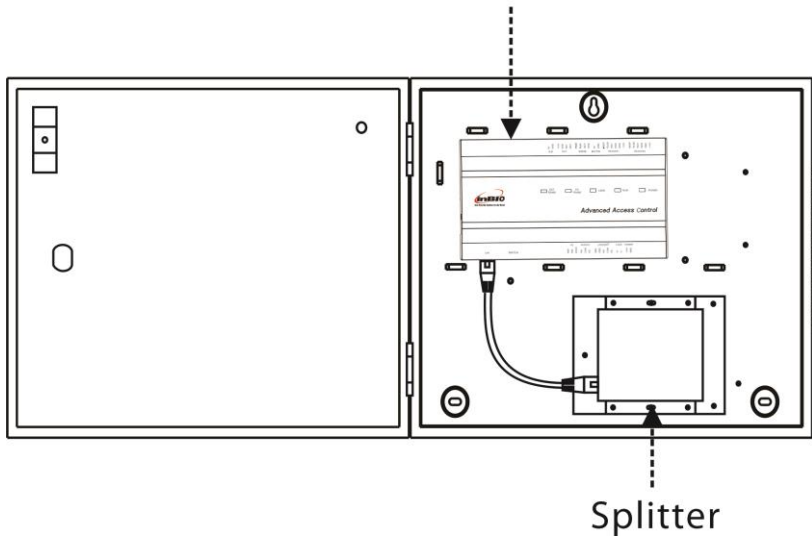

3.2 Installation and Wiring

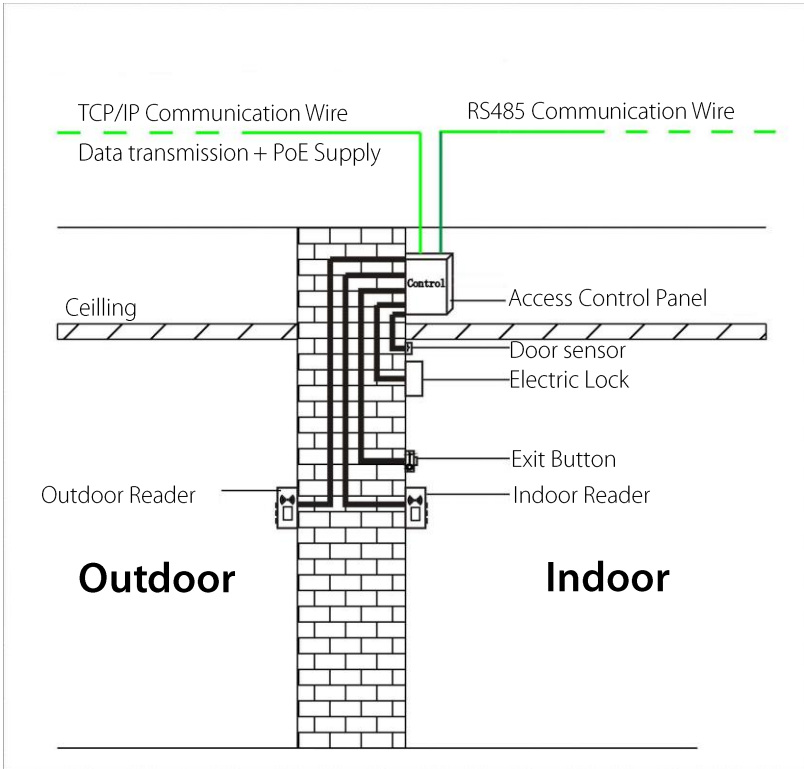

Access Control Panel Wire Installation

 **Notes:**

1. Before connection, make sure the power supply is disconnected. Any operation with power connected will cause severe damage to the equipment.
2. The access control wires must be separated according to heavy and light current; the control panel wires, electronic lock wires, and exit button wires must run through their respective conduits.

3.3 System Structure

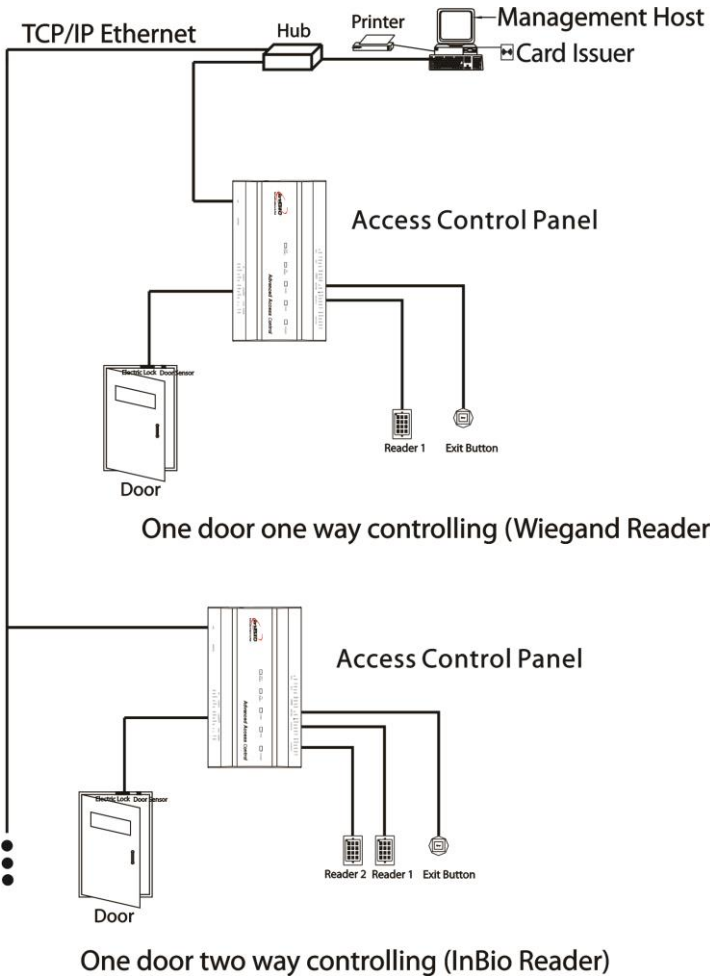

InBio-160 System Structure

The Access Control Management System consists of two parts: a management workstation (PC) and a control panel. They communicate via TCP/IP or RS485 networks. On a 485 bus, each management workstation can be connected with up

to 63 InBio control panels (preferably fewer than 32). The communication wires should be kept as far away from high-voltage wires as possible, and should be neither routed in parallel with nor bundled with power wires.

A management workstation is actually a PC connected to the network. By running the Access Control Management software installed on the PC, Access Control Management personnel can remotely perform various management functions, like adding/deleting a user, viewing event records, opening/closing doors, and monitoring the status of each door in real time.

3.4 Connection Terminals

InBio-160 Terminal Connection diagram:

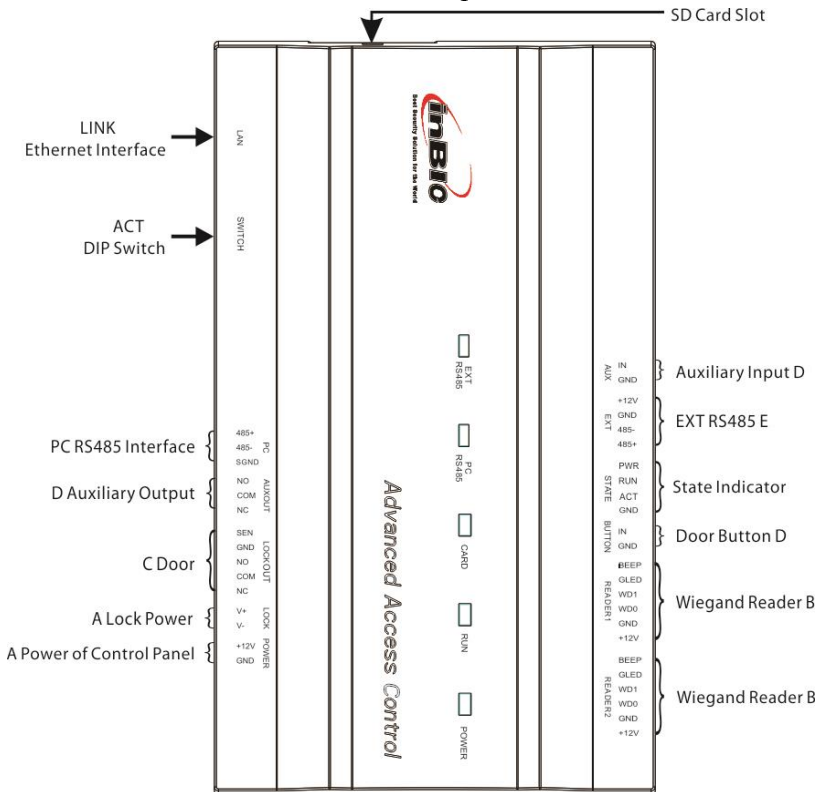

Descriptions of the terminals:

1. The auxiliary input may be connected to infrared body detectors etc (Used for signal detection of human body only, does not used for invasion burglar alarm application).
2. The auxiliary output may be connected to alarms, cameras, door bells, etc.
3. All the terminals mentioned above are set through relevant access control software.

Terminals on the InBio control panel:

No.	Functional Port	InBio-160 (One-door two-way)
1	Wiegand Card Reader Interface	2
2	Exit Button	1
3	Control Lock Relay	1
4	Door Sensor	1
5	Extension Input	1
6	Extension Output	1
7	InBio Reader	2
8	RS485 PC Communication	✓
9	RS485 Extension Communication	✓
10	TCP/IP	✓

3.5 Connection with External Accessories

1. Door sensor

A door sensor is used to detect the open/closed status of a door. With a door sensor switch, an access control panel can detect illegal opening of a door, and will trigger an alarm. Moreover, if a door is not closed within a specified period of time after it is opened, the door control panel will also prompt an alarm. It is recommended to select two-core wires over 0.22 mm². A door sensor may be omitted if it is

unnecessary to monitor online the open/closed status of a door, trigger an alarm when the door is not closed for a long time or there is illegal access, and use the interlock function.

2. Exit button

An exit button is a switch installed indoors to open a door. When you press the button, the door will be opened. An exit button is fixed at a height of about 1.4 meters above the ground. Ensure it is located in the right position without slant, and its connection is correct and secure (Cut off the exposed end of any unused wire and wrap it with insulating tape). Note to prevent the electromagnetic interference (such as light switches and computers). It is recommended to use two-core wires over 0.3mm² as the connection wire between an exit button and a control panel.

3. Auxiliary input

InBio-160 provides one auxiliary input interface, which is connected to infrared body detectors etc (Used for signal detection of human body only, does not used for invasion burglar alarm application). Auxiliary input is set through relevant access control software.

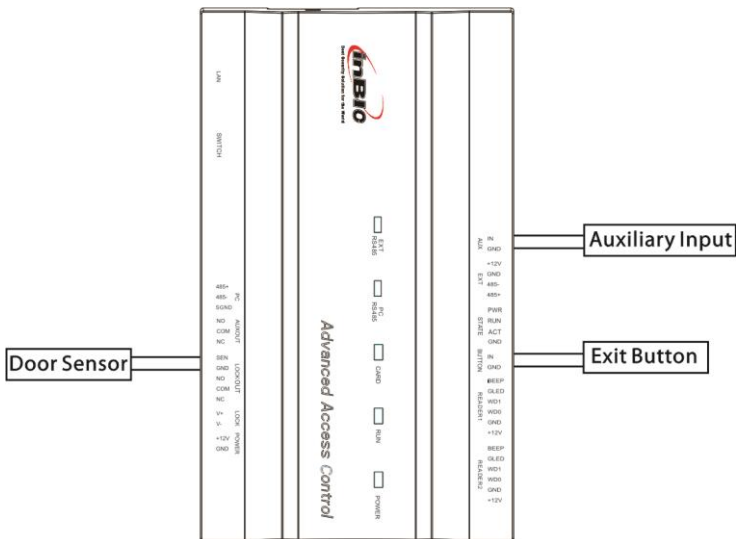

Connections between InBio-160 and external accessories

3.6 Connection with Readers

The control panel supports InBio biometric verification reader and Wiegand reader. The InBio reader executes all operations including storage, verification, etc. in the control panel. There is no need to re-register the fingerprints after changing the reader because of the existing biometric reader connection.

1. Connected with InBio readers

InBio-160 can connect two InBio readers in the one-door two-way mode.

Before connecting the InBio reader, use the software, DIP switch or keypad method to set the address (devices number) of the 485 reader firstly. For example, 1, 2 (the odd number is to enter reader, and the even number is to exit reader), where the 485 address is 1, 2, and the door number is 1.

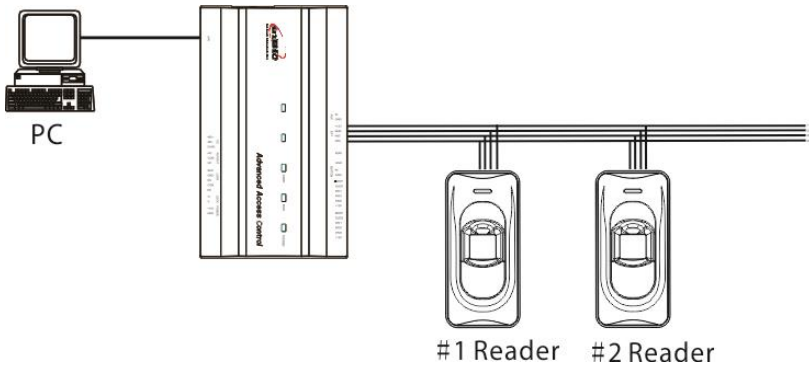

Connection between InBio-160 and InBio Readers

 **Note:** In InBio reader connection, if the reader shares the power with the control panel, it is recommended that the wire should be less than 100 meters. If you need to use a longer distance, please use a separate power supply.

2. Connected with Wiegand readers

InBio-160 can connect two Wiegand readers in the one-door two-way mode.

The Wiegand interfaces provided by the InBio series can be connected to

different types of readers. If your card reader does not use the voltage of DC 12V, an external power supply is needed. A reader should be installed at a height of about 1.4 meter above the ground and at a distance of 30-50mm away from a door frame.

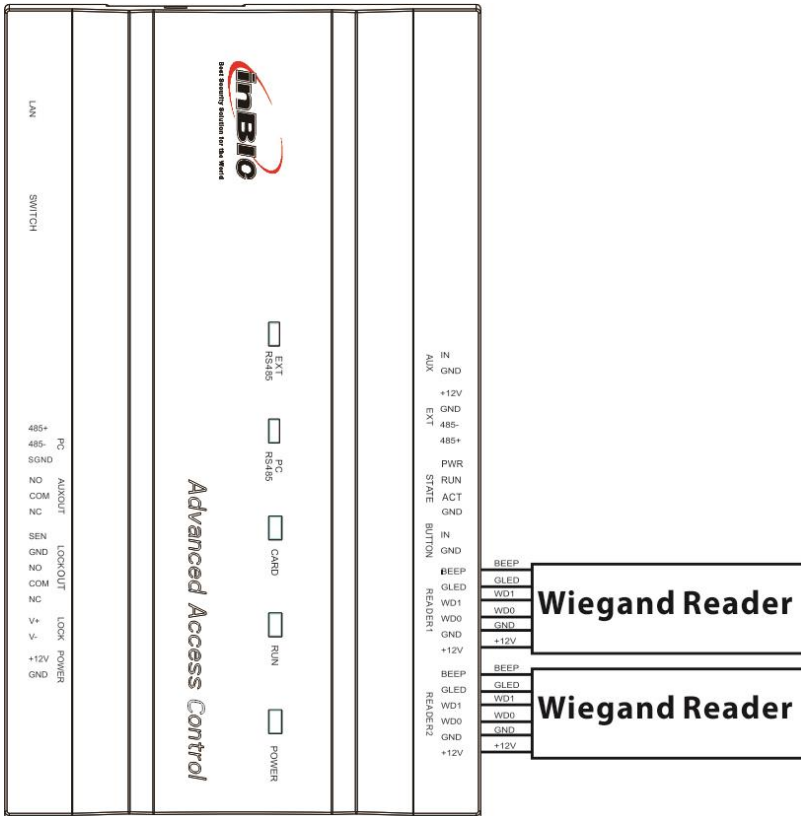

Connection between InBio-160 and Readers

3.7 Relay Output Connection

InBio-160 has two relays (by default, one used as a control lock and the other used as an auxiliary output).

The relays for auxiliary outputs may be connected to monitors, alarms, door bells etc. Auxiliary outputs are set through relevant access control software.

A lock relay can be connected in the dry and wet modes, while an auxiliary output relay cannot. The following illustrates a relay output connection in the example of door connection.

1) An access control panel provides multiple electronic lock outputs. The COM and NO terminals are applicable to the locks that are unlocked when power is connected and locked when power is disconnected (that is NO lock). The COM and NC terminals are applicable to the locks that are locked when power is connected and unlocked when power is disconnected (that is NC lock).

2) The control panel supports “dry mode” and “wet mode” by using the jumper.

Wet mode jumper setting: Short 2-3 and 4-5 terminals, and the device power supply will be used for the relay output.



Dry mode jumper setting: Short 1-2 and 3-4 terminals, and a separate lock power supply will be used for the relay output.



Note: The factory default jumper setting is set as wet mode.

3) To protect the access control system against the self-induced electromotive force generated by an electronic lock at the instant of switching off/on, it is necessary to connect a diode in parallel (please use the FR107 delivered with the system) with the electronic lock to release the self-induced electromotive force.

1. Wet mode: Connect NO lock and NC lock

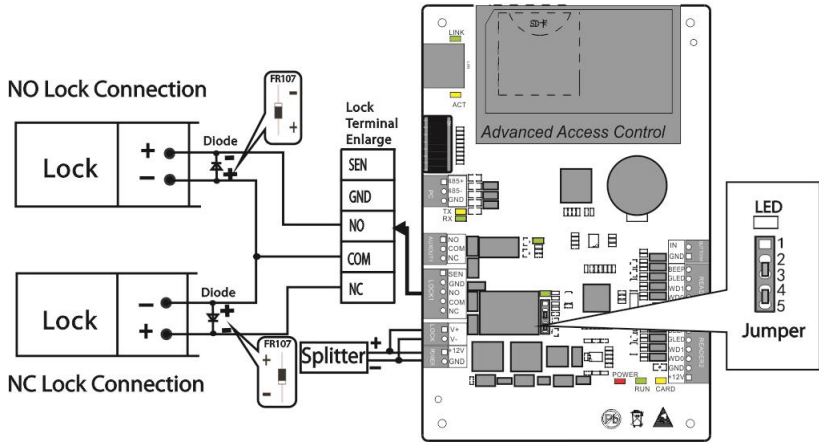

 **Note:** It is recommended to apply the wet mode in PoE power supply.

2. Dry Mode: Connect NO lock and NC lock

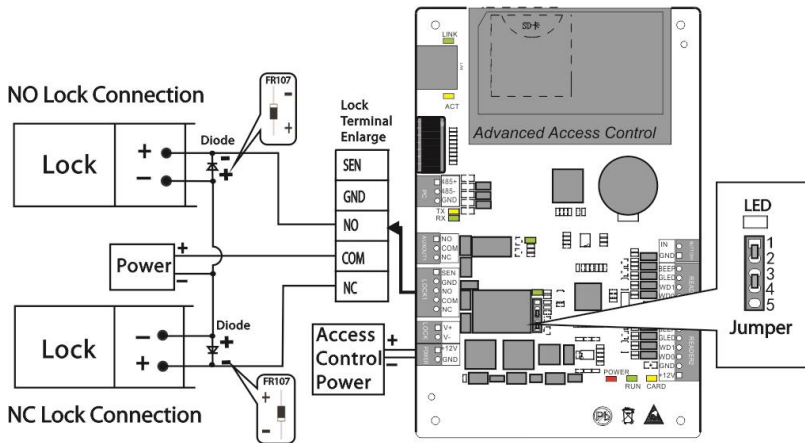

3.8 PoE Power Supply Structure

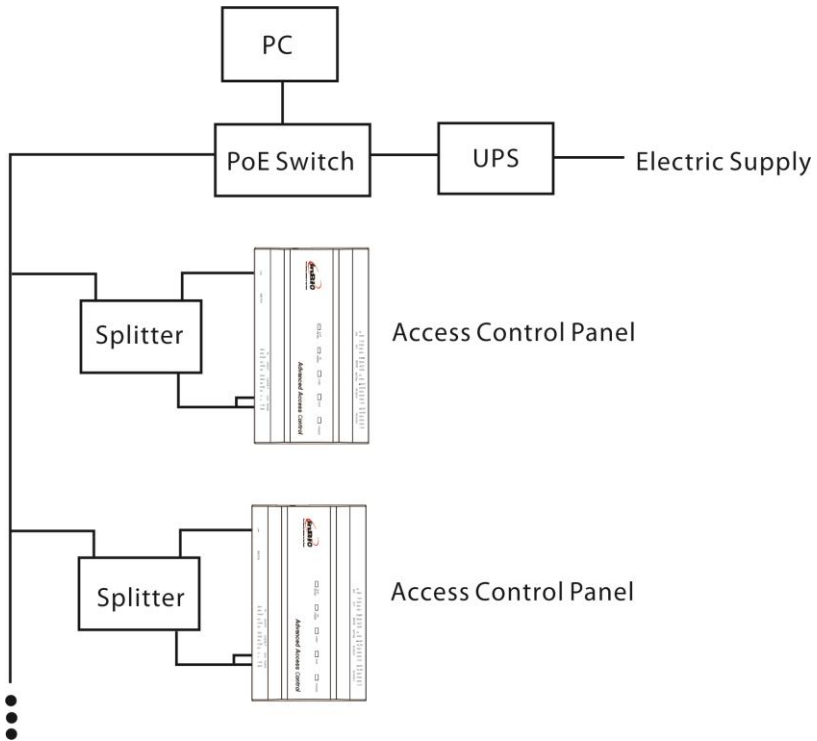

To prevent power failure of a control panel from making the whole system unable to work normally, the access control management system is usually required to have at least one UPS, and access control locks are powered externally to guarantee the access control management system can still work normally during a power failure.

4 System Networking

4.1 System Wiring and Wires Requirements

1. RS485 communication wires are made of internationally accepted shielded twisted pairs, which provide effective protection and shield of interference.

2. The power supply is 12V DC converted from 220V.

3. The Wiegand readers use 6-core communication shielded wires (RVVP 6×0.5mm) (usually there are 6, 8, and 10-core types available for users to select) to reduce interference during transmission.

4. As an electronic lock has a big current, it generates strong interference signal during an action. To reduce the effect of an electronic lock during an action on other elements, 4-core wires (RVV 4×0.75mm², two for a power supply and two for door sensor) are recommended.

5. For EXT485 communication, we suggest to using 4-conductor wire (RVVP 4×0.5mm)

6. Other control cables (like exit buttons) are all made of 2-core wires (RVV 2×0.5mm²).

7. Notes for wiring:

- Signal wires (like network cables and RS-485 wires) can neither run in parallel with nor share a conduit with large-power electric wires (like electronic lock wires and power cables). If parallel wiring is unavoidable for environmental reasons, the distance must be over 50cm.

- Try to avoid using any wire with a connector during wiring. When a connector is indispensable, it must be crimped or welded. No mechanical force can be applied to the joint or branch of conductors.

- In a building, distribution lines must be installed horizontally or vertically. They should be protected in conduit (like plastic or iron water pipes, to be selected according to the technical requirements of indoor distribution). Metal hoses are applicable to ceiling wiring, but must be secure and visually appealing.

- **Shielding measures and shielding connection:** If the electromagnetic interference in the wiring environment is found strong in the survey before construction, it is necessary to consider shielding protection for data cables when designing a construction scheme. Overall shielding protection is required if there is a large radioactive interference source or wiring has to be parallel with a large-current power supply on the construction site. Generally, shielding measures include: Keeping a maximum distance from any interference source, and using metal wiring troughs or galvanized metal water pipes to ensure reliable grounding of the connection between the shielding layers of data cables and the metal troughs or pipes. Note that a shielding enclosure can have a shielding effect only when it is grounded reliably.

- **Ground wire connection method:** Reliable large-diameter ground wires in compliance with applicable national standards are needed on the wiring site, and should be connected in a tree form to avoid DC loop. These ground wires must be kept far away from lightning fields. No lightning conductor can serve as a ground wire, and ensure there is no lightning current through any ground wire when there is lightning. Metal wiring troughs and pipes must be connected continuously and reliably, and linked to ground wires through large-diameter wires. The impedance of this section of wire cannot exceed 2ohm. The shielding layer also must be connected reliably, and grounded at one end to guarantee uniform current direction. The ground wire of the shielding layer must be connected through a larger wire (not smaller than 2.5mm²).

4.2 TCP/IP Network Communication

The Ethernet 10/100Base-T Crossover Cable, a type of crossover network cable, is mainly used for cascade hubs and switches, or used to connect two Ethernet end-points directly (without a hub). Both 10Base-T and 100Base-T are supported.

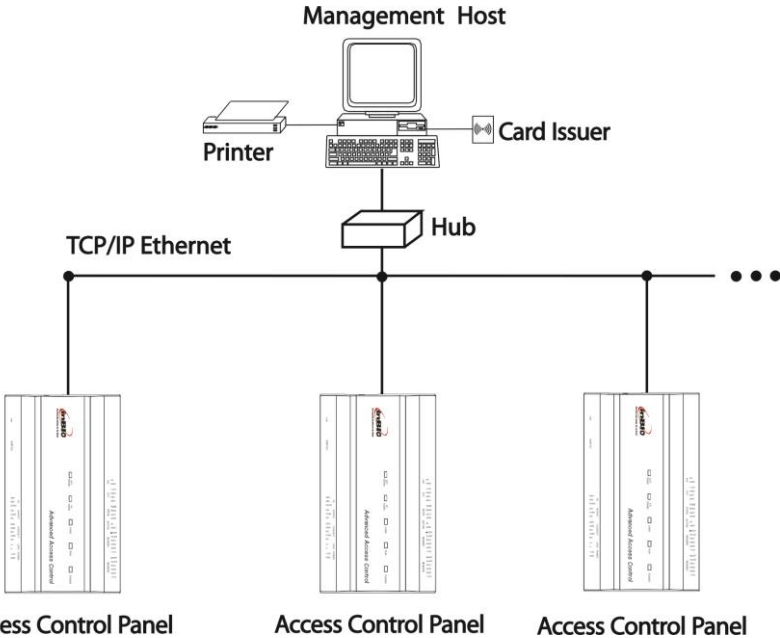

TCP/IP Communication System Networking

4.3 RS485 Network Communication

1. RS485 communication wires are made of internationally accepted RWP wires (shielded twisted pairs), which prove effective to prevent and shield interference. RS485 communication wires should be connected by means of bus cascade instead of in a star form, to achieve a better shielding effect by reducing signal reflection during communications.

2. A single 485 bus can be connected with 63 access control operator panels at most, but preferably should be connected with less than 32.

3. In InBio reader connection, if the reader shares the power with the control panel, it is recommended that the wire **should be less than 100 meters in length**. If you need to use in a longer length, please use a separate power supply.

4. To eliminate signal attenuation in communication cables and suppress

interference, if the bus is longer than 300 meters, one 120ohm resistance is usually inserted between the first and last access control operator panels on the RS485 bus.

5. For this access control operator panel, putting place 8 of the DIP switch to the **ON** position is equivalent to parallel connection of one 120ohm resistance between the 485+ and 485- lines.

As shown in the figure below, put number 8 of the DIP switches of the first and

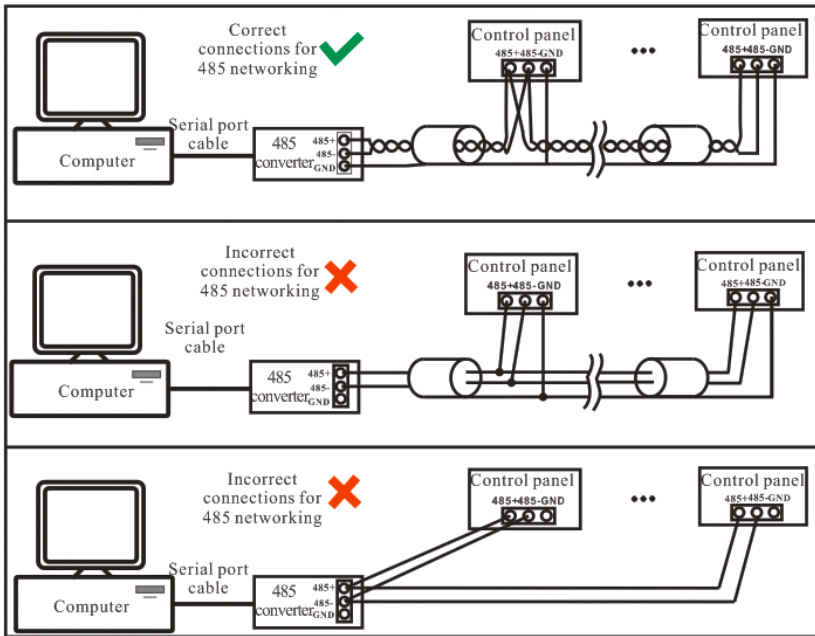

RS485 Communication System Networking

4.4 DIP Switch Settings

● 485 Address Setting

Number 1-6 of the DIP switch are reserved to set the device number for RS485

communication. The code is binary, and the lower places are in the front. When the switch is set to ON position, it indicates 1 (on); when the switch is set downwards, it indicates 0 (off).

For example, to set a device number 39=1+2+4+32, which corresponds to the binary code 111001, put number 1, 2, 3, and 6 to ON position, as illustrated below.

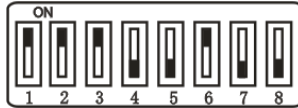

485 Address Setting Table:

Address	Place	Switch Setting					
		1	2	3	4	5	6
Address No.		1	2	4	8	16	32
01		ON	OFF	OFF	OFF	OFF	OFF
02		OFF	ON	OFF	OFF	OFF	OFF
03		ON	ON	OFF	OFF	OFF	OFF
04		OFF	OFF	ON	OFF	OFF	OFF
05		ON	OFF	ON	OFF	OFF	OFF
06		OFF	ON	ON	OFF	OFF	OFF
07		ON	ON	ON	OFF	OFF	OFF
08		OFF	OFF	OFF	ON	OFF	OFF
09		ON	OFF	OFF	ON	OFF	OFF
10		OFF	ON	OFF	ON	OFF	OFF
11		ON	ON	OFF	ON	OFF	OFF
12		OFF	OFF	ON	ON	OFF	OFF
13		ON	OFF	ON	ON	OFF	OFF
14		OFF	ON	ON	ON	OFF	OFF
15		ON	ON	ON	ON	OFF	OFF
16		OFF	OFF	OFF	OFF	ON	OFF
17		ON	OFF	OFF	OFF	ON	OFF

18	OFF	ON	OFF	OFF	ON	OFF
19	ON	ON	OFF	OFF	ON	OFF
20	OFF	OFF	ON	OFF	ON	OFF
21	ON	OFF	ON	OFF	ON	OFF
22	OFF	ON	ON	OFF	ON	OFF
23	ON	ON	ON	OFF	ON	OFF
24	OFF	OFF	OFF	ON	ON	OFF
25	ON	OFF	OFF	ON	ON	OFF
26	OFF	ON	OFF	ON	ON	OFF
27	ON	ON	OFF	ON	ON	OFF
28	OFF	OFF	ON	ON	ON	OFF
29	ON	OFF	ON	ON	ON	OFF
30	OFF	ON	ON	ON	ON	OFF
31	ON	ON	ON	ON	ON	OFF
32	OFF	OFF	OFF	OFF	OFF	ON
33	ON	OFF	OFF	OFF	OFF	ON
34	OFF	ON	OFF	OFF	OFF	ON
35	ON	ON	OFF	OFF	OFF	ON
36	OFF	OFF	ON	OFF	OFF	ON
37	ON	OFF	ON	OFF	OFF	ON
38	OFF	ON	ON	OFF	OFF	ON
39	ON	ON	ON	OFF	OFF	ON
40	OFF	OFF	OFF	ON	OFF	ON
41	ON	OFF	OFF	ON	OFF	ON
42	OFF	ON	OFF	ON	OFF	ON
43	ON	ON	OFF	ON	OFF	ON
44	OFF	OFF	ON	ON	OFF	ON
45	ON	OFF	ON	ON	OFF	ON
46	OFF	ON	ON	ON	OFF	ON

47	ON	ON	ON	ON	OFF	ON
48	OFF	OFF	OFF	OFF	ON	ON
49	ON	OFF	OFF	OFF	ON	ON
50	OFF	ON	OFF	OFF	ON	ON
51	ON	ON	OFF	OFF	ON	ON
52	OFF	OFF	ON	OFF	ON	ON
53	ON	OFF	ON	OFF	ON	ON
54	OFF	ON	ON	OFF	ON	ON
55	ON	ON	ON	OFF	ON	ON
56	OFF	OFF	OFF	ON	ON	ON
57	ON	OFF	OFF	ON	ON	ON
58	OFF	ON	OFF	ON	ON	ON
59	ON	ON	OFF	ON	ON	ON
60	OFF	OFF	ON	ON	ON	ON
61	ON	OFF	ON	ON	ON	ON
62	OFF	ON	ON	ON	ON	ON
63	ON	ON	ON	ON	ON	ON

● Restoring Factory Setting

The silk-screened 7 (number 7) of the DIP switch is the switch for restoring system settings. The switch is set to OFF by default. When it is moved upwards and downwards for three times within 10 seconds and finally returned to OFF position, the factory settings will be restored after the access control panel is restarted.

● Terminal Resistance Setting

Number 8 is for setting the RS485 termination resistance. Putting the switch to ON position is equivalent to parallel connection of a 120ohm termination resistance between 485+ and 485-.

