

# TS1000 Series Vertical Tripod Turnstile User Manual

---

Version: 2.0

Date: March, 2015

**TS1000:** Tripod Turnstile

**TS1011:** Tripod Turnstile with Controller and RFID Reader

**TS1022:** Tripod Turnstile with Controller and Fingerprint Reader with RFID function.

Please read this document carefully before installation and using the device.

## 1. Technical Specifications

Input Voltage	AC 100V ~ 240V, 50Hz ~ 60Hz	Max. Tolerance of Arms	Center: 80 kg End: 40 kg
Rated Power	60 W	Ingress Protection Degree	IP54
Operating Environment	Indoor and Outdoor (shelter)	Arm Length (mm)	500
Operating Temperature	-28°C ~ 60°C	Net Weight	34kg
Operating Humidity	5% ~ 85%	Gross Weight	40kg
Flow Rate	25~48 passages / minute	Dimension(mm) Figure 1	L = 520, W = 280, H = 980
Input Control Signal	Dry contact	Package Size (mm)	L = 600, W = 380, H = 1080

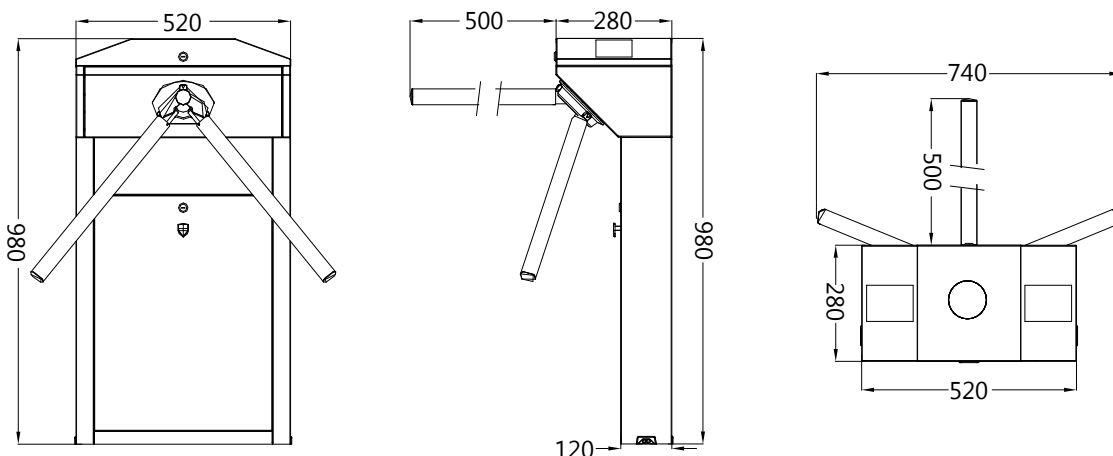
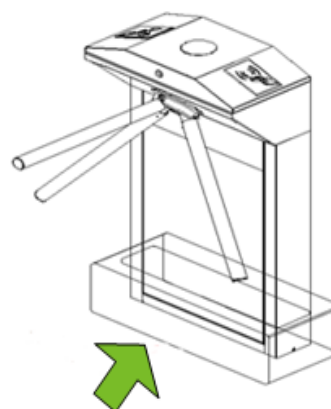

Figure 1

## 2. Unpacking and Testing the Tripod Turnstile

### 2.1 Unpacking

The vertical type tripod turnstile is top heavy and unsteady, do not remove the foam at the bottom before installation, as shown in figure 2-1.



Do not remove the foam lining at the bottom before installation.

Figure 2-1

## 2.2 Arm Installation Method

### Installation procedure

1. Open the glue and apply in the square opening of the arms as well as the one countersunk screw, as shown in figure 2-2. (This is to prevent screws from getting loose due to vibration after being used for a long time.)
2. Insert the arms to the connection points, and use the Hex key to fasten the one screw on each arm, as shown in figure 2-3.

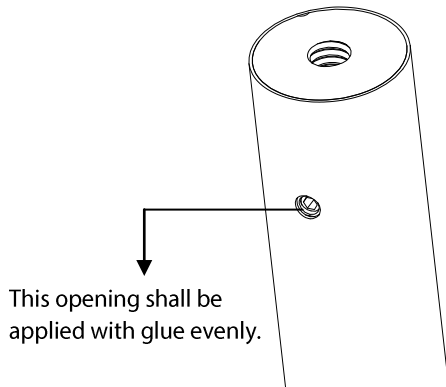

Figure 2-2

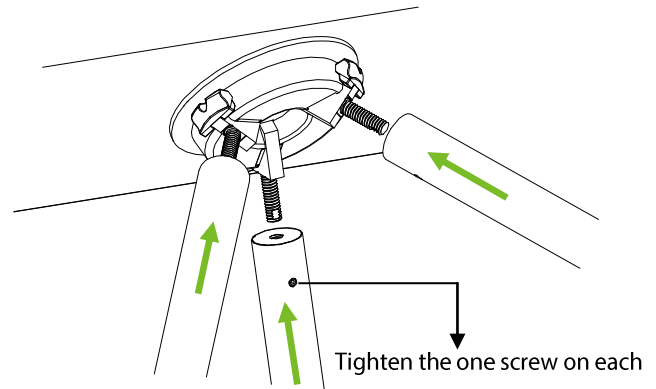

Figure 2-3

## 2.3 Power-on Test Before the Installation of Device

1. Please make sure that the power requirements are strictly met to avoid permanent damage to the unit. Input voltage 100V ~ 240V is self-adaptive.

**Note:** The tripod turnstile must be connected to the ground (earth).

2. Power on and wait 30s for the tripod turnstile to finish the self-check program.
3. Lift the arms manually, as shown in figure 2-5.
4. Check whether the tripod turnstile and the LED indicators work properly.

If there is any problem, please contact the supplier.

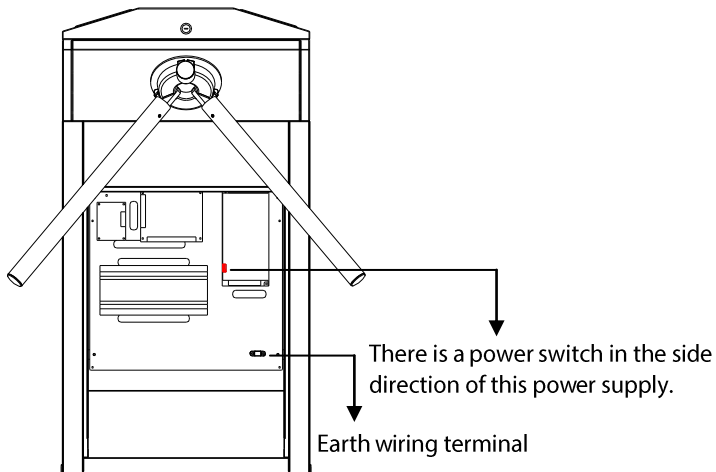

Figure 2-4

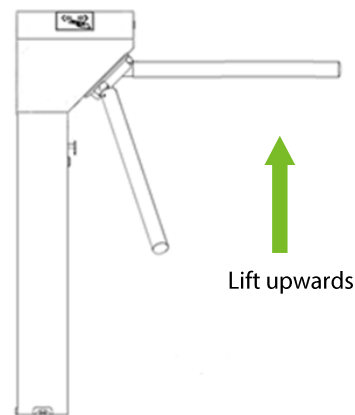

Figure 2-5

## 3. Equipment Installation

### 3.1 Installation Conditions

The equipment must be installed on concrete ground, ensuring that expansion bolts can be secured firmly.

You are suggested to install an assistant framework or fence to form a passageway, as shown in figure 3-1.

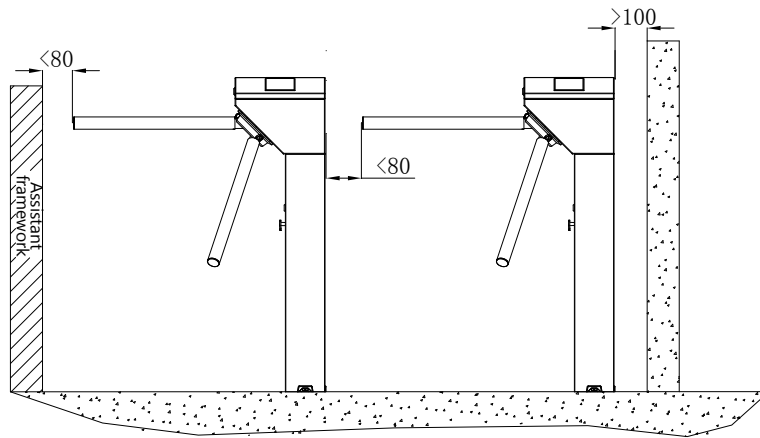

Figure 3-1

**Notes:**

1. When installing the tripod turnstile against the wall, please reserve at least 100 mm space in order to open the cover for adjustment and maintenance.
2. The space at the end of the arm shall not be greater than 80 mm (see Figure 3-1).
3. Setting a warning line for card swiping (see Figure 3-2). A warning line is suggested to prompt users to swipe cards in a distance, which would greatly reduce the probability of equipment failure caused by improper operations.

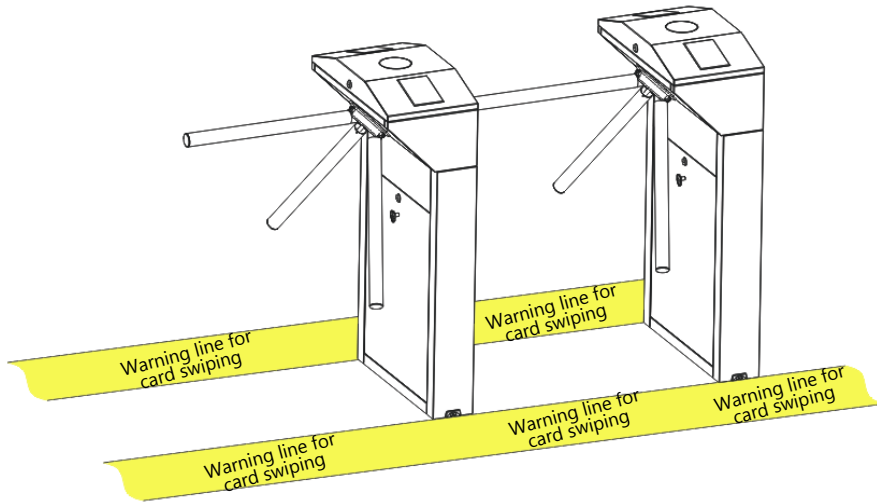

Figure 3-2

**3.2 Cabling**

There are inlets in the bottom plate for cabling, as shown in figure 3-3, the unit is millimeter. Power supply and communication wire should go through the inlet. Cable protection covers are suggested to use if it is surface mounted.

**Warning:** The tripod turnstile must be connected to the Ground (earth), there is wiring interface near the power switch.

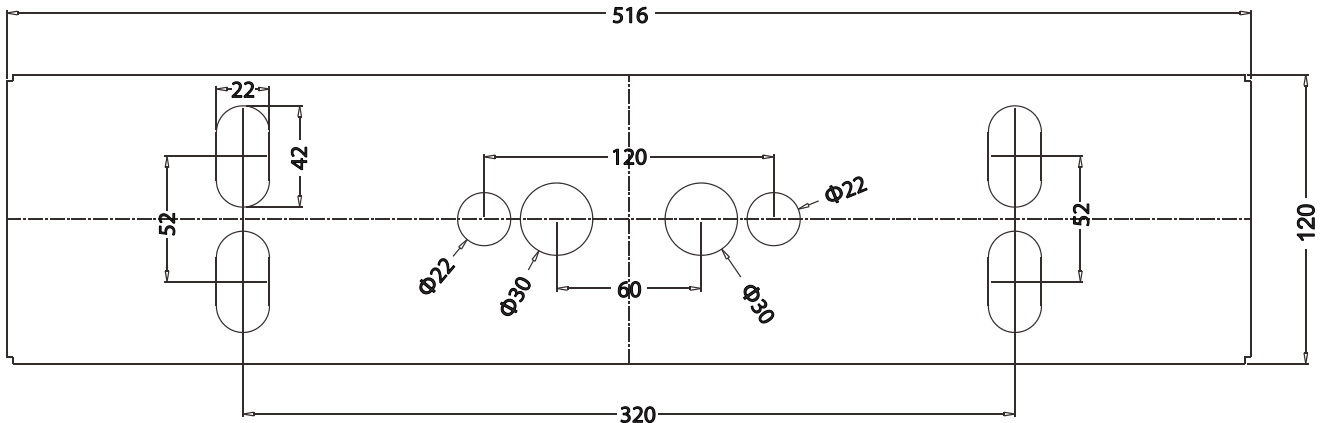

Figure 3-3

### 3.3 Installation

1. Drilling holes.

Drill holes based on the locations of the holes shown in figure 3-3.

2. Fix the mounting plate to its original position.

Placing the mounting plate properly and apply screw securing glue on the surface and the threads of the expansion bolts, install four expansion bolts to secure the mounting plate, and use a horizontal ruler to test the levelness of the mounting plate. If the mounting plate is not level, adjust it by the gaskets provided. Note that all the four expansion bolts must be installed properly, as shown in figure 3-4.

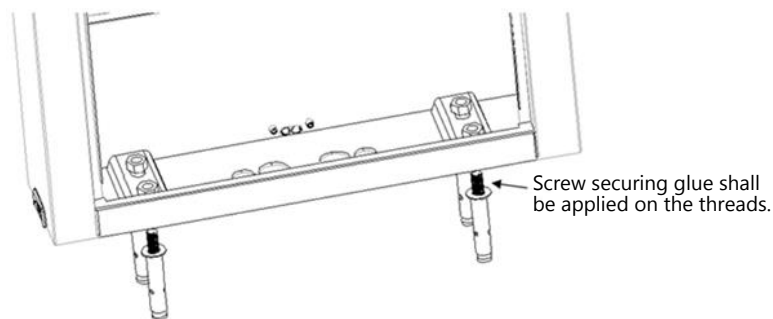

Figure 3-4

3. Put the turnstile on the mounting plate and tighten the screws. Apply screw securing glue before using and putting gaskets on the screws to adjust the direction of the turnstile. If the tripod turnstile is not level, you can place gaskets to adjust, as shown in figure 3-5.

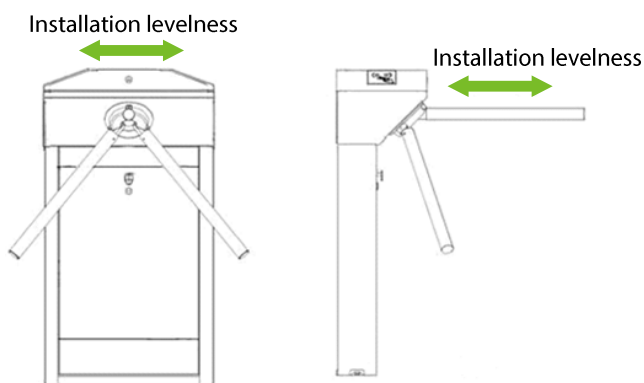

Figure 3-5

## 4. Cable Diagram

### 4.1 Function Description of the Turnstile Control Board

If you are using TS1011 or TS1022, all the connections between access control and turnstile control boards are done in factory. Just plug in communication cable to access controller and do the setting.

If you are using TS1000, you need to connect access control system to the main board, please check the content in this chapter carefully.

**Warning:** The third party access control system lock relay trigger time should be 1 second or less than 1 second.

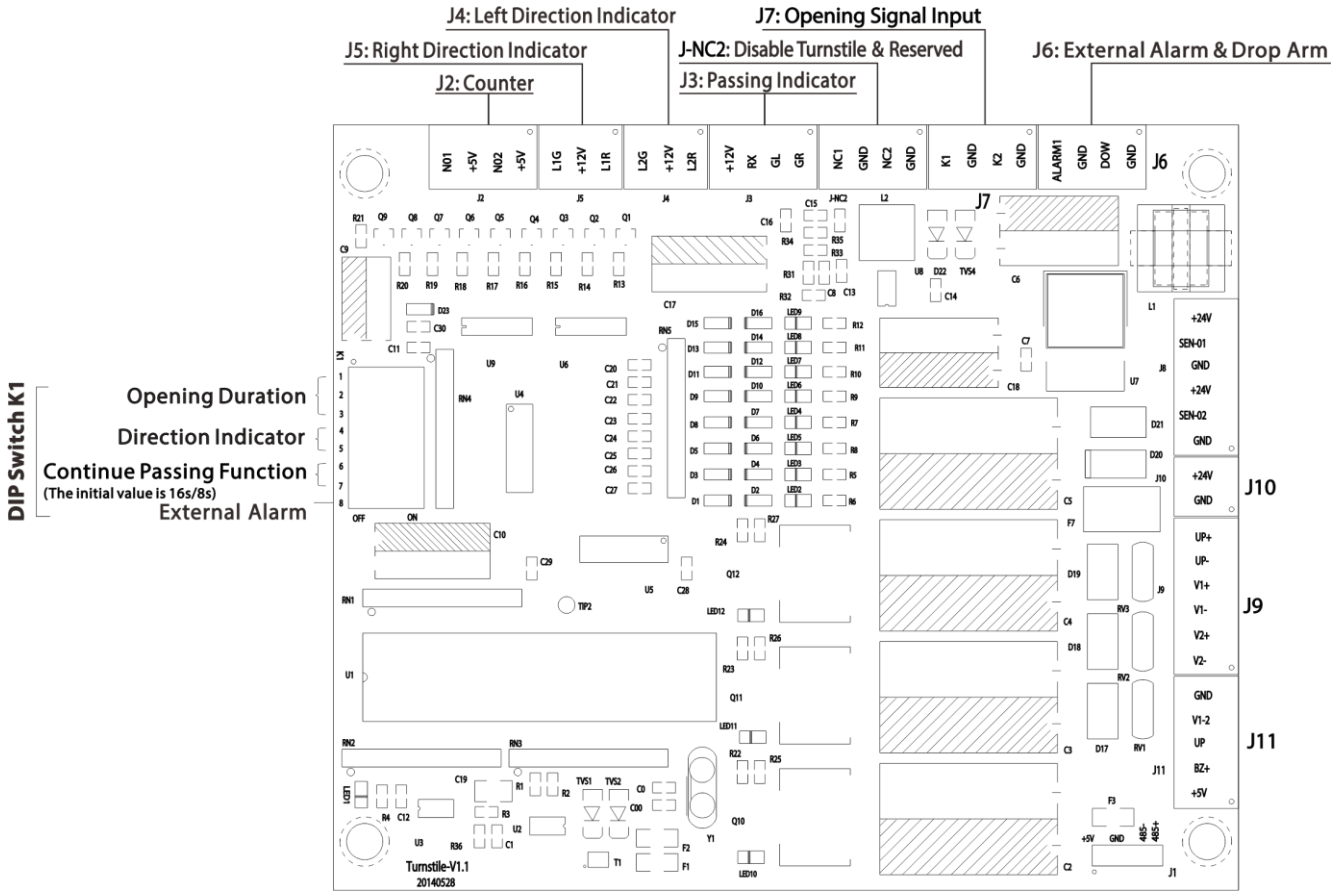

Figure 4-1

#### Descriptions:

**J2 Counter:** To connect a LED screen and display the number of people passed that is generated by the push of tripod arms, each completed push means pass one time.

**J5 (Right) & J4 (Left) Indicator:** To connect a LED screen and indicate whether this passage is allowed to pass.

**J3 Indicator (top):** To connect a LED screen and indicate if user verification is successful and whether it is able to pass.

**J-NC2 Disabled Turnstile:** Short circuit NC1 and GND, the turnstile is disabled, that is to say, the turnstile is locked by force.

**J7 Opening Signal Input:** To receive relay signal and open the turnstile. Short circuit K1 and GND, left passing is allowed; short circuit K2 and GND, right passing is allowed.

**J6 External Alarm:** Short circuit ALARM1 and GND, and the turnstile is disabled (locked) and the alarm is ringing in case there are emergencies.

**J6 Drop Arm:** Short circuit DOW and GND, the arm is dropped down by force in case there are fires or other emergencies.

### 4.2 Connection Diagram of the Standalone Access Control Device

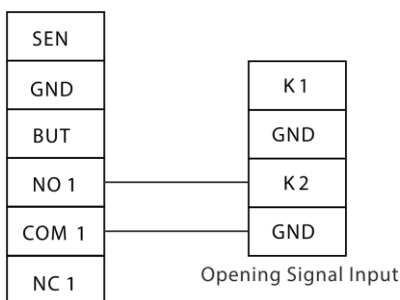

**Note:** The lock driving duration of standalone access control device needs to be set to 1s or 0s, and the door sensor needs to be set to "None".

Standalone Access Control Device

Figure 4-2

### 4.3 DIP K1 Switch Configuration

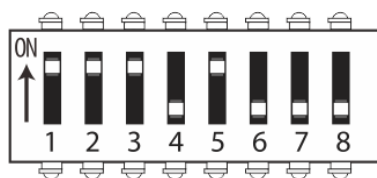

Figure 4-3

Pin	1	2	3	4	5	6	7	8
Function Setting	Opening Duration			Direction Indicator		Continue Passing Function		Alarm
Default	1	1	1	0	1	0	0	0

#### 4.3.1 Setting the Turnstile Opening Duration

Opening duration refers to the period of time from opening to closing once the turnstile receives an open signal. In the DIP switch, number 1, 2, and 3 are used for duration setting. It can be set to different values from 5s to 60s according to the following chart.

Bit Setting	Duration	Bit Setting	Duration
111	5s	011	30s
110	10s	010	40s
101	15s	001	50s
100	20s	000	60s

**Note:** The turnstile opening duration is set to 5s by default.

#### 4.3.2 Direction Indicator

It is to indicate whether the passage allows people to pass. The green arrow means passing is allowed while the red "X" means passing is prohibited. The indicator status can be set through number 4 and 5 in the DIP switch. The description of the bit settings are as follows:

**11** = One-way traffic, left passing is allowed.

**10** = One-way traffic, right passing is allowed.

**01** = Passing is allowed in both directions.

#### 4.3.3 Continue Passing Function

With the Continue Passing function, the turnstile could remember at most 20 swipes of one card at one time and allows up to 20 people to pass so they don't have to swipe card each time, this function can be enabled or disabled through number 6 in the DIP switch. The description of the bit settings are as follows:

In the DIP switch, number 6 is used to enabled or disabled the **Continue Passing Function**, number 7 is used to set the initial value of **Continue Passing Function**.

number 6	number 7	Function	Opening Duration
0	disabled	Disabled <b>Continue Passing Function</b>	Please consult <a href="#">4.3.1 Setting the Turnstile Opening Duration</a>
1	1	Enabled <b>Continue Passing Function</b>	The initial value is 16s, and the <b>Opening Duration</b> = 16 + (N-1) * 6
	0		The initial value is 8s, and the <b>Opening Duration</b> = 8+ (N-1) * 6

#### 4.3.4 Alarm Function (Optional)

In the DIP K1 switch, number 8 is used to enabled or disabled the **Alarm Function**.

1 = enabled

0 = disabled

**Note:** Please set to 0 when working normally, that is to say that **Alarm Function** is disabled.

## 5. Equipment Precautions and Maintenance

### 5.1 Precaution

1. It is recommended to purchase optional accessories to use in outdoor environment.
  - (1) It shall install optional cooling fans for the equipment if the working temperature is often above 50 °C.
  - (2) It is equivalent to IP54 waterproof under proper installation. However, it cannot work in the region that may suffer typhoon.
  - (3) If the temperature is -30°C, a heating plate is suggested to install. It might need multiple times to power on while getting hot automatically through the self-check program.
  - (4) The service life of this equipment may be shortened if it works outdoors in coastal areas or a region prone to acid rain.
2. If the power and signal cables are connected properly, this equipment can be immersed in water of 250 mm deep, but it must not be powered on for operating when it is immersed in water.
3. It is highly recommended that a card swiping warning line to set for prompting passers-by to swipe cards properly and a reasonable passage width shall be set to prevent passers-by from squeezing in illegally.
4. It is recommended that a warning sign is placed at a conspicuous position, and prompt: **"Please swipe your card outside the warning line and pass in order. Thank you!"**

#### The maximum tolerance of the tripod turnstile's arms

Please note that the maximum stress tolerance at the center of the arm is 80kg and at the ends of the arm is 40kg (See figure 5-1).When the impact force on the tripod turnstile reaches the designed limit, the arms break down first to ensure that the whole equipment is not damaged and the passer-by is not injured.

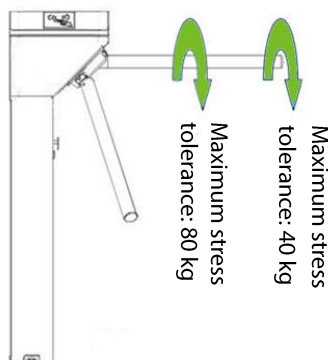

Figure 5-1

#### In case of emergencies

This equipment is designed to drop down arms automatically if there is power failure thus make the passage being open to the public. And there is interface in the turnstile main board to connect an emergency switch (J6 Drop Arm) which would make the tripod turnstile keep open in case of emergencies. Note after power restoration, wait for more than 6s and then lift the arms manually.

### 5.2 Maintenance

#### Forming maintenance consciousness

The tripod turnstile needs to be maintained regularly and repaired once it is damaged. It is recommended that warning signs being placed at conspicuous positions for prompting passers-by to pass in a proper way and in good order. Reasonable maintenance consciousness helps to guarantee long-term usage of the tripod turnstile.

#### Regular maintenance

Cleaning and protection liquid dedicated for stainless steel are recommended to wipe the outer shell of the equipment regularly. The tripod turnstile used outdoors or in an environment with lots of dust must be maintained once a year at least, for example, clean up the dust and add appropriate lubricating oil to Trilobed Wheel. Note regular maintenance should be performed after power off the equipment.

The Adjustable Tension Spring is used to adjust the tripod turnstile's elasticity and return speed. You can rotate it in clockwise direction to enhance and in anticlockwise direction to weaken the elasticity and return speed of the tripod turnstile. See figure 5-2.

Figure 5-3 shows the mechanical and electrical structure of this equipment.



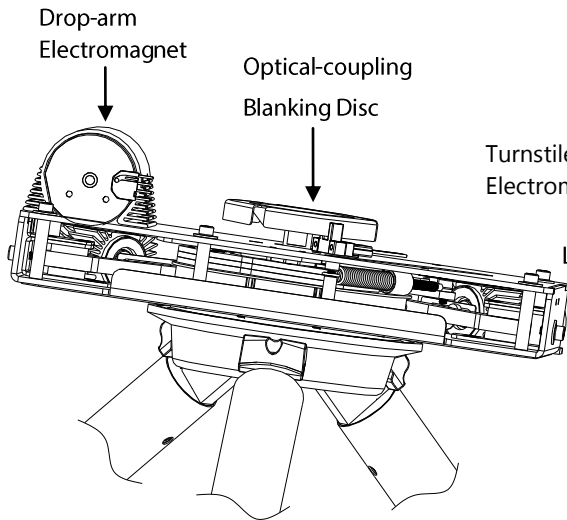

Figure 5-2

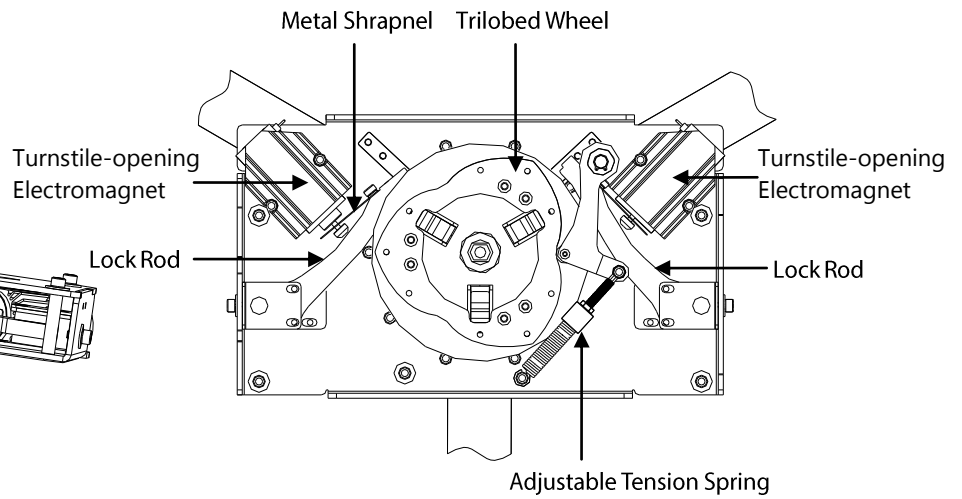

Figure 5-3

## 5. Troubleshooting

Symptom	Troubleshooting
The indicator is not lighted when the equipment is powered on.	It may be caused by the power supply or circuit. Check whether the connection cable and power cable between are damaged, or the wiring is loose.
The arms of the tripod turnstile cannot be lifted manually after the equipment is powered on.	It may be caused by the problem of relative components or drop-arm electromagnet. 1. Check whether the stop base and turn plate withstands each other, as shown in figure 6-1. 2. Check whether the drop-arm electromagnet is operating. Remove the upper cover of the framework, use a hex key to remove the cover of the control module (as shown in figure 6-2), and check the work status of the electromagnet, as shown in figure 6-3.
The tripod turnstile does not open after authentication.	It may be caused by lack of permission or a circuit problem. 1. Check whether the user has the permission to open the turnstile. 2. Use a multimeter to check whether the NO and COM ports of the access control system has a relay signal output. 3. Short-circuit the ports "K1, GND" and "K2, GND", if the turnstile is successfully opened, it would be the problem of controller. In this case, please refer to <a href="#">Attachment 2 Connection Diagram of Mainboard and Access Control Panel</a> to check the cable connection of the controller.
The passing is not smooth after the turnstile is opened, it encounters resistance when pushing the arms, and the arms cannot return to the home position after they rotate.	It is caused by the Adjustable Tension Spring. Adjust the Adjustable Tension Spring, as shown in figure 5-2.
The arms drop during the use.	It may be caused by the problem of relative components or drop-arm electromagnet. 1. Check whether there is any gap at the position shown in figure 6-1. 2. Check whether the drop-arm electromagnet is totally closed. If not, power off the equipment and power on it again 2 minutes later.
The turnstile allows people continue passing one-way side during the use.	1. Check the Turnstile-opening Electromagnet 2. Check whether the Turnstile-opening electromagnet is operating. Remove the upper cover of the framework, use a hex key to remove the cover of the control module (as shown in figure 6-2), and check whether the Turnstile-opening electromagnet is stuck or the Metal Shrapnel is broken, as shown in figure 6-3.

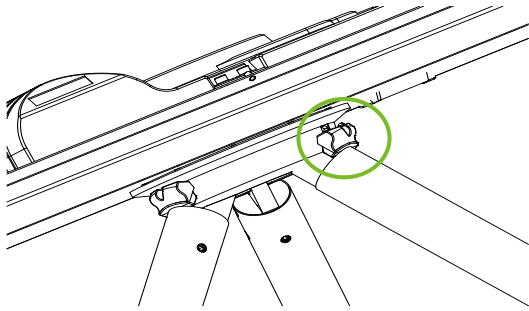

Figure 6-1

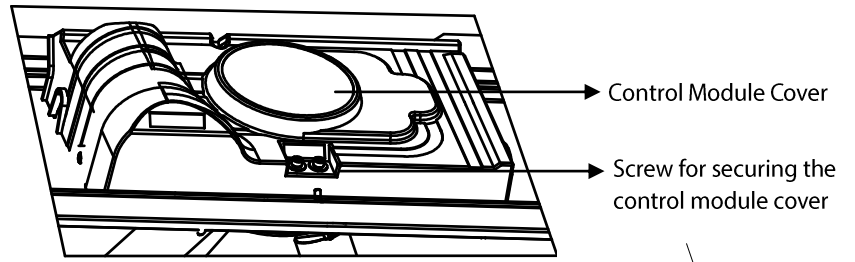

Figure 6-2

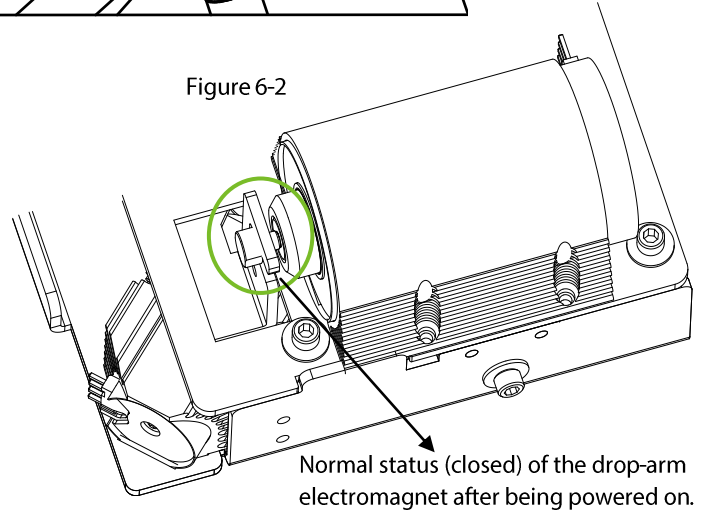
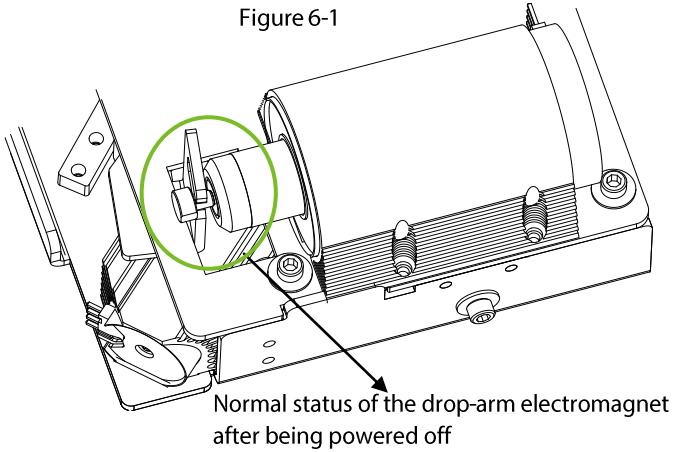

Figure 6-3

## Attachment 1 Default Factory Settings

No.	Function	Default
1	Lock Driving Duration	5s
2	Door Sensor	None
3	Verification Interval	1s
4	Controller Communication	TCP/IP: 192.168.1.201
5	Turnstile Opening Duration	5s
6	Passing Direction Indicator	Passing is allowed in both directions
7	Continue Passing Function	Disabled
8	Alarm Function	Disabled

**Note: The Lock Driving Duration is default 5 seconds, please set to 1 second.**

# Attachment 2 Connection Diagram of Mainboard and Access Control Panel

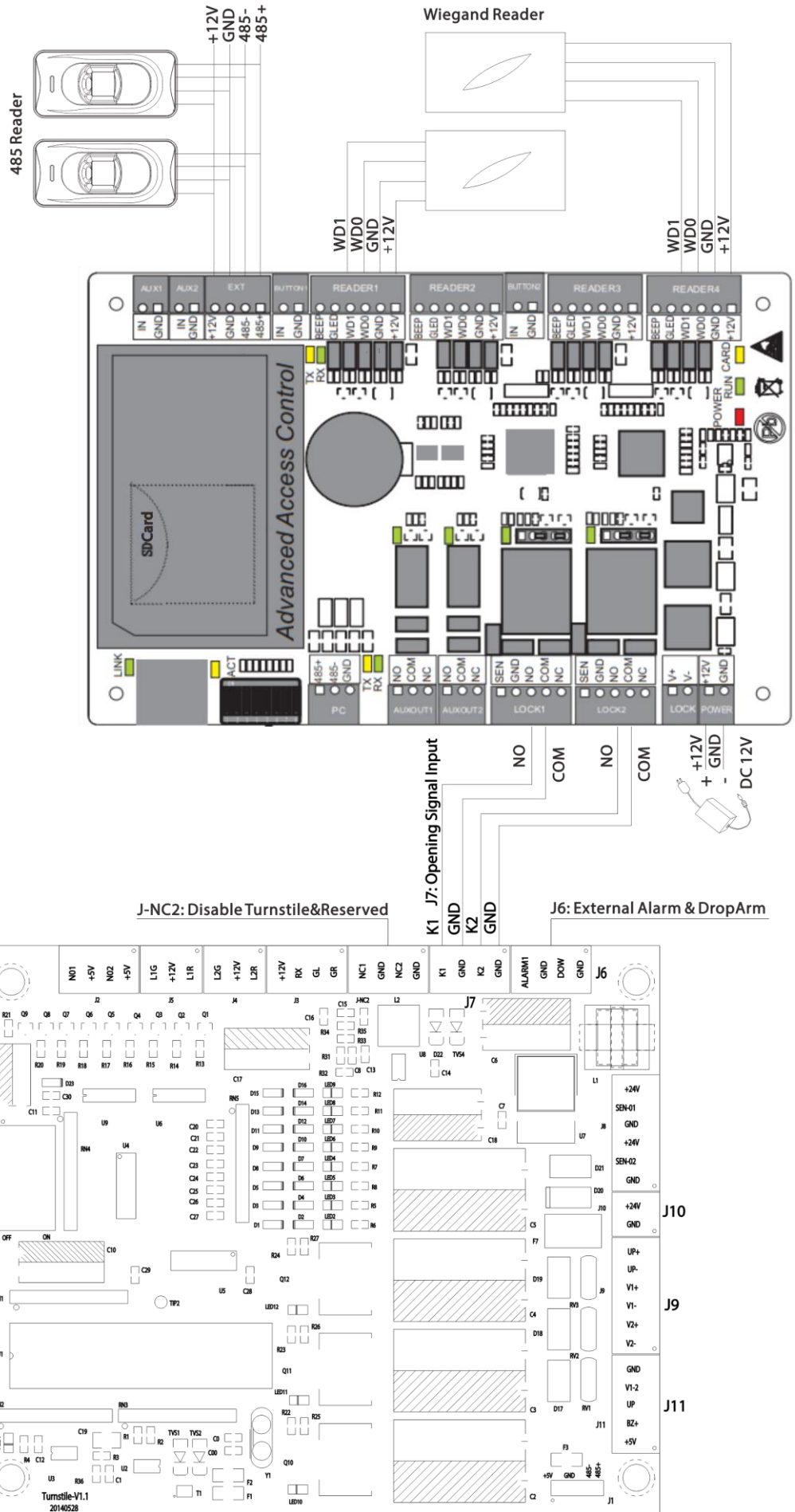

# Attachment 3 Connection Diagram of Mainboard and Secondary board

The connection of Mainboard and Secondary Board.

Mainboard	Secondary board
J10	J1
J9	J2
J11	J3

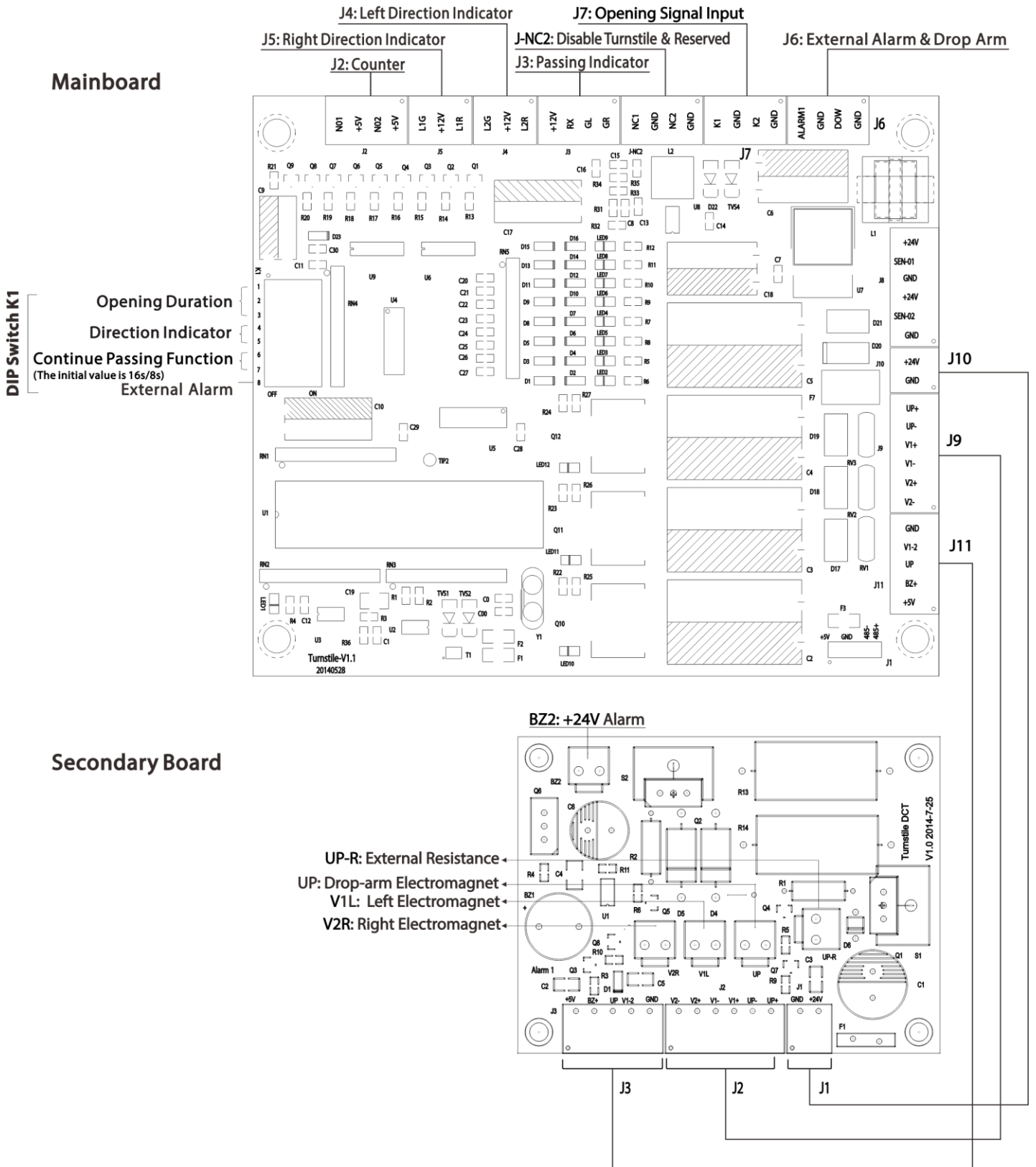

**Warning:** This is a class A product. In a domestic environment this product may cause radio interference in which case the user may be required to take adequate measures.