

# USER MANUAL

## ProID Series Water Resistant RFID Access Control Reader

---

Applicable Models: ProID Series

Version: 1.2

Date: August 2023

English

## Copyright © 2023 ZKTECO CO., LTD. All rights reserved.

Without the prior written consent of ZKTeco, no terminalion of this manual can be copied or forwarded in any way or form. All parts of this manual belong to ZKTeco and its subsidiaries (hereinafter the "Company" or "ZKTeco").

### Trademark

**ZKTeco** is a registered trademark of ZKTeco. Other trademarks involved in this manual are owned by their respective owners.

### Disclaimer

This manual contains information on the operation and maintenance of the ZKTeco equipment. The copyright in all the documents, drawings, etc. in relation to the ZKTeco supplied equipment vests in and is the property of ZKTeco. The contents hereof should not be used or shared by the receiver with any third party without the express written permission of ZKTeco.

The contents of this manual must be read as a whole before starting the operation and maintenance of the supplied equipment. If any of the content(s) of the manual seems unclear or incomplete, please contact ZKTeco before starting the operation and maintenance of the said equipment.

It is an essential pre-requisite for the satisfactory operation and maintenance that the operating and maintenance personnel are fully familiar with the design and that the said personnel have received thorough training in operating and maintaining the machine/unit/equipment. It is further essential for the safe operation of the machine/unit/equipment that personnel has read, understood and followed the safety instructions contained in the manual.

In case of any conflict between terms and conditions of this manual and the contract specifications, drawings, instruction sheets or any other contract-related documents, the contract conditions/documents shall prevail. The contract specific conditions/documents shall apply in priority.

ZKTeco offers no warranty, guarantee or representation regarding the completeness of any information contained in this manual or any of the amendments made thereto. ZKTeco does not extend the warranty of any kind, including, without limitation, any warranty of design, merchantability or fitness for a particular purpose.

ZKTeco does not assume responsibility for any errors or omissions in the information or documents which are referenced by or linked to this manual. The entire risk as to the results and performance obtained from using the information is assumed by the user.

ZKTeco in no event shall be liable to the user or any third party for any incidental, consequential, indirect, special, or exemplary damages, including, without limitation, loss of business, loss of profits, business interruption, loss of business information or any pecuniary loss, arising out of, in connection with, or relating to the use of the information contained in or referenced by this manual, even if ZKTeco has been advised of the possibility of such damages.

This manual and the information contained therein may include technical, other inaccuracies or typographical errors. ZKTeco periodically changes the information herein which will be incorporated into new additions/amendments to the manual. ZKTeco reserves the right to add, delete, amend or modify the information contained in the manual from time to time in the form of circulars, letters, notes, etc. for better operation and safety of the machine/unit/equipment. The said additions or

amendments are meant for improvement /better operations of the machine/unit/equipment and such amendments shall not give any right to claim any compensation or damages under any circumstances.

ZKTeco shall in no way be responsible (i) in case the machine/unit/equipment malfunctions due to any non-compliance of the instructions contained in this manual (ii) in case of operation of the machine/unit/equipment beyond the rate limits (iii) in case of operation of the machine and equipment in conditions different from the prescribed conditions of the manual.

The product will be updated from time to time without prior notice. The latest operation procedures and relevant documents are available on <http://www.zkteco.com>.

If there is any issue related to the product, please contact us.

## ZKTeco Headquarters

**Address** ZKTeco Industrial Park, No. 32, Industrial Road,  
Tangxia Town, Dongguan, China.

**Phone** +86 769 - 82109991

**Fax** +86 755 - 89602394

For business-related queries, please write to us at [sales@zkteco.com](mailto:sales@zkteco.com).

To know more about our global branches, visit [www.zkteco.com](http://www.zkteco.com).

## About the Company

ZKTeco is one of the world's largest manufacturer of RFID and Biometric (Fingerprint, Facial, Finger-vein) readers. Product offerings include Access Control readers and panels, Near & Far-range Facial Recognition Cameras, Elevator/floor access controllers, Turnstiles, License Plate Recognition (LPR) gate controllers and Consumer products including battery-operated fingerprint and face-reader Door Locks. Our security solutions are multi-lingual and localized in over 18 different languages. At the ZKTeco state-of-the-art 700,000 square foot ISO9001-certified manufacturing facility, we control manufacturing, product design, component assembly, and logistics/shipping, all under one roof.

The founders of ZKTeco have been determined for independent research and development of biometric verification procedures and the productization of biometric verification SDK, which was initially widely applied in PC security and identity authentication fields. With the continuous enhancement of the development and plenty of market applications, the team has gradually constructed an identity authentication ecosystem and smart security ecosystem, which are based on biometric verification techniques. With years of experience in the industrialization of biometric verifications, ZKTeco was officially established in 2007 and now has been one of the globally leading enterprises in the biometric verification industry owning various patents and being selected as the National High-tech Enterprise for 6 consecutive years. Its products are protected by intellectual property rights.

## About the Manual

This manual introduces the operations of **ProID Series Water Resistant RFID Access Control Reader**.

All figures displayed are for illustration purposes only. Figures in this manual may not be exactly consistent with the actual products.

Features and parameters with ★ are not available in all devices.





## Document Conventions

Conventions used in this manual are listed below:

### GUI Conventions

For Software	
Convention	Description
<b>Bold font</b>	Used to identify software interface names e.g., <b>OK, Confirm, Cancel.</b>
>	Multi-level menus are separated by these brackets. For example, File > Create > Folder.
For Device	
Convention	Description
< >	Button or key names for devices. For example, press <OK>.
[ ]	Window names, menu items, data table, and field names are inside square brackets. For example, pop up the [New User] window.
/	Multi-level menus are separated by forwarding slashes. For example, [File/Create/Folder].

### Symbols

Convention	Description
	This represents a note that needs to pay more attention to.
	The general information which helps in performing the operations faster.
	The information which is significant.
	Care taken to avoid danger or mistakes.
	The statement or event that warns of something or that serves as a cautionary example.

## Table of Contents

<b>1 OVERVIEW</b> .....	<b>6</b>
1.1 INTRODUCTION .....	6
1.2 FEATURES .....	6
1.3 APPEARANCE .....	6
1.4 SPECIFICATIONS .....	8
<b>2 TERMINAL AND WIRING DESCRIPTION</b> .....	<b>9</b>
2.1 TERMINAL DESCRIPTION .....	9
2.2 WIRING DESCRIPTION .....	10
2.2.1 POWER WIRING .....	10
2.2.2 CONTROLLER CONNECTION .....	10
2.2.3 ACCESS CONTROL DEVICE CONNECTION .....	12
2.2.4 TAMPER SWITCH CONNECTION .....	13
<b>3 INSTALLATION SET-UP</b> .....	<b>14</b>
3.1 INSTALL ON THE WALL .....	14
3.2 MOUNTING ON THE WALL THROUGH ASIAN GANG BOX .....	15
<b>APPENDIX 1 BUZZER, INDICATOR LIGHT PROMPT INSTRUCTIONS</b> .....	<b>16</b>
<b>APPENDIX 2 PRIVACY POLICY</b> .....	<b>17</b>
<b>APPENDIX 3 ECO-FRIENDLY OPERATION</b> .....	<b>19</b>

# 1 Overview

## 1.1 Introduction

ProID series metal reader is the latest access control reader launched by ZKTeco, which can be used with access control machines for more cost-effective use of access control. There are two colors of black and white for customers to choose, using three installation specifications (Asian gang box, single gang box and mullion mount), standard ID, optional MF, recognition of the card distance of 0-5cm, support Wiegand and RS-485.

## 1.2 Features

- High stability and energy efficiency.
- On-site adjustable Wiegand output (26 or 34 bits).
- Dust and water resistant (IP65), ideal for indoor and outdoor applications.
- Black or white color available.

## 1.3 Appearance

### ProID101

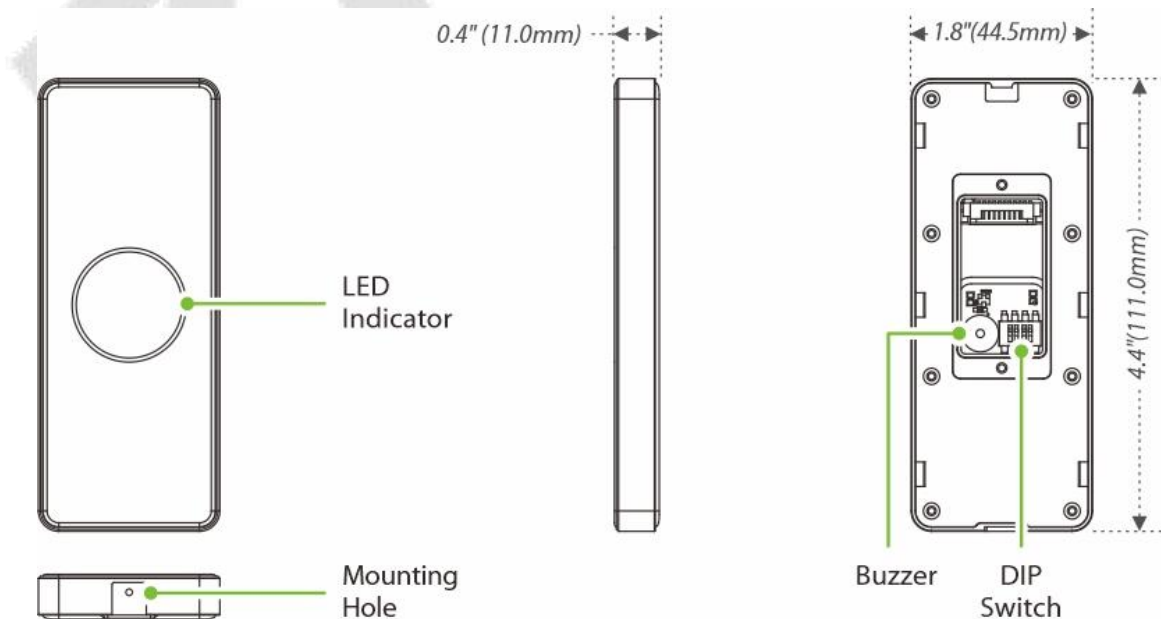

### ProID102

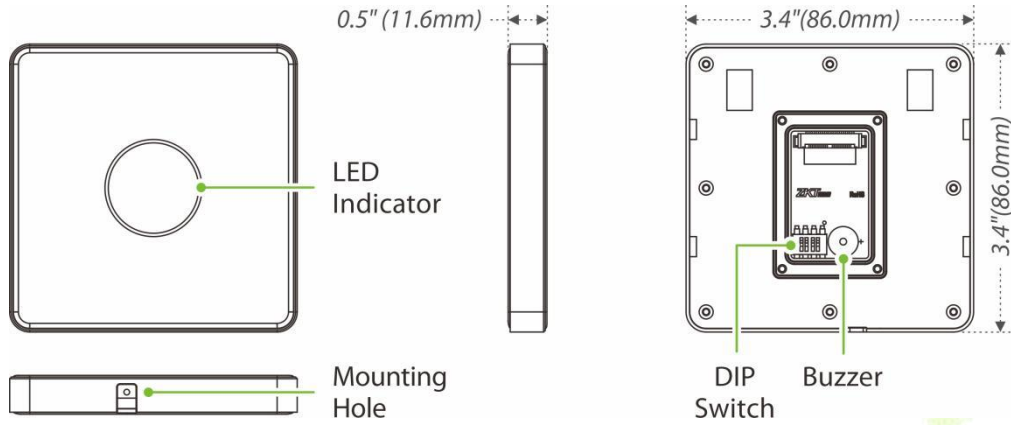

### ProID103

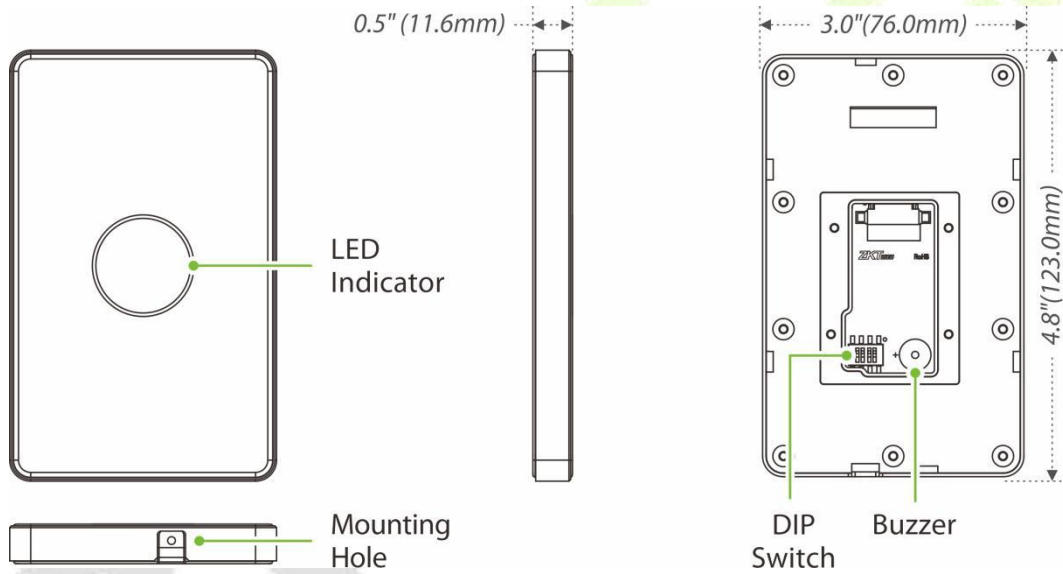

### Back Plate

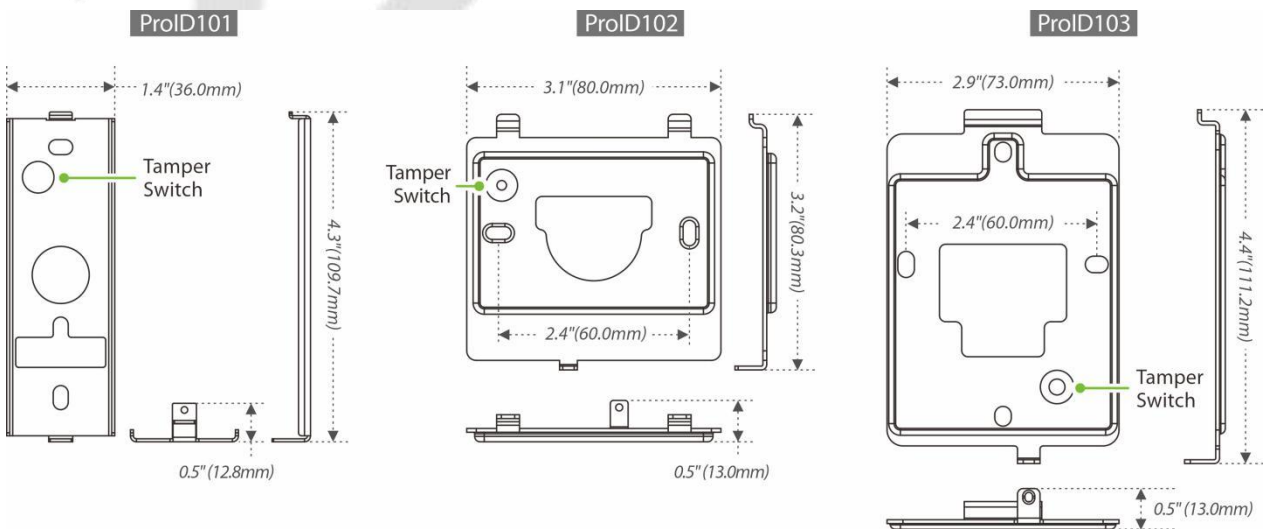

Figure 1-1 ProID series water resist and RFID access control reader appearance



## 1.4 Specifications

Items	Specifications
Operation Voltage	7 to 13V DC
Current Draw	≤350mA 5V
Processor	32-bit ARM Cortex-M0 48MHz
Card Type	ID/IC Card
Read Range	0 to 3 cm
Output Format	Wiegand 26bit or 34bit (Adjustable), RS485
Operating Temperature	-20 °C to 65 °C
Operating Humidity	10% to 90% RH, Non-Condensing
Protection Rating	IP65, IK04
Installation	Asian gang box, single gang box, mullion mount
Color	Black & White
Certification	ISO9001, ISO14001, CE, FCC

## 2 Terminal and Wiring Description

### 2.1 Terminal Description

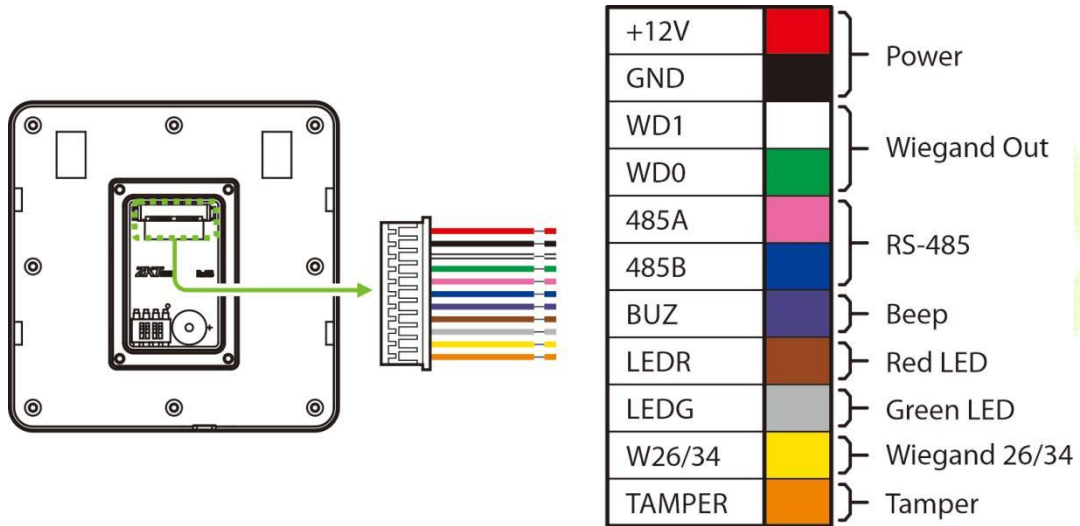

Figure 2-1 Terminal Description

Table 2-1 Description of Terminal and Interfaces

Name	Interface	Description
<b>Power</b>	+12V	7 to 13V DC Input
	GND	<b>Note:</b> Recommended AC adapter: <b>7 to 13V</b> , Current Draw $\leq 350mA$ 5V.
<b>Wiegand Out</b>	WD1	Wiegand Output1
	WD0	Wiegand Output0
<b>RS-485</b>	485A	RS-485 Communication Interface
	485B	
<b>Beep</b>	BUZ	Beep Input
<b>Red LED</b>	LEDR	Red LED Interface
<b>Green LED</b>	LEDG	Green LED Interface
<b>Wiegand 26/34</b>	W26/34	Wiegand Output Bits <b>Note:</b> When terminal WG26/34 is connected to ground, the number of Wiegand output bits is 26 bits. The default is not grounded, and the number of Wiegand output bits is 34 bits.
<b>Tamper</b>	TAMPER	Tamper Switch

## 2.2 Wiring Description

### 2.2.1 Power Wiring

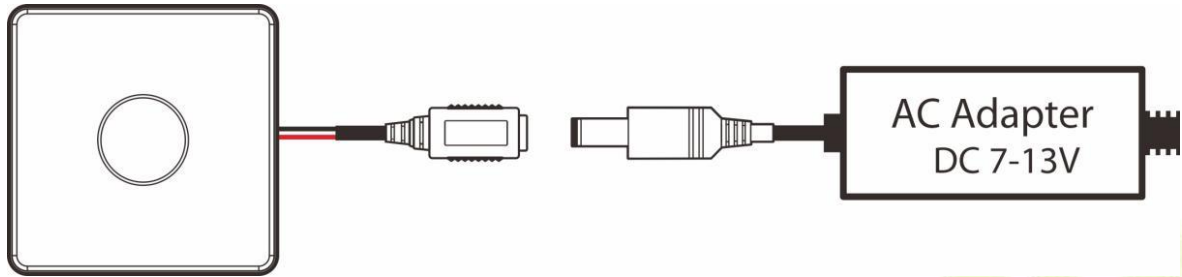

Figure 2-2 Power Wiring

**Notes:**

- Recommended AC adapter: **7 to 13V**, Current Draw  $\leq 350\text{mA}$  5V.
- Use an AC adapter with a higher current rating to share power with the other devices.

### 2.2.2 Controller Connection

This ProLD series reader needs to be connected to a host machine in order to transmit card information via RS-485 or wiegand. The following is an example of the connection to InBio Series controller.

#### 2.2.2.1 Connect the controller via RS485

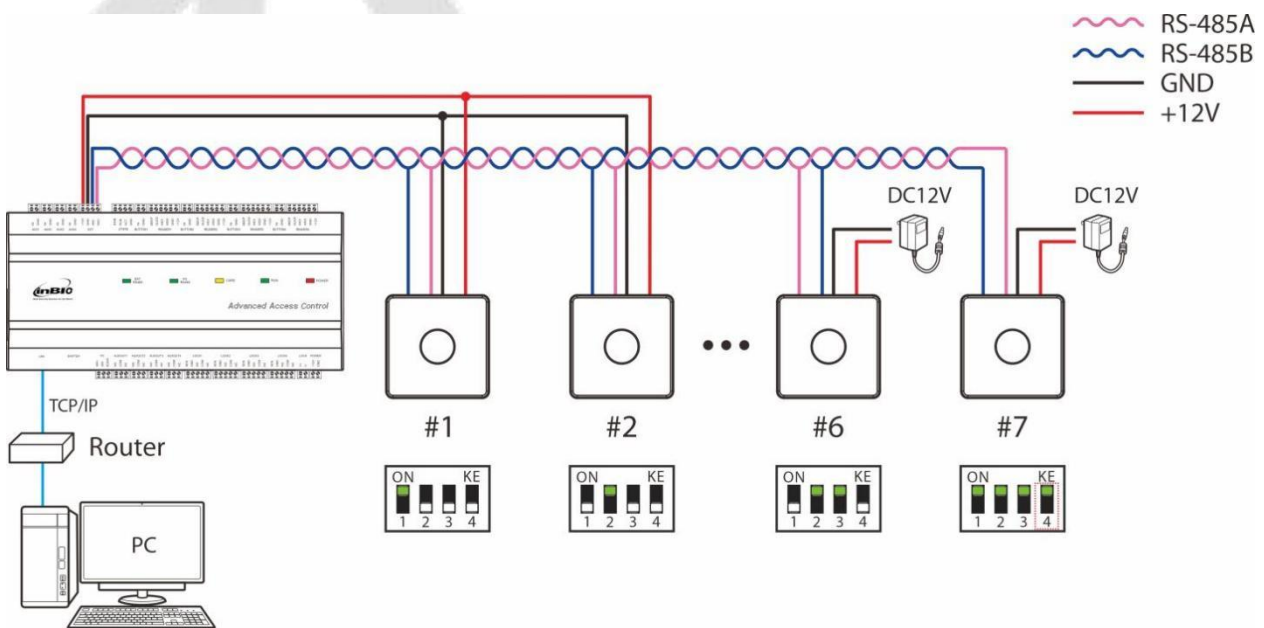

Figure 2-3 Reader connect the controller via RS-485

**Notes:**

1. A maximum of seven readers can be connected to one controller.
2. Before connecting RS-485 readers, open the rear panel of the reader and set the RS-485 address of the reader via DIP switch according to the connection of each reader.
3. If the RS-485 communication wire is longer than 100 meters, it is needed to set the 4th DIP switch of the last reader to ON state.
4. The DIP switch needs to be set with the controller powered off and takes effect after restart. After setting, the DIP switch does not need to be set back to its original position.
5. For details on how to add controllers and readers to the software, please refer to the relevant User Manual.

**DIP Switch Settings**

As shown in the table below, places 1-3 of the DIP switch are used to set the device number for RS-485 communication, and place 4 is for setting the RS-485 termination resistance. If the RS-485 communication wire is longer than 100 meters, it is needed to set the 4th DIP switch of the last reader to **ON** state, that is parallel a terminal resistance of **120** ohm between 485+ and 485-.

**Table 2-2** DIP switch settings

DIP Switch	485 Address	Switch Setting
	1	
	2	
	3	
	4	
	5	
	6	
	7	

### 2.2.2.2 Connect the controller via Wiegand

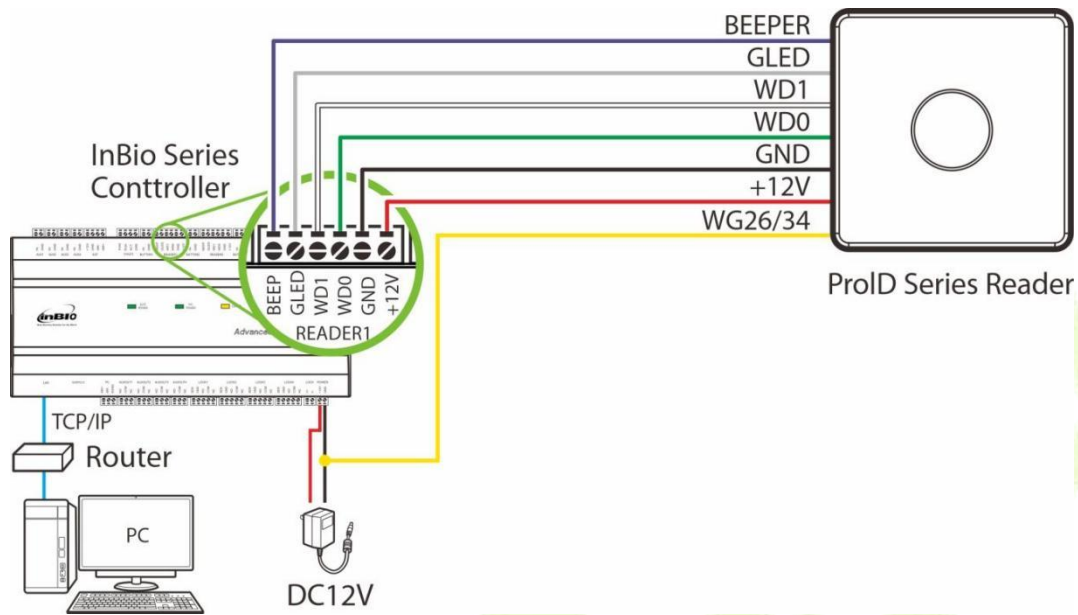

**Figure 2-4** Reader connect the controller via Wiegand

**Notes:**

- When terminal WG26/34 is connected to ground, the number of Wiegand output bits is 26 bits. The default is not grounded, and the number of Wiegand output bits is 34 bits.

### 2.2.3 Access Control Device Connection

This ProLD series reader can be connected to an access control device. The wiring below is an example of connection to an access control device via RS-485.

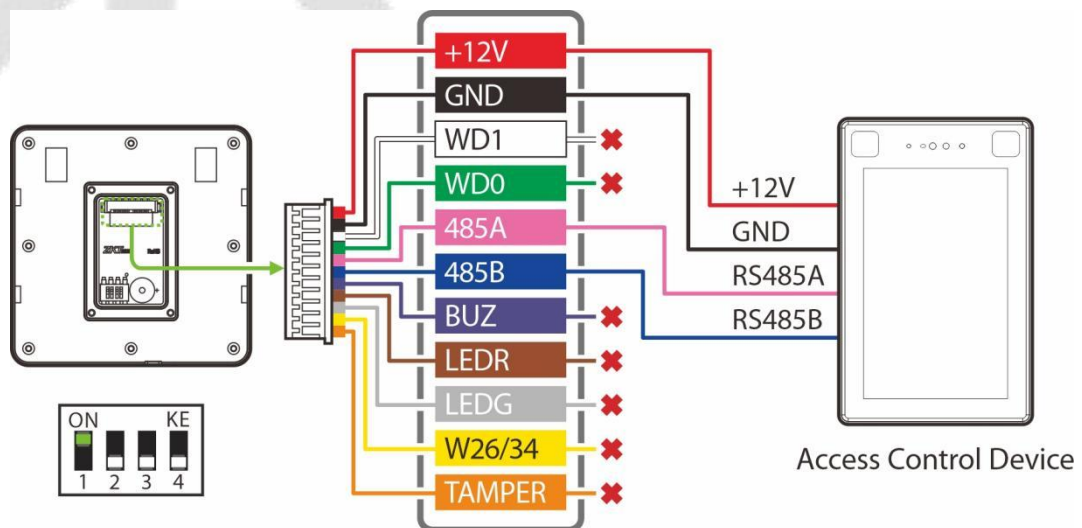

**Figure 2-5** Reader connect the access control device

**Notes:**

- The reader RS-485 address defaults to 1.

### 2.2.4 Tamper Switch Connection

When the tamper switch terminal is successfully connected to the controller, the device will not only send an alarm when the back panel of the device is opened, but also send an alarm signal to the software side.

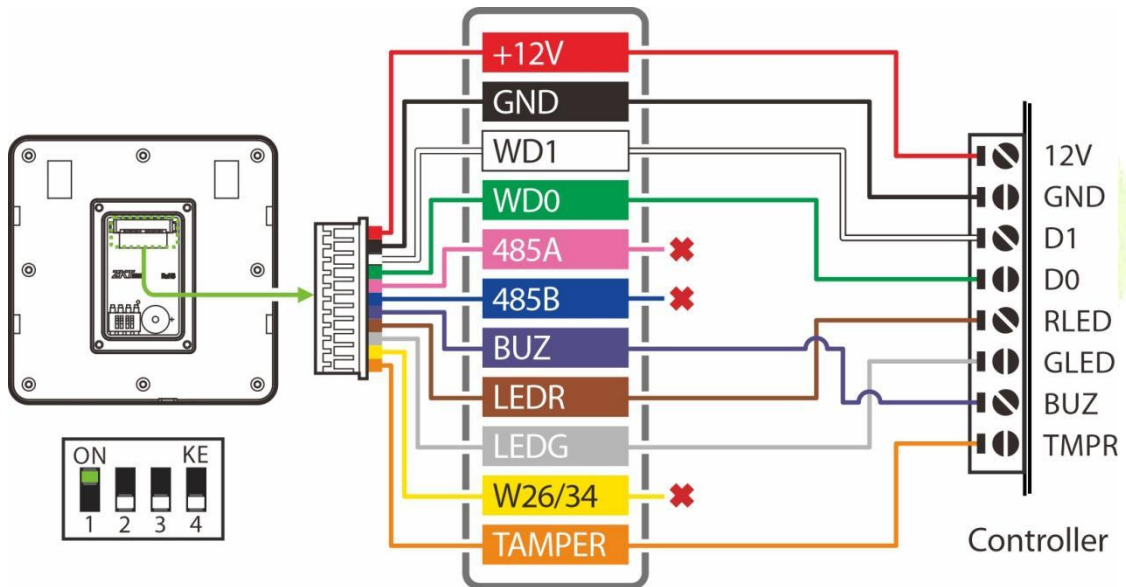

Figure 2-6 Tamper switch terminal connection

### 3 Installation Set-up

ProID series reader can be installed on the wall alone or mounted to the wall by Asian gang box, single gang box and mullion mount. The following is an example of wall mounting and Asian gang box installation of ProID102. The installation steps are introduced as shown below.

Make sure that the device is installed as per the installation instructions. Otherwise, you will bear any consequence resulting from your actions.

#### 3.1 Install on the wall

**Step 1:** Attach the mounting template sticker to the wall, and drill holes according to the mounting paper. The recommended installation height from the ground is 1.5 meters, which can be adjusted appropriately according to actual needs.

**Step 2:** Secure the back plate on the wall with the wall mounting screws.

**Step 3:** After passing the wires through the wiring hole and connecting them to the device, and then attach the device to the back plate from top to bottom.

**Step 4:** Fasten the device to the back plate with a security screw.

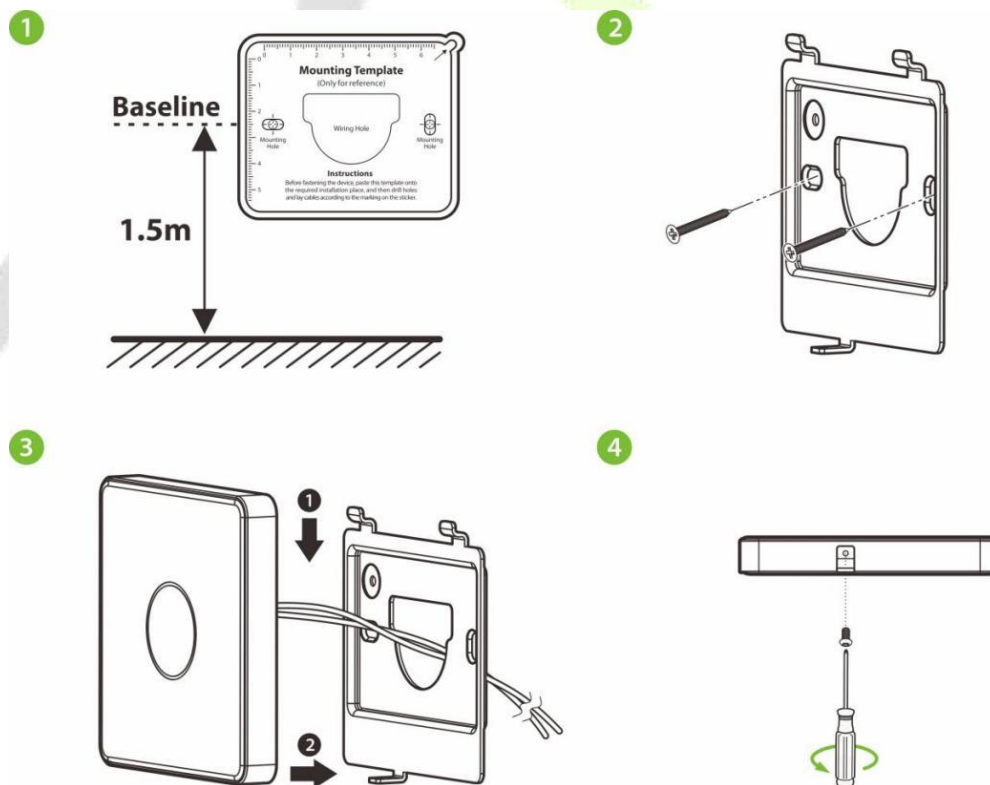

**Figure 3-1** Install the ProID series reader on the wall

**Note:**

- The installation method of ProID101 and ProID103 is the same as that of ProID102. Only ProID102 is used as an example, and will not be repeated here again.

## 3.2 Mounting on the wall through Asian gang box

**Step 1:** Install the Asian gang box (or single gang box, mullion mount) into the wall.

**Step 2:** Fix the back plate onto the Asian gang box (or single gang box, mullion mount) using two wall mounting screws.

**Step 3:** Pass the cables through the wire hole.

**Step 4:** Then insert the device into back plate.

**Step 5:** Use security screw to fasten the device to the back plate.

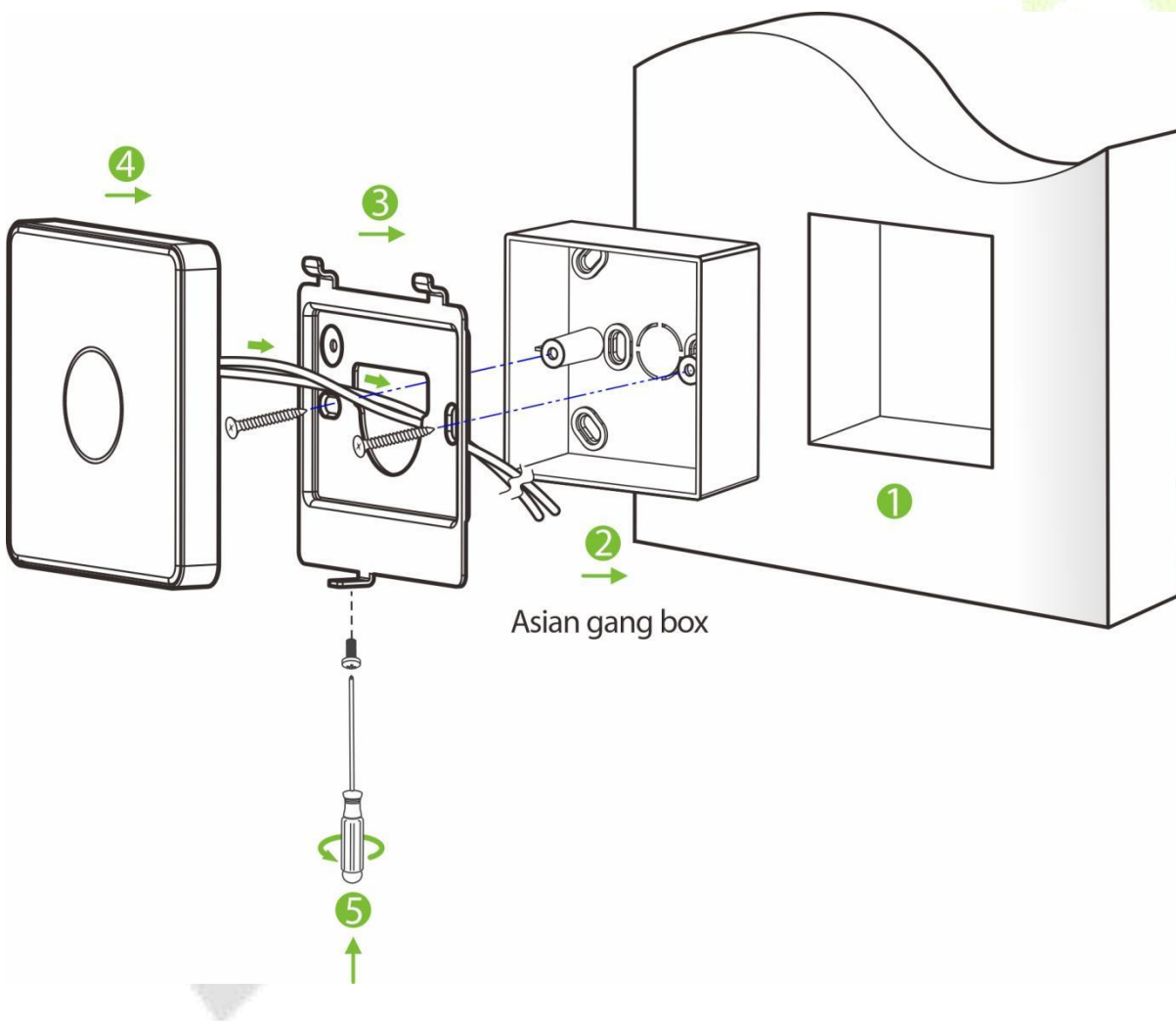

**Figure 3-2** Install the ProID series reader on the wall through Asian gang box

**Note:**

- The installation method of single gang box is the same as that of Asian gang box. Only Asian gang box installation method is illustrated as an example in this quick start guide.



## Appendix 1 Buzzer, Indicator Light Prompt Instructions

When the reader communicates via RS-485, the status of the buzzer and the indicator is shown in the table below. Note that when communicating via Wiegand, the status of the buzzer and indicator is controlled by the controller or the all-in-one access control device.

**Table 4-1** Buzzer, Indicator Light Prompt Instructions

Working Status	Indicator Light	Buzzer
When the reader is powered on.	LED bright white light, then switch to white light breathing state after 4s.	1 short sound
When punching the card.	LED bright white light.	1 short sound
Card is registered	LED indicator lights green.	1 short sound
Card not registered	LED indicator (red) lights up briefly twice.	2 short sound
If the communication is not normal, there will be a state that the host does not poll.	5 seconds after the timeout, the white light flashes 3 times	3 short sound

## Appendix 2 Privacy Policy

### **Notice:**

To help you better use the products and services of ZKTeco and its affiliates, hereinafter referred as “we”, “our”, or “us”, the smart service provider, we consistently collect your personal information. Since we understand the importance of your personal information, we took your privacy sincerely and we have formulated this privacy policy to protect your personal information. We have listed the privacy policies below to precisely understand the data and privacy protection measures related to our smart products and services.

**Before using our products and services, please read carefully and understand all the rules and provisions of this Privacy Policy. If you do not agree to the relevant agreement or any of its terms, you must stop using our products and services.**

### **I. Collected Information**

To ensure the normal product operation and help the service improvement, we will collect the information voluntarily provided by you or provided as authorized by you during registration and use or generated as a result of your use of services.

- 1. User Registration Information:** At your first registration, the feature template (**Fingerprint template/Face template/Palm template**) will be saved on the device according to the device type you have selected to verify the unique similarity between you and the User ID you have registered. You can optionally enter your Name and Code. The above information is necessary for you to use our products. If you do not provide such information, you cannot use some features of the product regularly.
- 2. Product information:** According to the product model and your granted permission when you install and use our services, the related information of the product on which our services are used will be collected when the product is connected to the software, including the Product Model, Firmware Version Number, Product Serial Number, and Product Capacity Information. **When you connect your product to the software, please carefully read the privacy policy for the specific software.**

### **II. Product Security and Management**

- 1.** When you use our products for the first time, you shall set the Administrator privilege before performing specific operations. Otherwise, you will be frequently reminded to set the Administrator privilege when you enter the main menu interface. **If you still do not set the Administrator privilege after receiving the system prompt, you should be aware of the possible security risk (for example, the data may be manually modified).**
- 2.** All the functions of displaying the biometric information are disabled in our products by default. You can choose Menu > System Settings to set whether to display the biometric information. If you enable these functions, we assume that you are aware of the personal privacy security risks specified in the privacy policy.

3. Only your user ID is displayed by default. You can set whether to display other user verification information (such as Name, Department, Photo, etc.) under the Administrator privilege. **If you choose to display such information, we assume that you are aware of the potential security risks (for example, your photo will be displayed on the device interface).**
4. The camera function is disabled in our products by default. If you want to enable this function to take pictures of yourself for attendance recording or take pictures of strangers for access control, the product will enable the prompt tone of the camera. **Once you enable this function, we assume that you are aware of the potential security risks.**
5. All the data collected by our products is encrypted using the AES 256 algorithm. All the data uploaded by the Administrator to our products are automatically encrypted using the AES 256 algorithm and stored securely. If the Administrator downloads data from our products, we assume that you need to process the data and you have known the potential security risk. In such a case, you shall take the responsibility for storing the data. You shall know that some data cannot be downloaded for sake of data security.
6. All the personal information in our products can be queried, modified, or deleted. If you no longer use our products, please clear your personal data.

### III. How we handle personal information of minors

Our products, website and services are mainly designed for adults. Without consent of parents or guardians, minors shall not create their own account. If you are a minor, it is recommended that you ask your parents or guardian to read this Policy carefully, and only use our services or information provided by us with consent of your parents or guardian.

We will only use or disclose personal information of minors collected with their parents' or guardians' consent if and to the extent that such use or disclosure is permitted by law or we have obtained their parents' or guardians' explicit consent, and such use or disclosure is for the purpose of protecting minors.

Upon noticing that we have collected personal information of minors without the prior consent from verifiable parents, we will delete such information as soon as possible.

### IV. Others

You can visit [https://www.zkteco.com/cn/index/Index/privacy\\_protection.html](https://www.zkteco.com/cn/index/Index/privacy_protection.html) to learn more about how we collect, use, and securely store your personal information. To keep pace with the rapid development of technology, adjustment of business operations, and to cope with customer needs, we will constantly deliberate and optimize our privacy protection measures and policies. Welcome to visit our official website at any time to learn our latest privacy policy.

## Appendix 3 Eco-friendly Operation



The product's "eco-friendly operational period" refers to the time during which this product will not discharge any toxic or hazardous substances when used in accordance with the prerequisites in this manual.

The eco-friendly operational period specified for this product does not include batteries or other components that are easily worn down and must be periodically replaced. The battery's eco-friendly operational period is 5 years.

### Hazardous or Toxic substances and their quantities

Component Name	Hazardous/Toxic Substance/Element					
	Lead (Pb)	Mercury (Hg)	Cadmium (Cd)	Hexavalent Chromium (Cr6+)	Polybrominated Biphenyls (PBB)	Polybrominated Diphenyl Ethers (PBDE)
Chip Resistor	×	○	○	○	○	○
Chip Capacitor	×	○	○	○	○	○
Chip Inductor	×	○	○	○	○	○
Diode	×	○	○	○	○	○
ESD component	×	○	○	○	○	○
Buzzer	×	○	○	○	○	○
Adapter	×	○	○	○	○	○
Screws	○	○	○	×	○	○

○ indicates that the total amount of toxic content in all the homogeneous materials is below the limit as specified in SJ/T 11363—2006.

× indicates that the total amount of toxic content in all the homogeneous materials exceeds the limit as specified in SJ/T 11363—2006.

**Note:** 80% of this product's components are manufactured using non-toxic and eco-friendly materials. The components which contain toxins or harmful elements are included due to the current economic or technical limitations which prevent their replacement with non-toxic materials or elements.

# Green Label

ZKTeco Industrial Park, No. 32, Industrial Road,  
Tangxia Town, Dongguan, China.

Phone : +86 769 - 82109991

Fax : +86 755 - 89602394

[www.zkteco.com](http://www.zkteco.com)

