



X-ray Security Inspection System Maintenance Manual

Version: 1.0 Date: November 2017



First of all, thank you for your trust in ZKTECO and selection of our "security inspection" product! This product is subject to strict quality control. Although the components have long service life, the ageing of roller bearing and wear of conveying belt are inevitable during operation, which will not lead to the stop of equipment but will increase the failure rate. It is recommended to conduct regular maintenance in order to ensure normal operation.

We will sincerely provide high-quality maintenance services, with good attitude, professional technician team (the members have received the regular and rigorous technical training and obtained appropriate certificates) and original component sources.

The products may be improved or upgraded without prior notice. The equipment structure and circuit may differ from that in kind. Your understanding and support will be appreciated.

Contents

- 1. Simple Faults and Troubleshooting.....1
 - 1.1 Failure of Startup after Powering-on.....1
 - 1.2 Red “Emergency” in Lower Right Corner of LCD (Computer Display) and Failure of Roller Motor (Fig. 1-4).....2
 - 1.3 No Image of “Inspected Bag” during Normal Operation.....3
 - 1.4 Red “System Error” in the Lower Right Corner of LCD (Computer Display) after Startup4
 - 1.5 Failure of AC Roller Motor (if any) of Belt during Normal Operation6
- 2. Component Replacement.....7
 - 2.1 Relay Replacement.....7
 - 2.2 Contactor Replacement.....8
 - 2.3 Replacement of Roller Motor Controller (for 5030).....9
 - 2.4 Fuse Replacement.....9
 - 2.5 Replacement of Emergency Stop Button.....10
 - 2.6 Indicator Replacement11
 - 2.7 Replacement of Key Switch and Start Button12
 - 2.8 Replacement of Air Switch.....13
 - 2.9 Replacement of Roller Motor15
 - 2.10 Replacement of Driven Roller16
 - 2.11 Replacement of Supporting Roller.....17
 - 2.12 Replacement of X-ray Generator18

2.13 Replacement of Lead Curtain	19
2.14 Replacement of Conveyor Belt.....	20
3. Control Board PCBA, X-ray Generator LED Indicator and Interface.....	21
3.1 Interface of Control Board PCBA.....	21
3.2 LED Indicator and Interface of X-ray Generator.....	23
4. Interpretation of Electrical Diagram.....	25
4.1 Interpretation of Electrical Diagram.....	25
5. Maintenance.....	30
5.1 Dust Removal	30
5.2 Component Replacement.....	33

1. Simple Faults and Troubleshooting

1.1 Failure of Startup after Powering-on

If the equipment cannot be started normally, first check the power voltage (normally AC 200V-240V) (Fig. 1-1). In the case of no or abnormal voltage, check the power supply circuit until the voltage is normal. If the voltage is normal but the equipment cannot be started, check whether the voltage between the terminals 1 and 3 is 200V-240V (Fig. 1-2). If the anomaly still occurs, check whether the air switch trips and whether the fuse is broken. Replace the broken fuse (Fig. 1-3). Then check whether the plug in the power outlet is installed properly. If the above components are in good conditions but the equipment cannot be started normally, please call the repair personnel of the manufacturer.



Fig. 1-1



Fig. 1-2

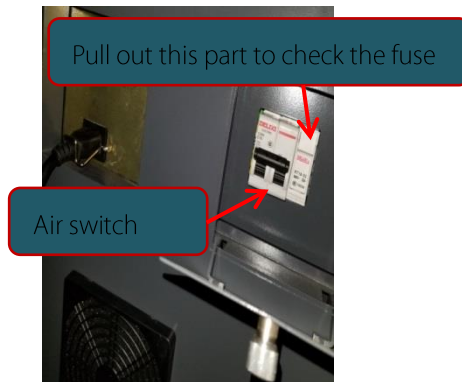

Fig. 1-3

1.2 Red “Emergency” in Lower Right Corner of LCD (Computer Display) and Failure of Roller Motor (Fig. 1-4)

In the above case, first check whether the “Emergency Stop Button” is pressed. Normally, two “Emergency Stop Buttons” are provided (Fig. 1-5). If the console is provided, there is an “Emergency Stop Button” on its “Special Keyboard”. Release the pressed emergency stop button by rotating it clockwise, and then press “Start” to restore normal operation. If “Emergency” is still displayed, check two “Micro Switches”. Under normal circumstances, the two “Side Doors” in the tightened state will be against the “Micro Switches” (Fig. 1-6). The “Emergency” fault may occur if one “Side Door” is not against the “Micro Switch” as a result of loosening. Eliminate the fault, and press “Start” to restore normal operation. If the above items are in good conditions but the equipment does not work normally, please call the repair personnel of the manufacturer.



Fig. 1-4

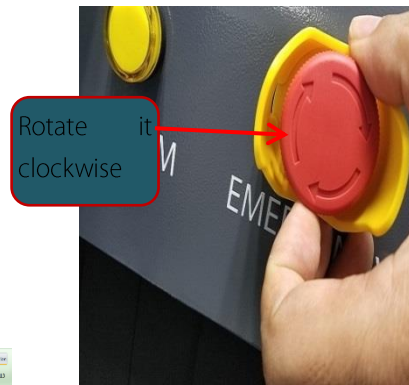

Fig. 1-5

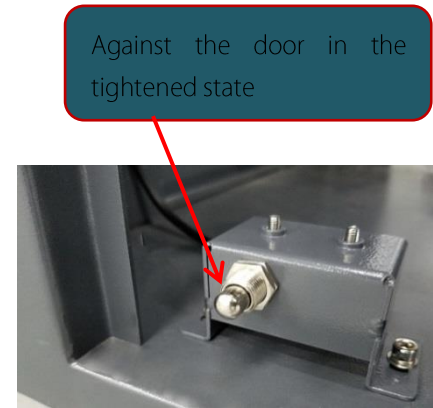

Fig. 1-6

1.3 No Image of “Inspected Bag” during Normal Operation

If the equipment works normally but the image of the “inspected bag” is not displayed, check whether the “Optical Path” (small hole of the iron plate and surfaces of the transmitting and receiving ends of the photoelectric switches) of the photoelectric switches is blocked by debris such as dust during long-term operation. If necessary, remove the photoelectric switches (Fig. 1-7 and 1-8), clean the “Optical Path”, and reinstall the photoelectric switches (note: clean two photoelectric switches, as they are used as a pair). Then restart the equipment. If the image is still abnormal and the red text “System Error” (Fig. 1-9) appears in the lower right corner of the LCD (computer display), refer to Section 1.4.

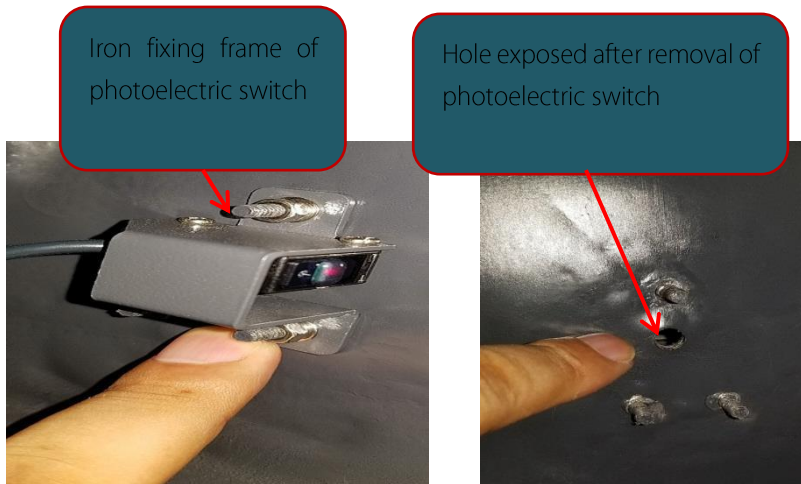

Fig. 1-7

Fig. 1-8

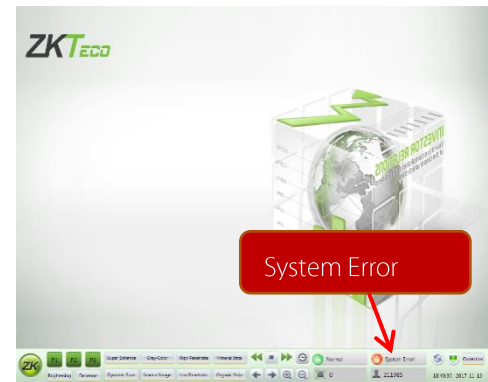

Fig. 1-9

1.4 Red “System Error” in the Lower Right Corner of LCD (Computer Display) after Startup

This may be caused by the fault of “transmission system” and “control panel connection”.

Double-click “System Error”. If “Sensor link error” appears (Fig. 1-10), it indicates that the power or transmission network cable of the “Transmission Board” (in the small iron box beside the “L-shaped Frame”) is faulty. Check whether the power plug on the “Transmission Board” (Fig. 1-11) is loose or in poor contact, and pull out and insert it again. Check whether the plug of the transmission network cable is in good conditions, and pull out and insert again this plug and the network cable plug of IPC (industrial personal computer) board (Fig. 1-12). Restart the equipment. If the fault is still not eliminated, please call the repair personnel of the manufacturer.

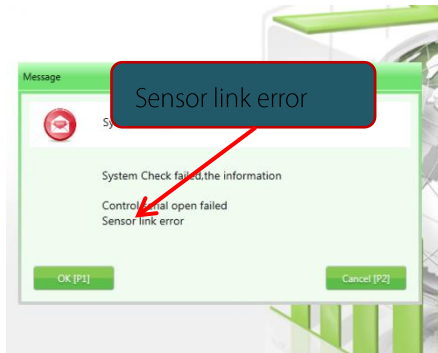

Fig. 1-10

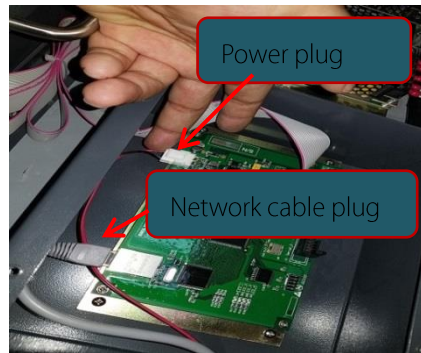

Fig. 1-11

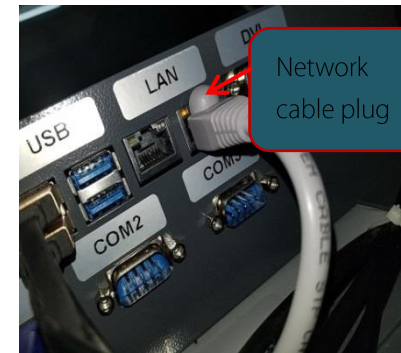

Fig. 1-12

Double-click "System Error". If the control board connection is incorrect (Fig. 1-13), check whether the power interface of the control board is in poor contact (Fig. 1-14), whether the voltage (DC 12V) is normal, whether the connecting cable between the control board and IPC is connected improperly (Fig. 1-15), and whether the COM1 interface of IPC is loose (Fig. 1-16). If the fault still exists after the above troubleshooting and restart, please call the repair personnel of the manufacturer.

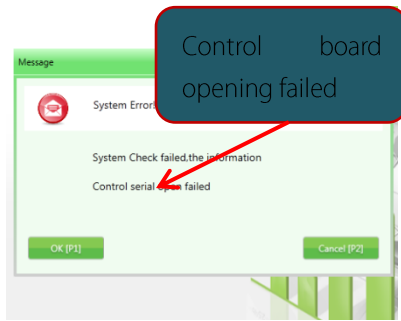

Fig. 1-13

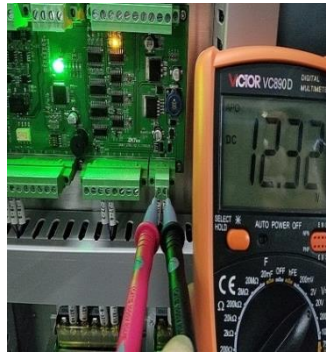

Fig. 1-14



Fig. 1-15



Fig. 1-16

1.5 Failure of AC Roller Motor (if any) of Belt during Normal Operation

Check whether the “Overcurrent Protector” (DZ108-20) trips (that is, overcurrent tripping, generally caused by overload). This fault can be recovered manually (press the ON button of DZ108-20, as shown in Fig. 1-17). As the thermal element is used, you should wait for a moment before pressing this button. Once this button is pressed, the motor will work normally. If the thermal element is triggered (the roller motor is hot, subject to overcurrent arising from overload), normal operation will be recovered in a few minutes. If the above items are checked but the roller motor still fails, please call the repair personnel of the manufacturer.



Fig. 1-17

Pay attention to the safety. All components must be replaced with the power supply disconnected (OFF)! The belt tightness and balance must be adjusted (to avoid deviation) after the belt, roller motor, supporting roller and driven roller are replaced.

2. Component Replacement

2.1 Relay Replacement



Fig. 2-1



Fig. 2-2

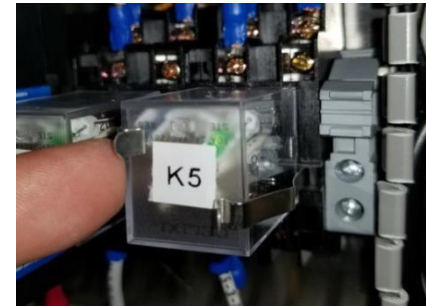

Fig. 2-3

The 240VAC and 10A relay (model: JQX-13F 2Z; brand: DELIXI), with two groups of normally closed contacts, two groups of normally open contacts and coil voltage of DC 12V, is used. The replacement process is as follows: remove the snap spring and relay (Fig. 2-1 and 2-2), and reinstall the relay and snap spring (Fig. 2-3).

2.2 Contactor Replacement

The CJX2sK-09 contactor (brand: DELIXI), with three groups of normally open main contacts, one group of normally open auxiliary contacts, contact current of 9A and coil voltage of AC 220V is used. The removal process is as follows: remove all connecting wires (Fig. 2-4), pull the contactor obliquely upwards by hand (Fig. 2-5) until it is separated from the upper edge of the guide rail, and then remove the contactor by gently pulling it down. The installation process is as follows: clamp the contactor bottom in the original position, pull the contactor up, then fix the contactor by pressing it, and finally connect all wires (Fig. 2-6). (Note: Connect the wires in the original positions. Otherwise, more serious faults may be caused!)

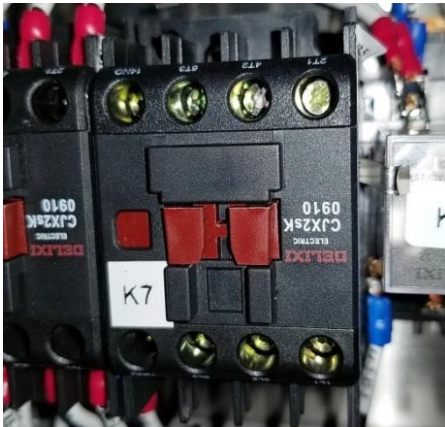

Fig. 2-4

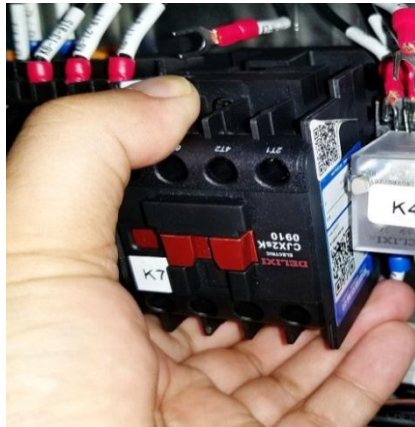

Fig. 2-5



Fig. 2-6

2.3 Replacement of Roller Motor Controller (for 5030)

Remove the fixing screws (as shown in Fig. 2-7) of the roller motor controller, then remove the connecting wires with a screwdriver (Fig. 2-8). Install a new roller motor controller according to the opposite steps. (Note: Connect the wires in the original positions. Otherwise, more serious faults may be caused!)



Fig. 2-7

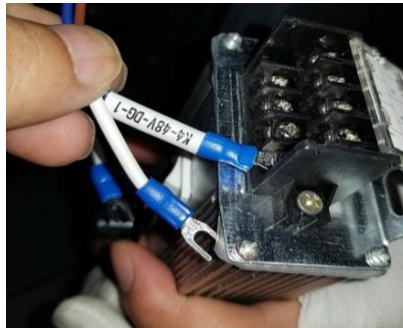

Fig. 2-8

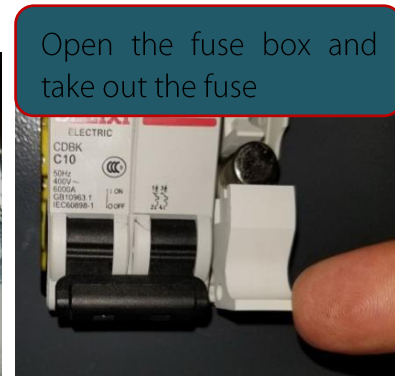

Fig. 2-9

2.4 Fuse Replacement

Open the fuse box, take out the fuse (Fig. 2-9), and install a new fuse.

2.5 Replacement of Emergency Stop Button

Remove the fixing screws and wire screws (Fig. 2-11) of the emergency stop button (Fig. 2-10). Rotate the button counterclockwise (Fig. 2-12), and hold the other end (Fig. 2-13) to remove it. Install a new button according to the opposite steps.



Fig. 2-10

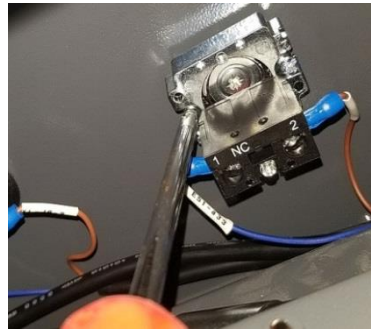

Fig. 2-11



Fig. 2-12



Fig. 2-13

2.6 Indicator Replacement

Take the power indicator as an example (Fig. 2-14). Remove the connecting wire (Fig. 2-15). Then remove the fastening ring behind the indicator by rotating it counterclockwise (Fig. 2-16). Install a new indicator according to the opposite steps.



Fig. 2-14



Fig. 2-15



Fig. 2-16

2.7 Replacement of Key Switch and Start Button

See Fig. 2-17 for the key switch and start button. Remove the plug (Fig. 2-18) of the connecting wire between the key and start button on the back of the top plate. Then remove the protective cover (Fig. 2-19). Refer to “Replacement of Emergency Stop Button” for specific replacement steps.



Fig. 2-17



Fig. 2-18



Fig. 2-19

2.8 Replacement of Air Switch

See Fig. 2-20 for the air switch. First remove all connecting wires of the light controller (Fig. 2-21) and four beam fixing screws (Fig. 2-22), take out the beam (Fig. 2-23), and remove the box (Fig. 2-24) and air switch (Fig. 2-25). Install a new air switch according to the opposite steps.

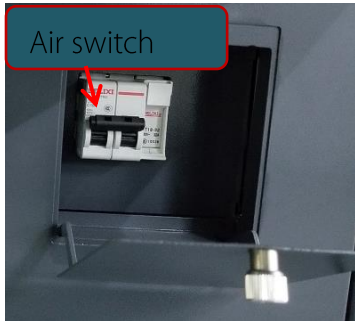

Fig. 2-20



Fig. 2-21

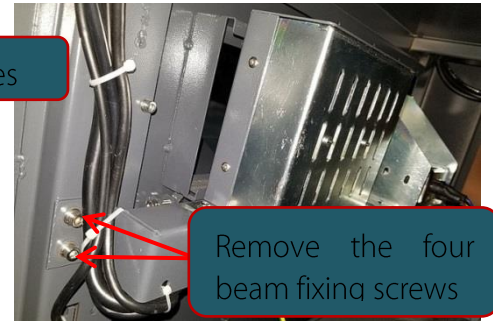

Fig. 2-22



Fig. 2-23



Fig. 2-24

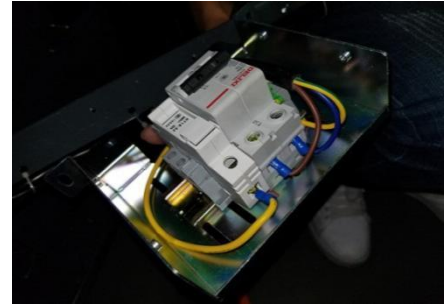

Fig. 2-25

Note: Connect the wires in the original positions. Otherwise, more serious faults may be caused!

2.9 Replacement of Roller Motor

First remove the roller motor wire (remove the motor wire of the DC roller from the roller controller) (Fig. 2-26). Then remove two conveyor covers on the motor side (remove the dust caps of screw holes first and then the covers) (Fig. 2-27). Remove the conveyor guard (Fig. 2-28) and supporting roller assembly (Fig. 2-29), loosen the belt and remove the screws (Fig. 2-30) and motor (Fig. 2-31). Install a new motor according to the opposite steps. (Note: Do not damage the belt while removing the motor!)



Fig. 2-26



Fig. 2-27



Fig. 2-28

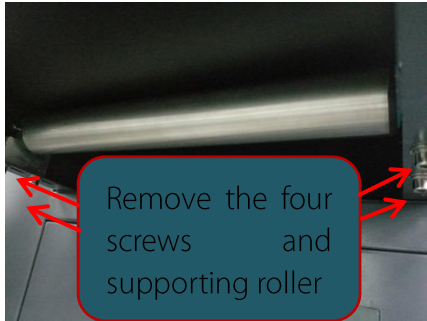

Fig. 2-29



Fig. 2-30



Fig. 2-31

2.10 Replacement of Driven Roller

Refer to the motor replacement steps. Compared with the roller motor, the motor wire is not involved in the driven roller.

2.11 Replacement of Supporting Roller

Remove the conveyor guard (Fig. 2-28) on the supporting roller side. Then remove the supporting roller assembly (Fig. 2-29 and 2-32) and the supporting roller. Install a new roller according to the opposite steps.

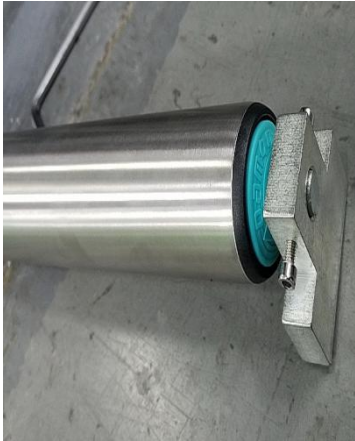

Fig. 2-32

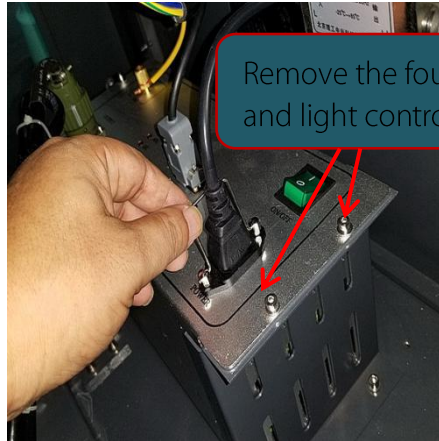

Fig. 2-33

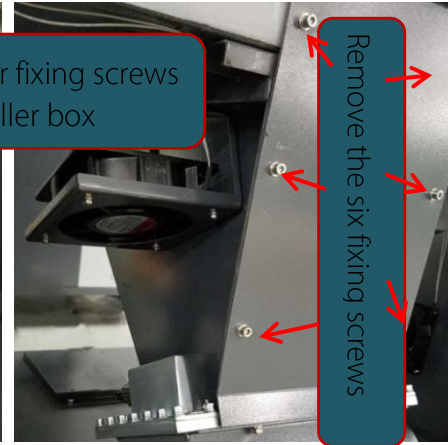

Fig. 2-34

2.12 Replacement of X-ray Generator

The X-ray generator is normally composed of two parts: "Ray Generator Control Box" and "Light Source", which should be replaced at the same time. (They are adjusted at the same time during ray generator production. The significant fault will occur probably or the service life of the ray generator will be shortened if only one part is replaced!) Remove all connecting wires of the "Light Source" and "Ray Generator Control Box", the fixing screws (Fig. 2-33) of "Ray Generator Control Box" and the "Ray Generator Control Box". Then remove the leak-proof lead guard (Fig. 2-34) of the "Light Source", the fixing screws (Fig. 2-35) of the base of the "Light Source", and finally the "Light Source", base and first collimating slit. Install a new X-ray generator according to the opposite steps.

2.13 Replacement of Lead Curtain

The lead curtain is used for shielding X-rays (Fig. 2-36). Open the top plate, and remove the fixing screws (Fig. 2-37) and then the whole lead curtain. Install a new lead curtain according to the opposite steps.



Fig. 2-35



Fig. 2-36

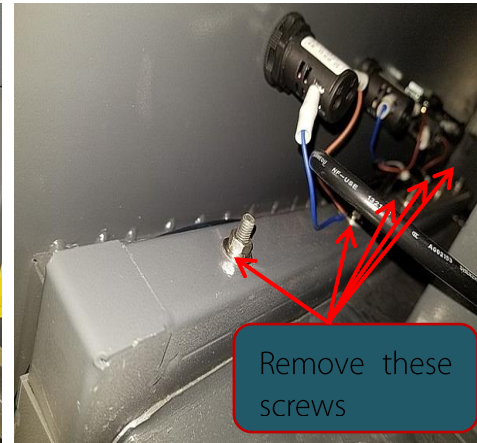

Fig. 2-37

2.14 Replacement of Conveyor Belt

First, move four conveyor belt covers (Fig. 2-38), two conveyor guards (Fig. 2-39) and four fixing screws (Fig. 2-40). Then remove the motor wire and take out the conveyor (Fig. 2-41). Turn the conveyor upside down, and remove the two supporting roller assemblies (Fig. 2-42), two (iron-coated lead) small plates (Fig. 2-42), motor or driven roller and conveyor belt (Fig. 2-43) sequentially. Install a new conveyor belt according to the opposite steps. **(Note: Do not damage the new conveyor belt during installation! Connect the motor wire properly. Otherwise, more serious faults may be caused!)**



Fig. 2-38

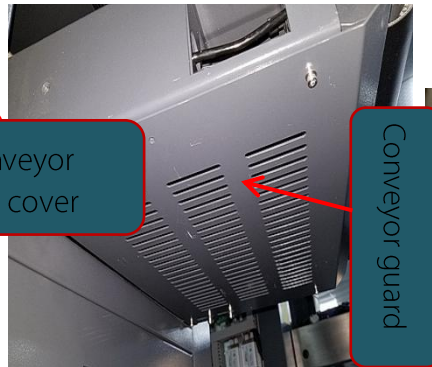

Fig. 2-39

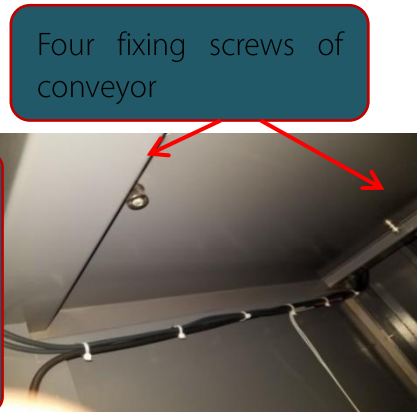

Fig. 2-40



Fig. 2-41

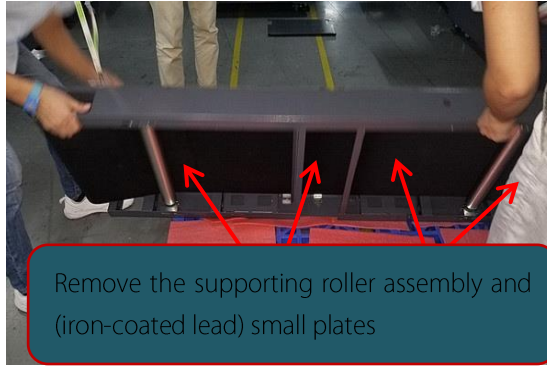

Fig. 2-42



Fig. 2-43

3. Control Board PCBA, X-ray Generator LED Indicator and Interface

3.1 Interface of Control Board PCBA

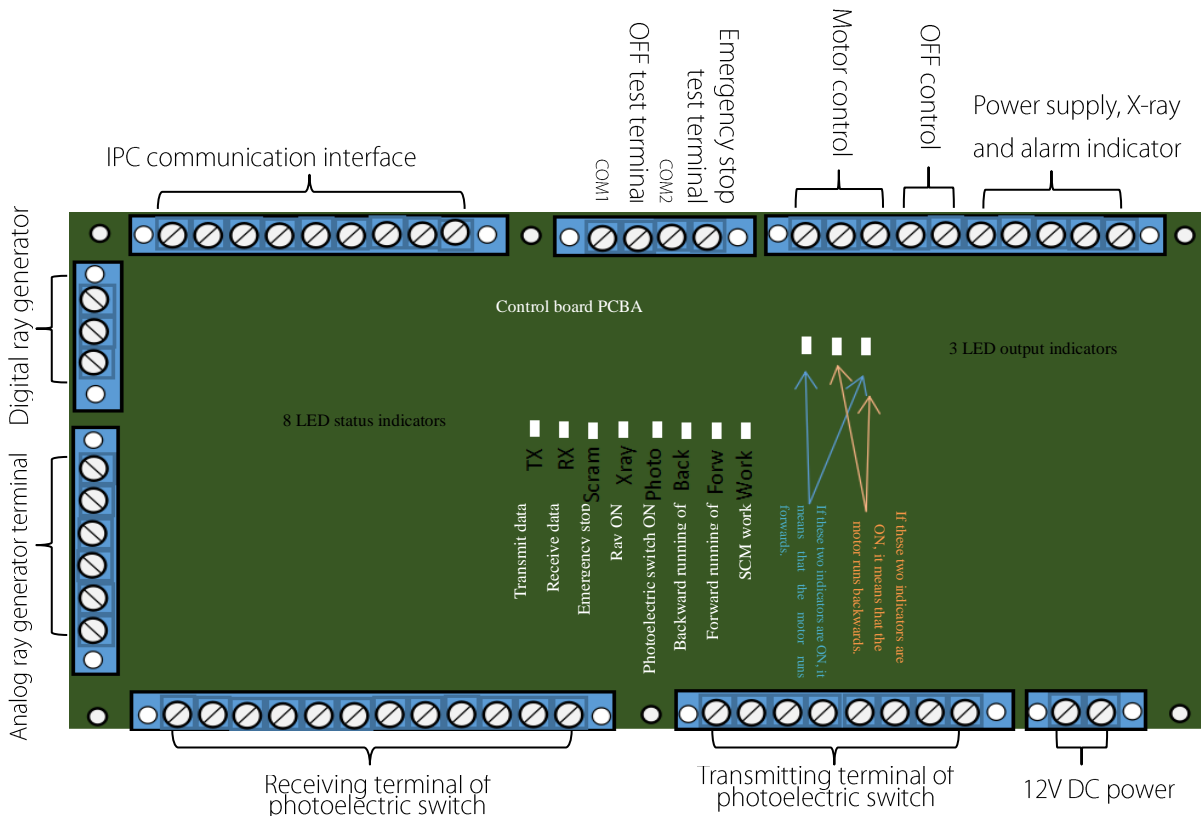

3.2 LED Indicator and Interface of X-ray Generator

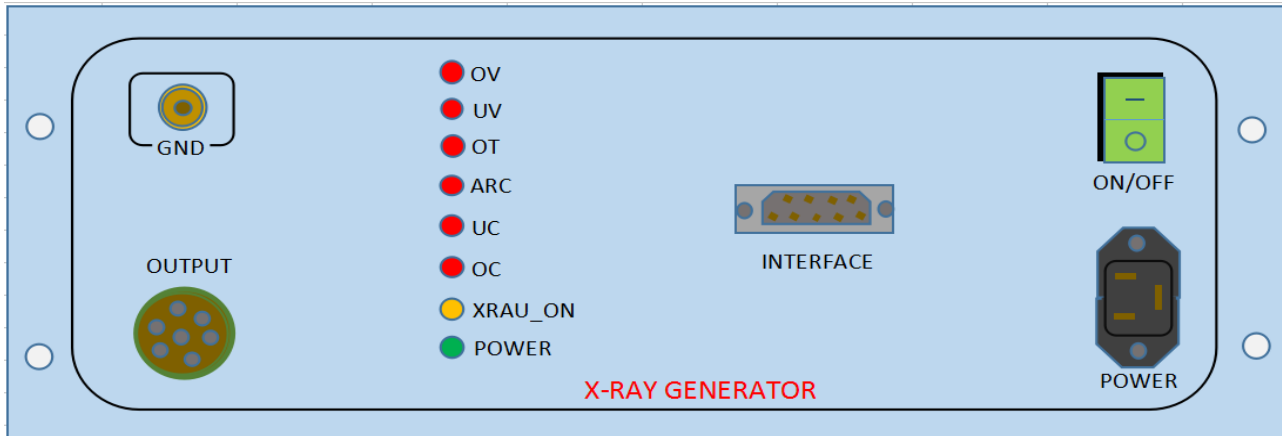

Description of letters on the control box indicators:

POWER: If this indicator is ON, it means that the X-ray generator is powered on.

XRAU_ON: If this indicator is ON, it means that the rays of X-ray generator are enabled (the slight brightness indicates the standby status).

OC: If this indicator is ON, it means that the X-ray generator is subject to overcurrent (the current at the tube end is too high).

UC: If this indicator is ON, it means that the X-ray generator is subject to undercurrent (the current at the tube end is too low).

ARC: If this indicator is ON, it means that serious sparking occurs in the X-ray generator.

OT: If this indicator is ON, it means that the X-ray generator is overheated (the light source is too hot).

UV: If this indicator is ON, it means that the X-ray generator is subject to under-voltage (the voltage at the tube end is too low).

OV: If this indicator is ON, it means that the X-ray generator is subject to over-voltage (the voltage at the tube end is too high).

Description of panel ports:

GND: Grounding terminal of the X-ray generator.

OUTPUT: Aviation plug between the X-ray generator and its control box.

INTERFACE: DB9 (RS232) socket of the X-ray generator controller connected to the control board PCBA.

ON/OFF: Power switch of the X-ray generator.

POWER: Power outlet of the X-ray generator.

4. Interpretation of Electrical Diagram

4.1 Interpretation of Electrical Diagram

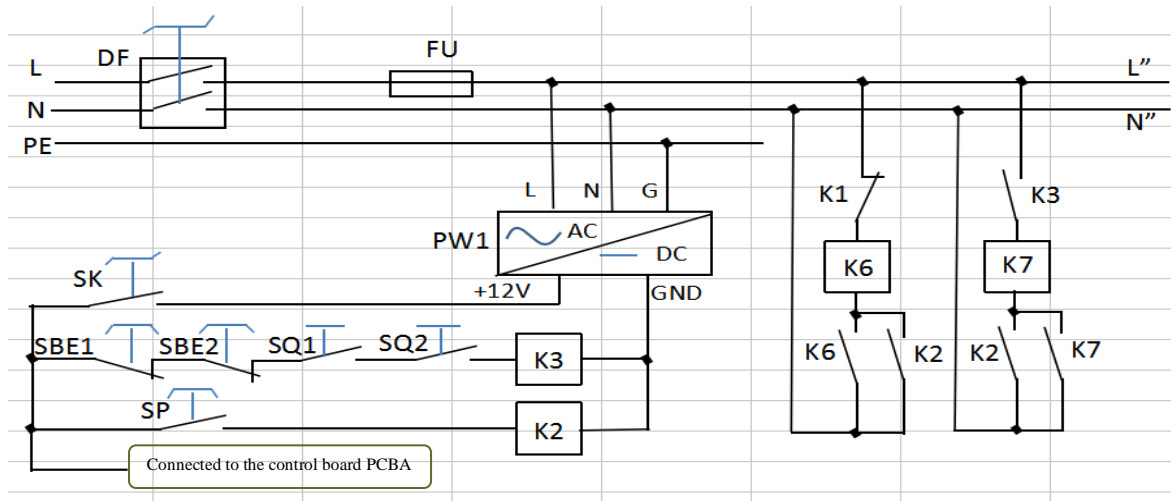

DF in this figure is the air switch, which will strip for protection in the case of overcurrent or short circuit. FU is the fuse, which is located in the same protective circuit as the air switch and used for dual protection. PW1 is the power supply, which is used for supplying the DC 12V power. If the key switch SK is in the ON position, the emergency stop buttons SBE1 and SBE2 are not pressed and the micro switches SQ1 and SQ2 are against the tightened doors, K3 will be closed. If the start button SP is pressed, K2 will be

closed, resulting in closing of the contactor K6. The normally contact of K6 is used for self-protection. Once K1 is not closed, K6 will keep the self-protection. Thus, the startup is completed.

If K3 and K2 are closed, K7 will be closed for self-protection. Once K3 is not disconnected, K7 will keep self-protection.

If the key switch SK is in the OFF position, the positive level will be changed into the negative level signal, which will be transmitted to the control board PCBA for shutdown. Then the shutdown with delay will be finished by the control board PCBA. If IPC is normally shut down (with delay), K1 will be closed for a short time, controlled by the control board PCBA. Thus, the equipment will be shut down. As shown in the figure, K7 is indirectly controlled by the emergency stop buttons SBE1 and SBE2 and micro switches SQ1 and SQ2 through K3.

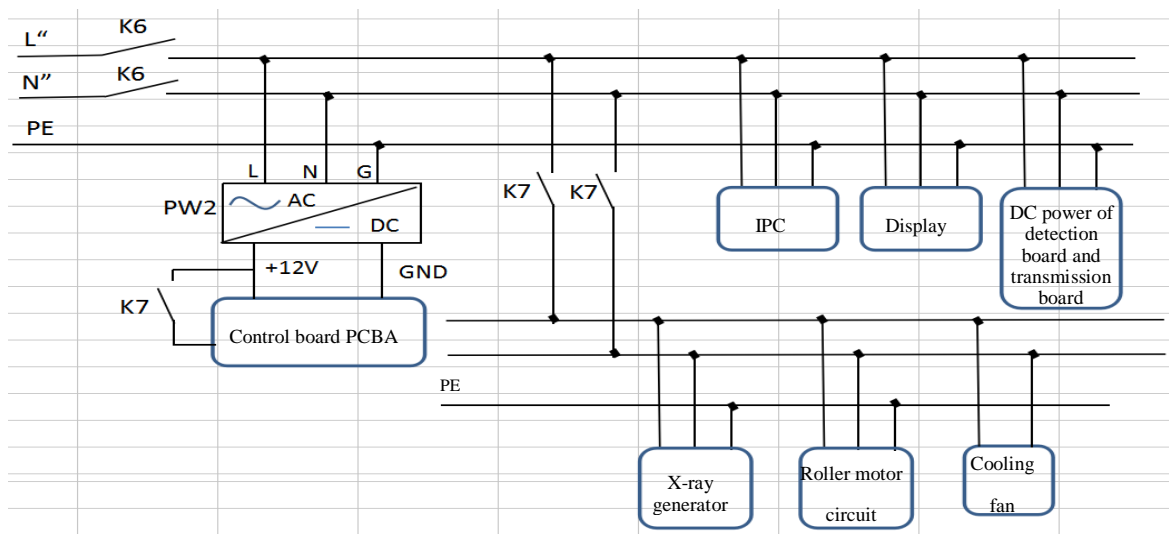

If K6 is closed, its two normally contacts will be connected to connect another switching power supply PW2, thus powering on the control board PCBA, display, IPC and detection/transmission board switch.

If K7 is closed, the X-ray generator, roller motor control circuit and cooling fan will be powered on. Thus, all the electrical appliances are powered on!

As K7 is indirectly controlled by the emergency stop buttons SBE1 and SBE2 and micro switches SQ1 and SQ2, the X-ray generator, roller motor circuit and cooling fan are also indirectly controlled by the emergency stop buttons SBE1 and SBE2 and micro switches SQ1 and SQ2. One normally open contact of K7 can be connected between the +12V power supply and control board PCBA, as an action signal for testing of the emergency stop buttons and micro switches.

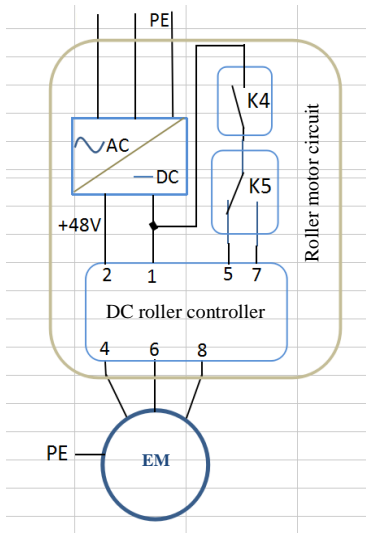

Fig. 4-1

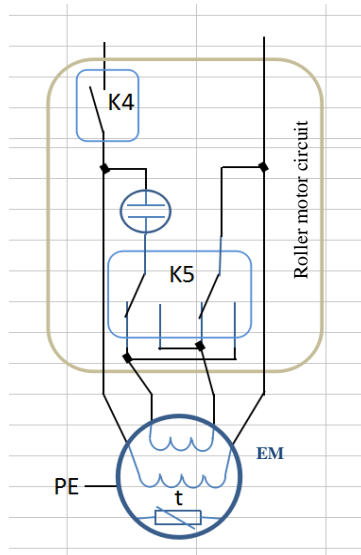
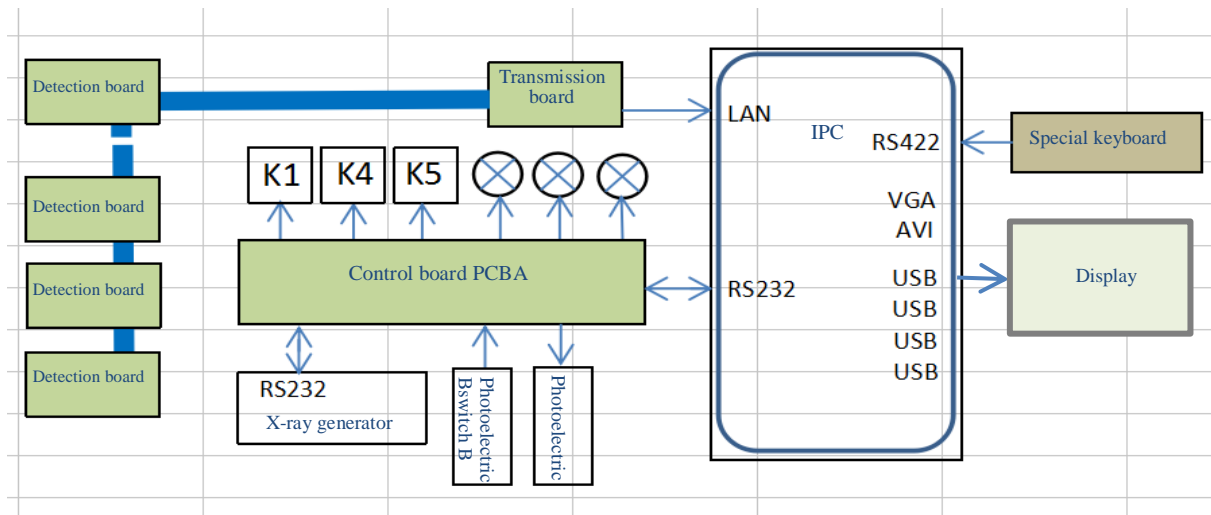

Fig. 4-2

Two kinds of roller motor circuit are available. Normally, the circuit shown in Fig. 4-1 is applicable to the model 5030, where the DC roller motor controller is provided in the 48V DC switching power supply, the startup of the motor EM is controlled by the relay K4 and the forward/back running by the relay K5. The circuit in Fig. 4-2 is applicable to other models, in which only one capacitor is used, the startup of the motor EM is controlled by the relay K4 and the forward/back running by the relay K5.



In this figure, the control board PCBA is used for controlling the relays K1, K4 and K5, power indicator, X-ray indicator, alarm indicator, and controlling and receiving the feedback information of the X-ray generator. It is also used for controlling "Photoelectric A", receiving the information of "Photoelectric B", and transmitting information to the upper computer (IPC) through the RS232 interface.

IPC is equipped with rich interfaces, including the RS232 interface connected to the control board, interface for the special keyboard (optional) and RS422 interface. It is able to receive the detection information from the "Detection Board" (bag inspection image sensor) through the "Transmission Board" and LAN port. Such information will be processed into images, which will be shown on the display connected through the VGA or AVI interface.

5. Maintenance

5.1 Dust Removal

Preferably, the dust on the equipment surface should be cleaned once a day by wiping with soft cloth (Fig. 5-1), in order to keep the equipment always clean. The power supply should be cut off before wiping, to ensure the safety! Maintenance should be carried out promptly after some time to ensure long-term normal operation. Dust is produced inside the equipment after operation for some time. It is recommended to clean the inside once every six months, and replace the dust screen of the fan by removing it by hand (Fig. 5-2, 5-3 and 5-4) and installing a new one. (The cleaning interval can be adjusted, depending on the site environment). Dust should be purged with the “blower gun” (Fig. 5-5) or “electric blower gun”. The triangular key and tool kit required for removal of the equipment cover are, free of charge, included in the standard configuration (Fig. 5-6 and 5-7).

Before the “blower gun” is used, an appropriate “steam-water separation” device should be provided in the air pipe, to prevent water drops. The circuit boards and terminals should be wiped with a clean soft brush (Fig. 5-8) before purging with the “blower gun”. The photoelectric switch hole should also be cleaned, to ensure the smoothness of the infrared ray path (Fig. 5-9). Priority should be given to the safety. That is, the power supply must be cut off before internal cleaning.

Equipment Maintenance Schedule:

1	Overall cleaning	Twice a year
2	Cleaning of photoelectric switch and through hole	Twice a year
3	Replacement of dust screen of cooling fan	Twice a year
4	Replacement of cooling fan	Once per 10000h
5	Fastening of equipment screws	Once a year
6	Replacement of lead curtain	Once per 10000h
7	Replacement of conveyor belt	Once per 20000h
8	Replacement of supporting roller	Once per 20000h
9	Replacement of driven roller	Once per 20000h
10	Replacement of roller motor	Once per 30000h
11	Replacement of X-ray generator	Once per 30000h
12	Replacement of IPC mother board	Once per 20000h
13	Replacement of IPC hard disk	Once per 30000h
14	Replacement of contactor	Once per 30000h
15	Replacement of relay	Once per 30000h
16	Replacement of switching power supply	Once per 30000h
17	Replacement of air switch	Once per 30000h
18	Replacement of detection board/transmission board	Once per 30000h
19	Replacement of photoelectric switch	Once per 20000h
20	Replacement of indicator	Once per 30000h
21	Replacement of emergency stop and stop button	Once per 30000h



Fig. 5-1



Fig. 5-2



Fig. 5-3

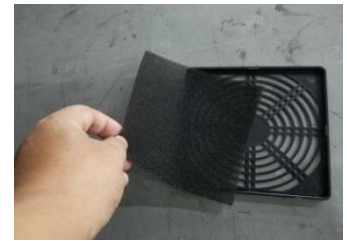

Fig. 5-4



Fig. 5-5



Fig. 5-6



Fig. 5-7



Fig. 5-8



Fig. 5-9

5.2 Component Replacement

Two kinds of fan are applied in the equipment. Preferably, the five fans in total, including two chassis-mounted fans for cooling the whole equipment, one fan for cooling IPC and two fans for cooling the X-ray generator, should be replaced at the same time. Three DC 12V output terminals are provided on the switching power supply, Q12 for the weak-current control circuit, W12 for the special control board and V12 for the detection board and transmission board. IPC is equipped with one power adapter. The model 5030 is normally provided with one switching power supply for DC 48V output, which should be replaced at the same time. It is recommended to replace the five relays and two contactors respectively at the same time. The detection board and transmission board should be replaced by our technicians. The recommended periods of component replacement are listed in the "Equipment Maintenance Schedule" and the replacement steps of general components are described in "Component Replacement", with corresponding pictures. **The power supply must be cut off before component replacement, in order to ensure the safety!**

ZKTECO CO., LTD.

ZK Building, Wuhe Ave, Bantian, Longgang District, Shenzhen, China.

188 Industrial Avenue No. 26, Tangxia, Dongguan, Guangdong, China.



www.zkteco.com