

# Installation Guide

---

Comet Series Speed Gate

**Applicable Model(s):** Comet-S1000, Comet-S1200

Version: 1.1

# Revision History

| Revision | Date       | Author      | Reviewer | Description  |
|----------|------------|-------------|----------|--|
| V1.0     | 08/09/2023 | Yang Kaijin |          | Original Document  |
| V1.1     | 02/23/2024 | Yang Kaijin |          | The appearance of the device and wiring diagram have been changed. |

# 1 Installation Requirements

1. It is recommended that the device be installed on a level and solid floor. If the floor is uneven or not strong enough to hold the device in place, resurface the floor or use a pedestal mount to alleviate the change problem.
2. Do not use the device outdoors or in wet, corrosive conditions where rain, moisture, or corrosive materials could damage it. Only use it if the device is specifically rated as waterproof.
3. Make sure the device's grounding wire is securely connected. Differentiate between high and low voltage power setups to prevent potential harm to personal safety and unforeseen incidents.
4. After installation, check the grounding wire, connectors, junctions of the connecting line, and moving parts to ensure they are securely connected. Promptly tighten any loose nuts, screws, or fasteners to prevent long-term gate failure.

# 2 Installation Environment

Refer to the provided figure to identify the installation position based on the device's size and space requirements. When installing against a wall, leave a 100mm space to allow for opening the top cover during commissioning and maintenance. Maintain a 100mm distance between two devices if multiple channels are present. This guide take the Comet-S1000 as an example for installation instructions.

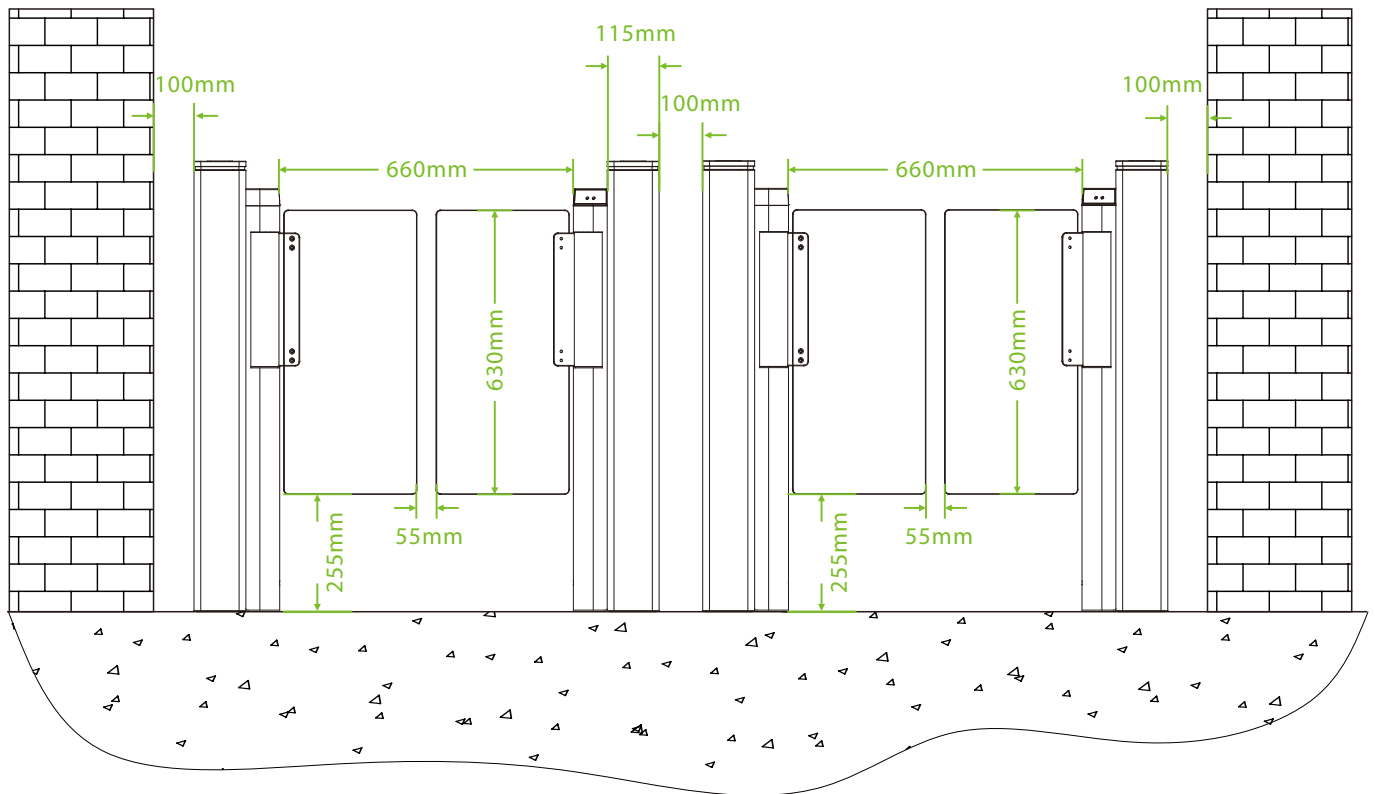

### 3 Preparation

Before installing the device, make sure that you have the following items:

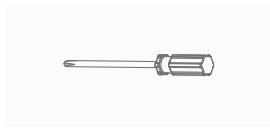

Screwdriver



Pencil



Electric Drill

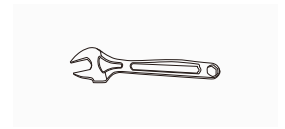

Wrench



Hex Wrench

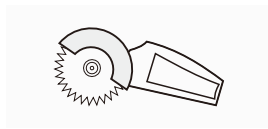

Cutting Machine



Hammer



Tapeline

**Note:** Except for the hex wrench, all other tools should be provided by you.

### 4 Installation

1. After checking the list to ensure all devices and items are correct, transport the device to its installation location.

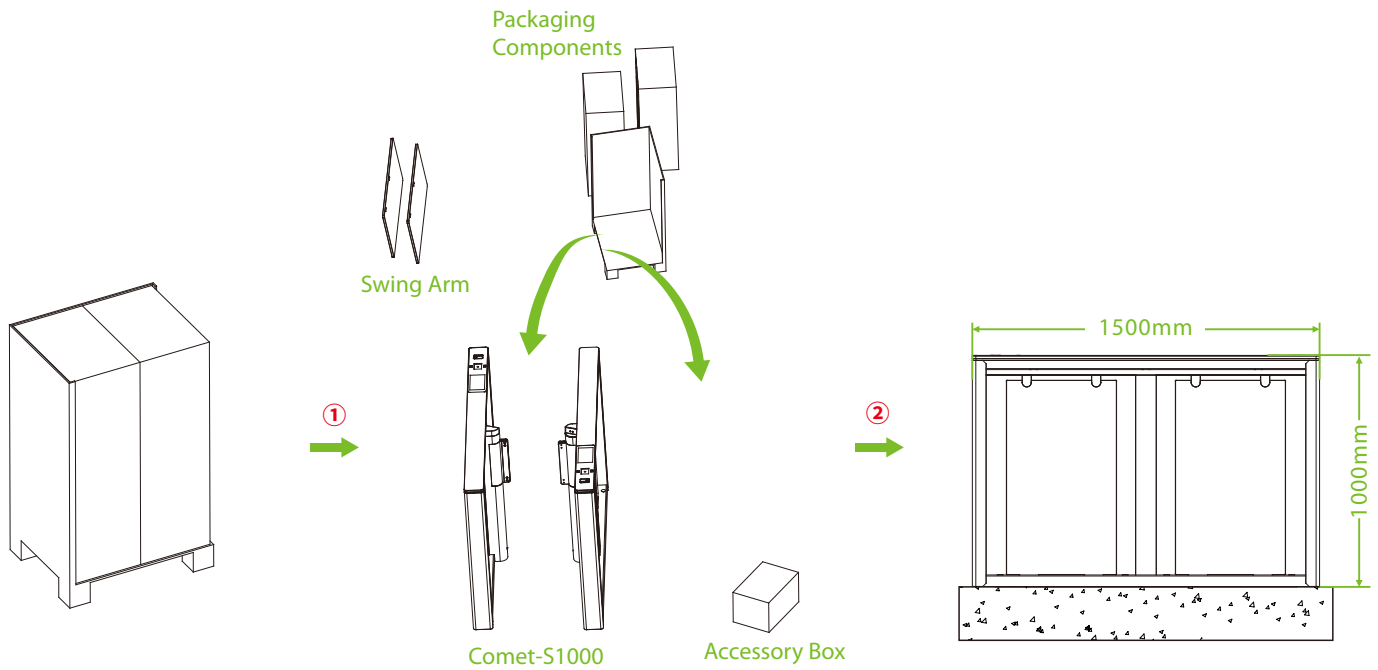

2. Remove the two screws hidden under the top lid, then open and flip the top lid of the device (Same for the slave).

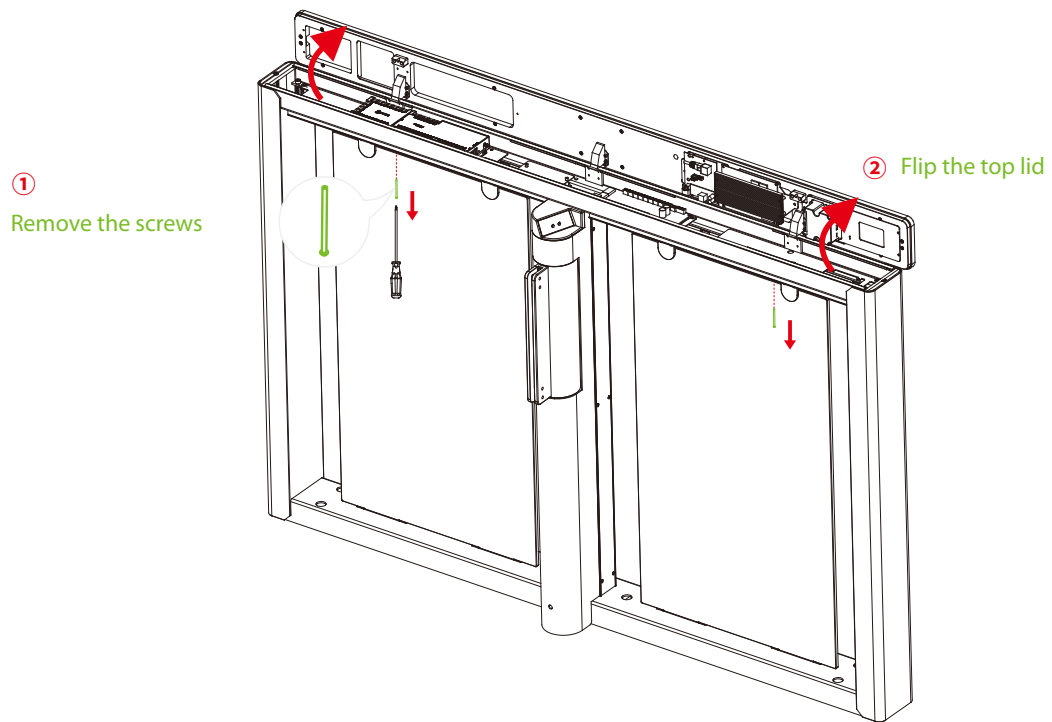

3. Remove the mounting rail from the device (Same for the slave).

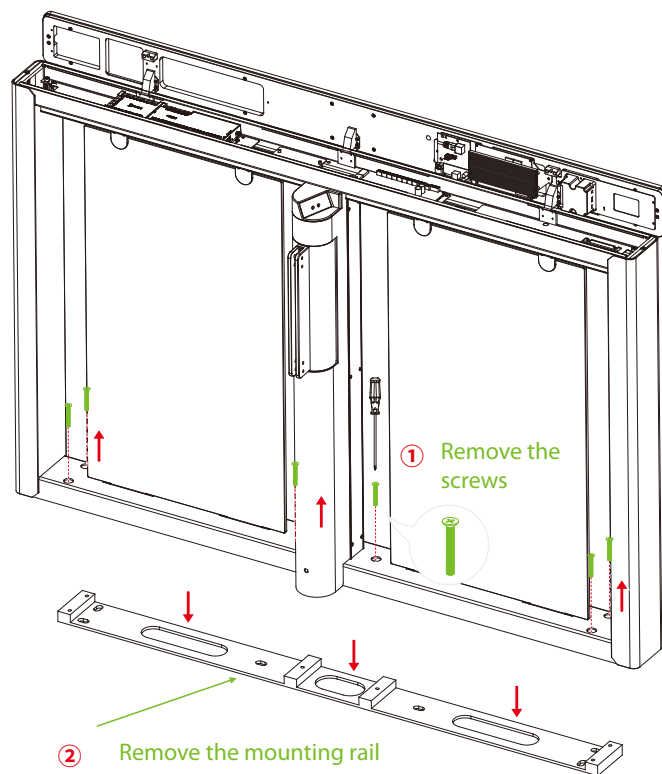

4. Remove the master's power supply cover.

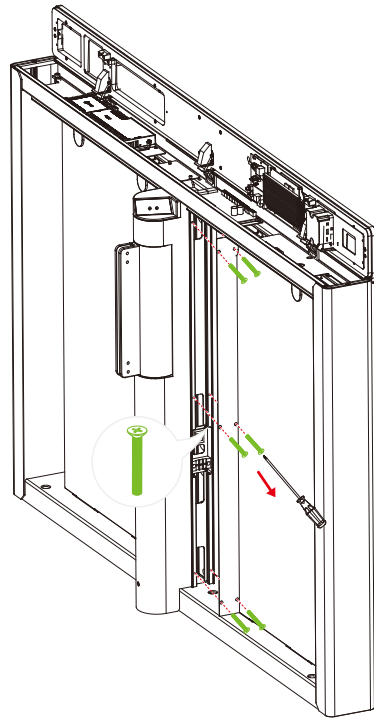

5. Carry the mounting rail to the location where it will be mounted.

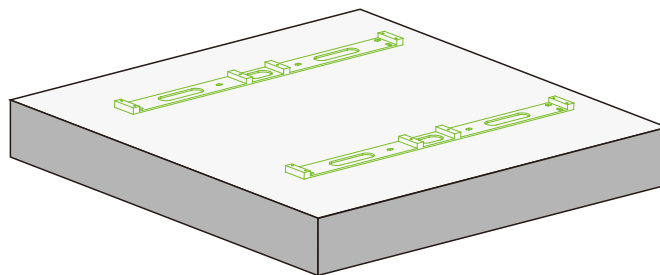

6. Use a pencil to mark down the screw holes, wire holes, and conduits of the mounting rail.

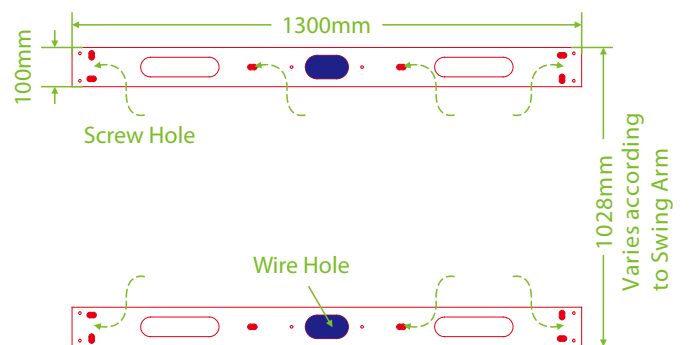
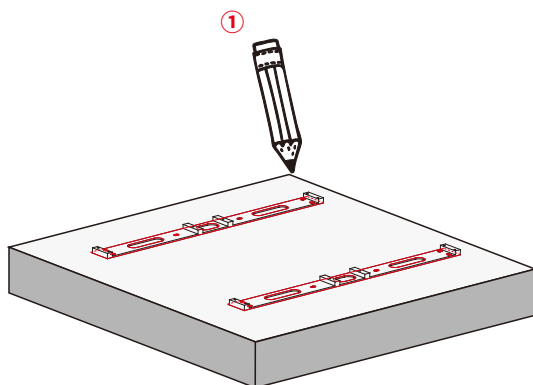

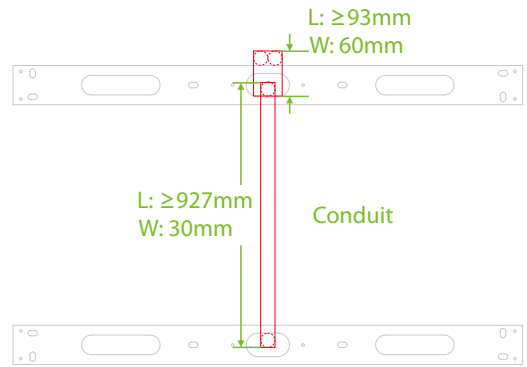
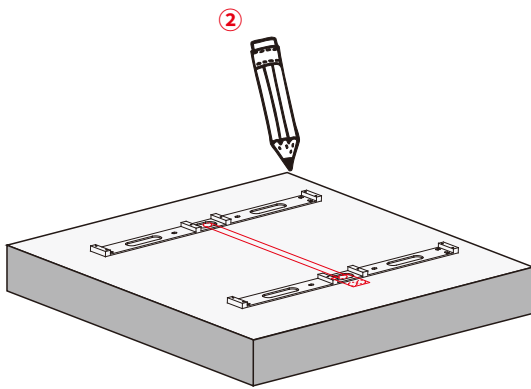

**Note:** For device safety and future maintenance, when installing, encase the power cable, network cable, and tether cable within a PVC pipe with a 20mm diameter. The conduit diameter should exceed 20mm; this guide recommends using a 30mm diameter as an example.

- Take out the mounting rail and use an electric drill to create 12 holes based on the markings.

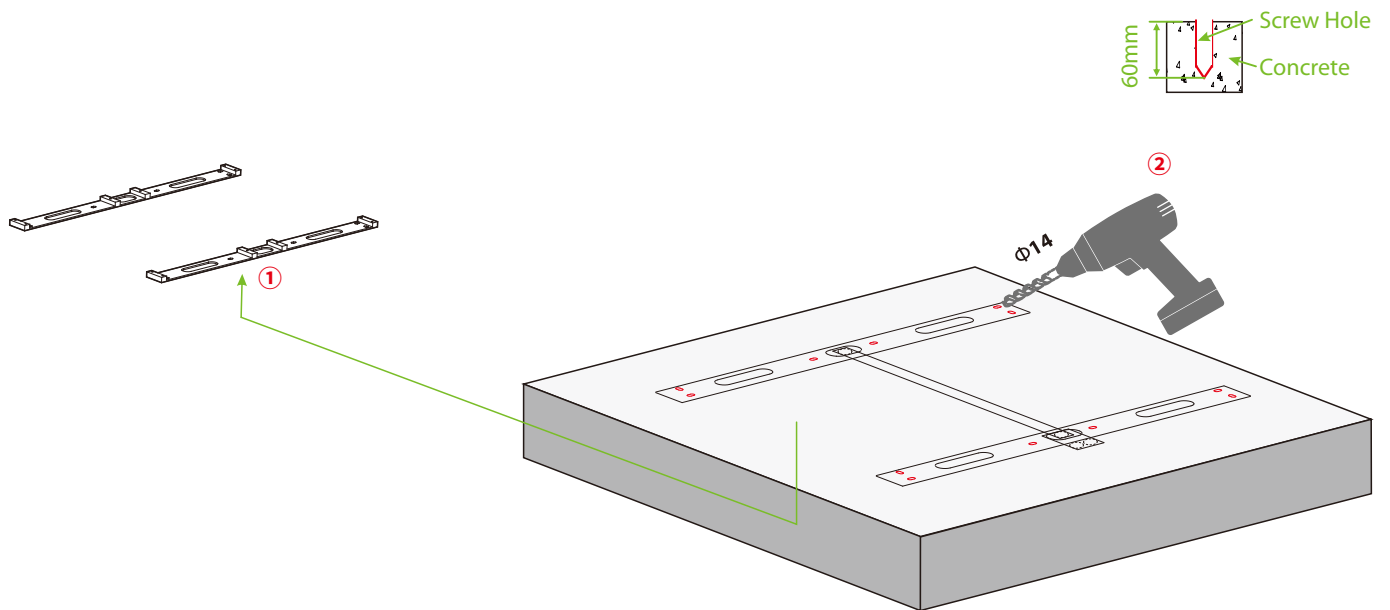

8. Use a cutting machine to create two conduits on the ground according to the marking of the mounting rail. One conduit should have a length greater than or equal to 93mm, a width of 60mm, and a depth of 100mm. The other conduit should have a length greater than or equal to 927mm, a width of 30mm, and a depth of 100mm.

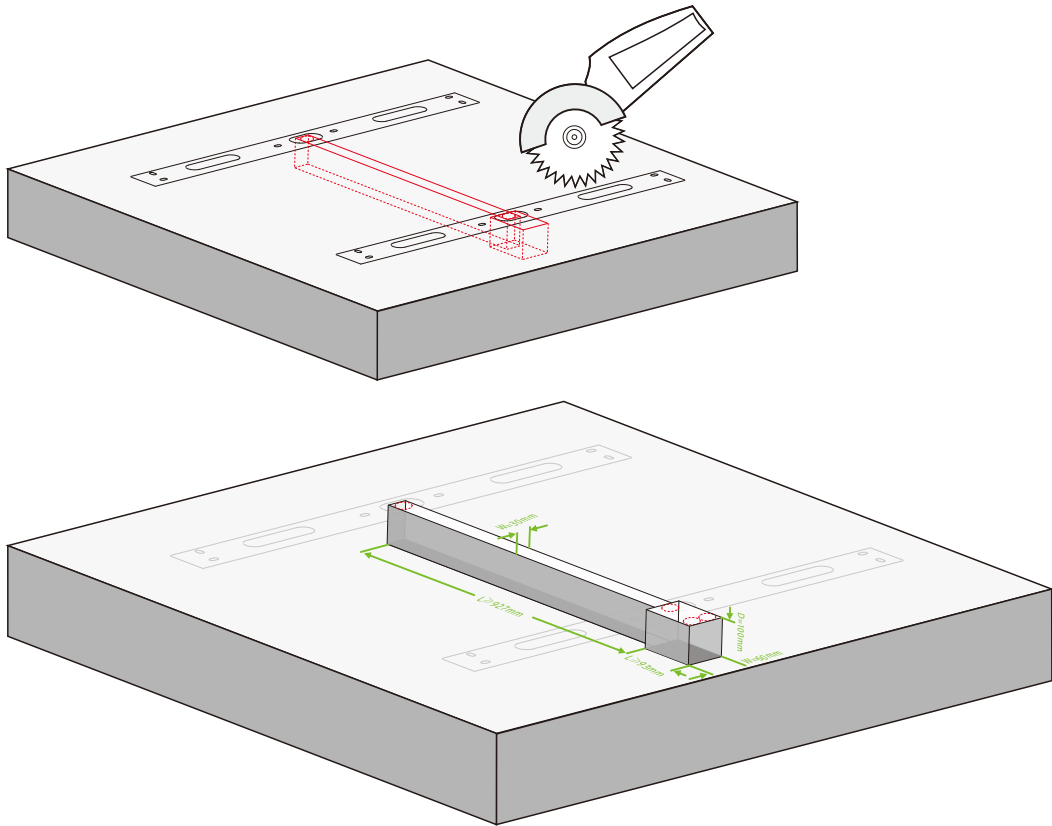

9. After drilling, clean up debris and dust.

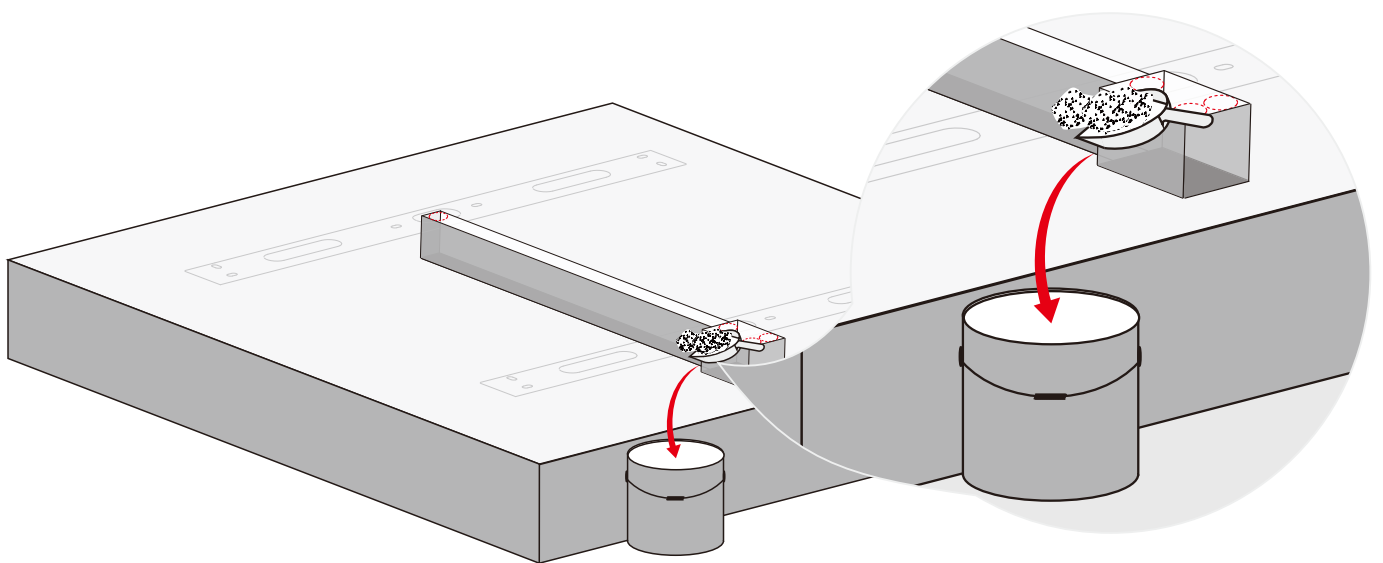



10. Reposition the mounting rail at the installation site and verify if the drilled holes and conduits align with the marks on the mounting rail.

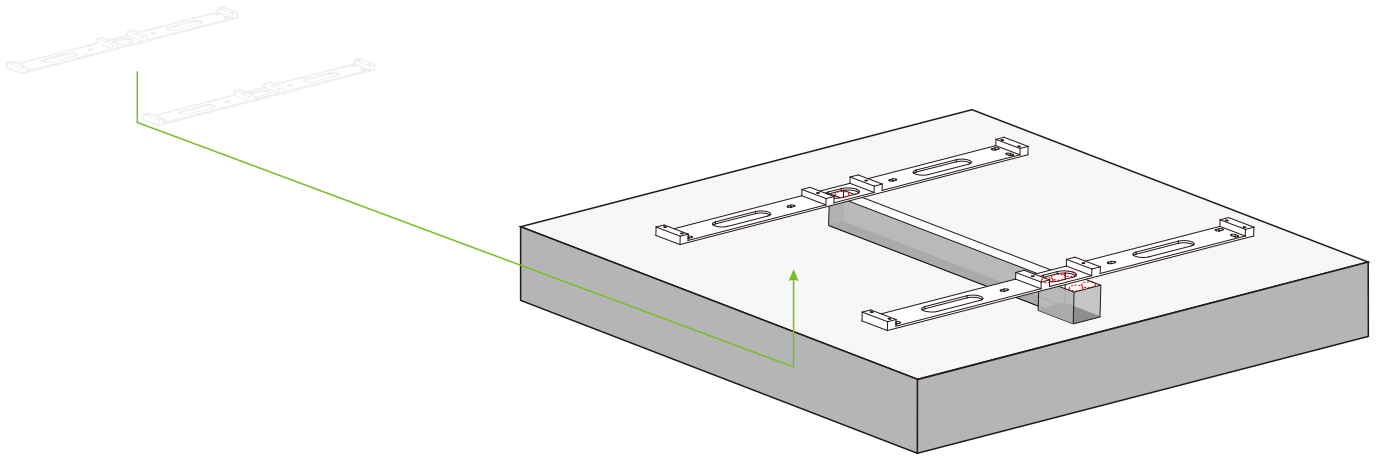

11. Place the 20mm diameter PVC pipe into the conduit.

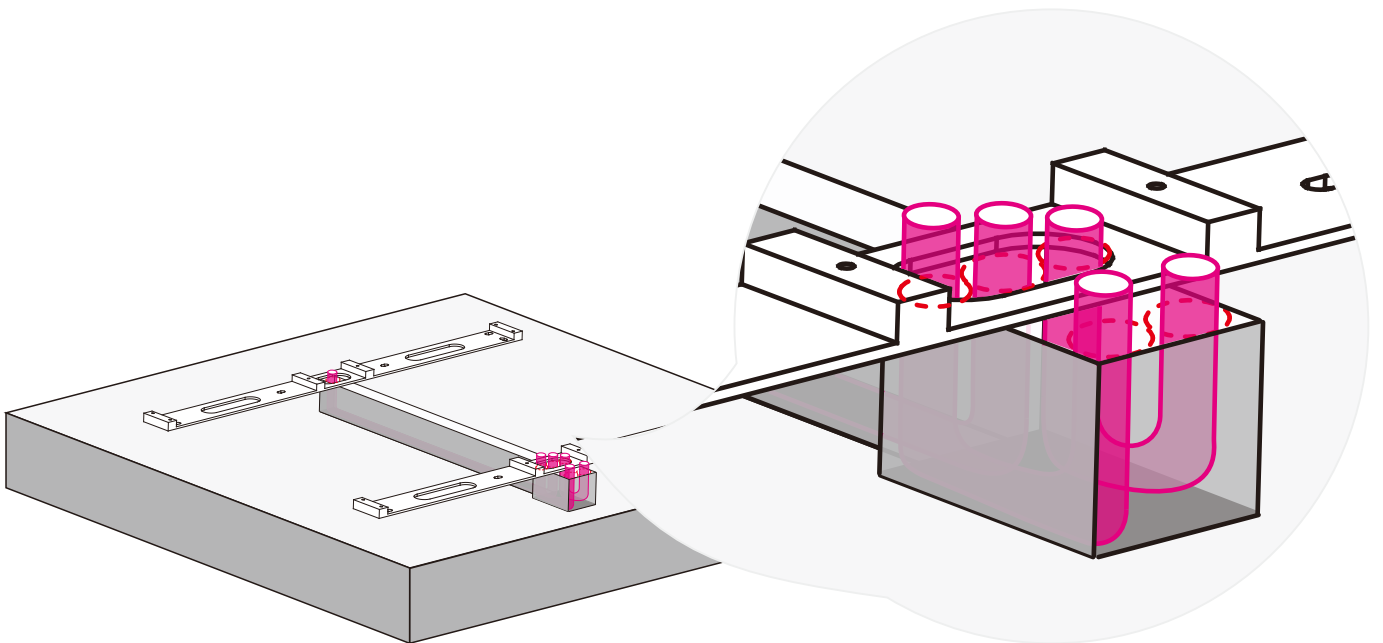

12. Insert the power cable and ethernet cable into the PVC pipe to connect the power supply and access controller.

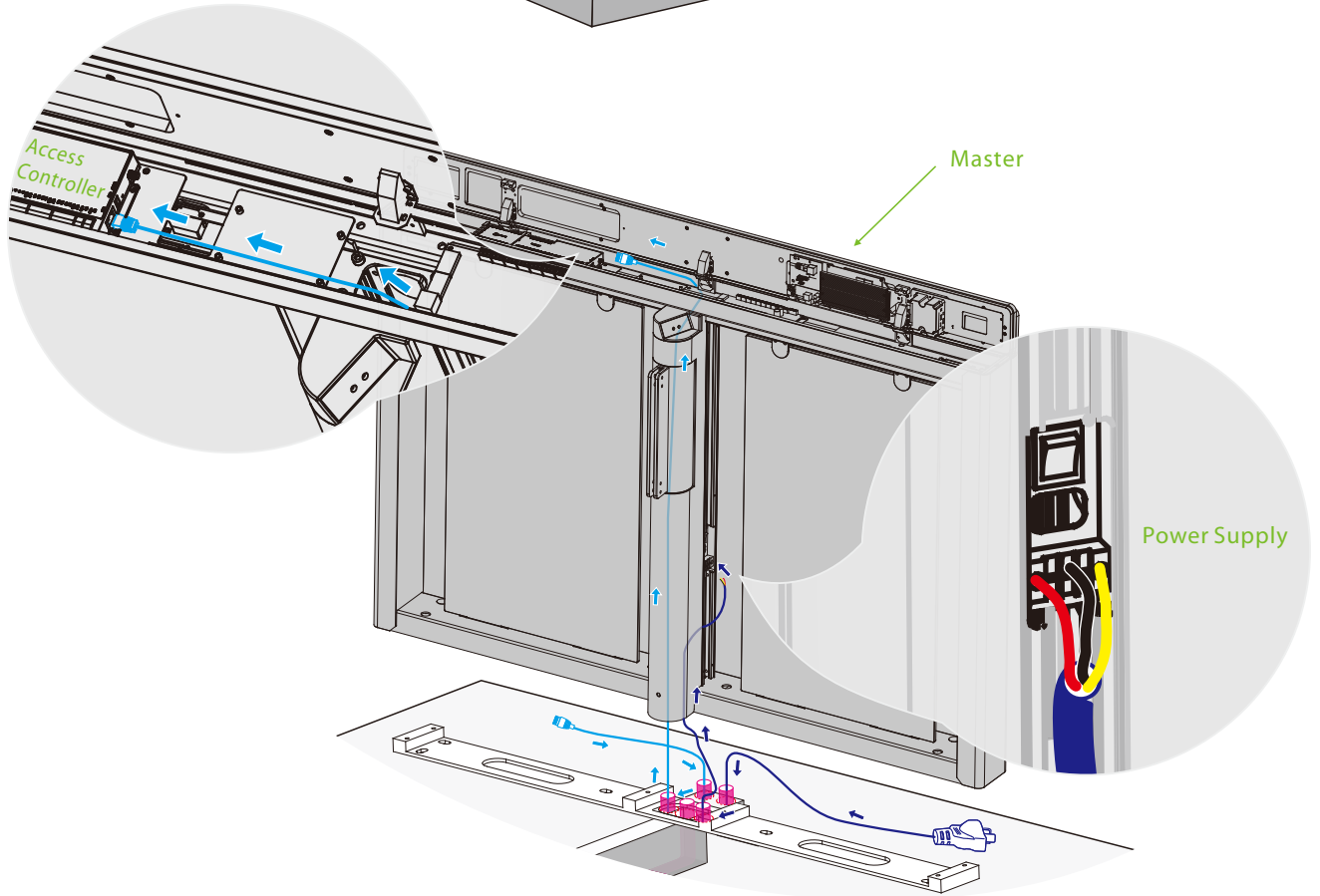
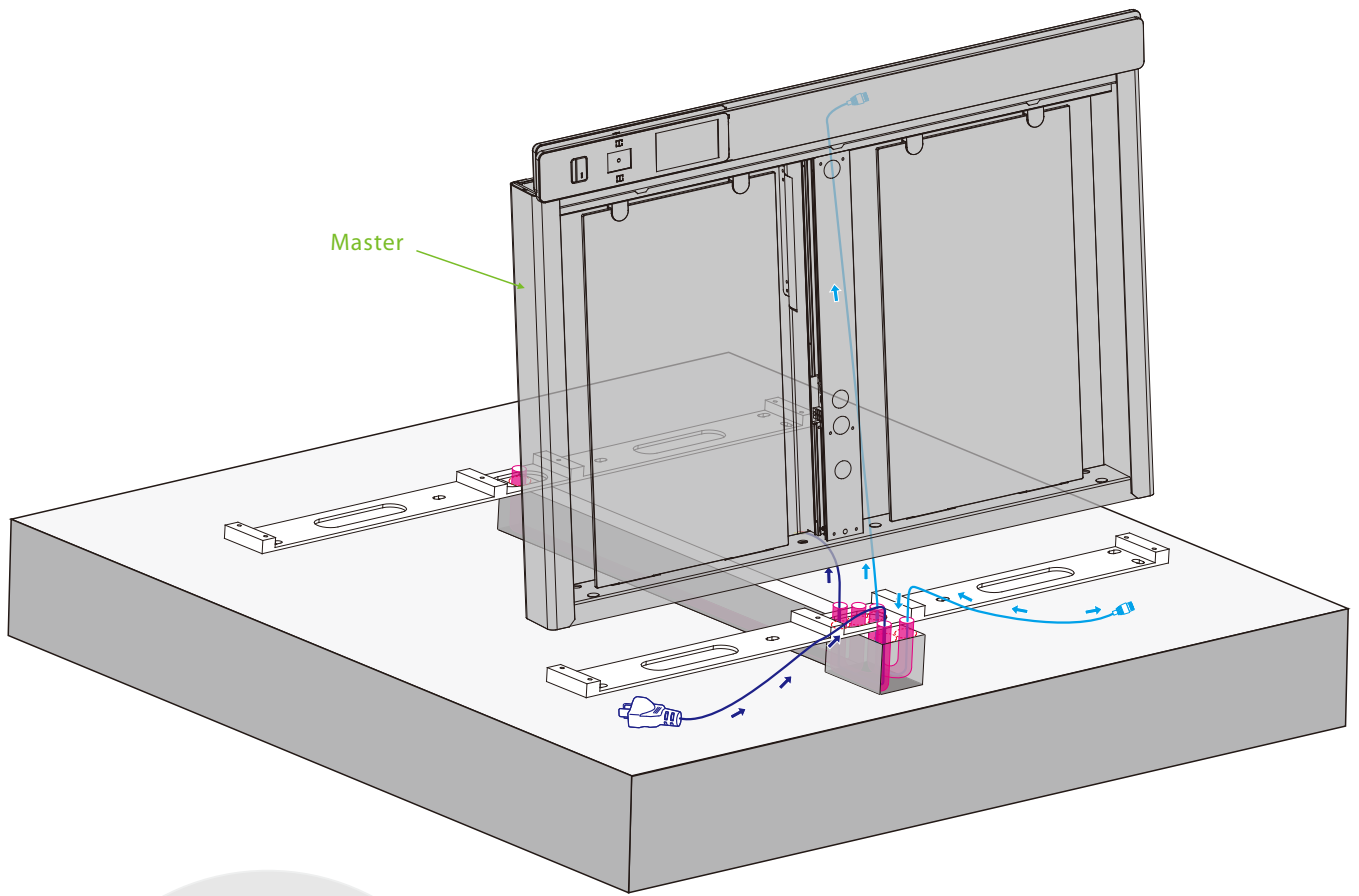

13. Pull the tether cable out of the master, insert it through the PVC pipe buried in the conduit, and connect it to the Slave. Then, turn on the power switch to test if the device is working properly. The tether cable consists of three cables that connect to the master and slave turnstile control boards, the master and slave motor drive, and the light control board. Please refer to the wiring diagram for detailed wiring instructions.

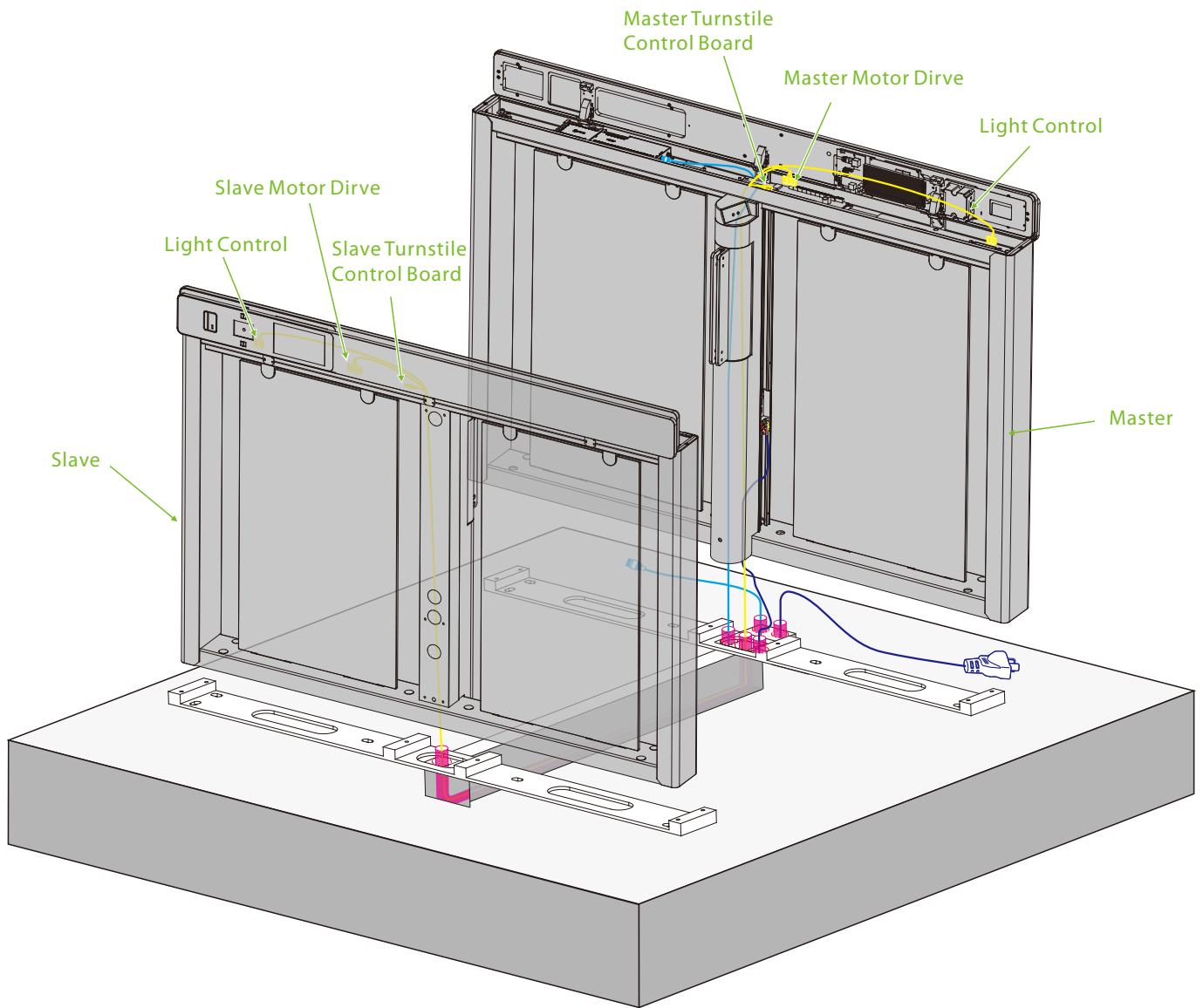

**Note:**

- 1). Separate the high and low voltage power lines during installation.
- 2). After completing the test, disconnect the device's power supply, and avoid operating the device with electricity.
- 3). The conduit depth should be at least 100mm, and the height of the exposed PVC pipe above the ground should be more than 100mm. Make sure the exit bends back to prevent water from entering the conduit.

14. If all functions of the device are normal, disconnect the power supply, then insert the bolts and secure them with a hammer. Finally, insert the washers and nuts and tighten with a wrench to secure the mounting rails.

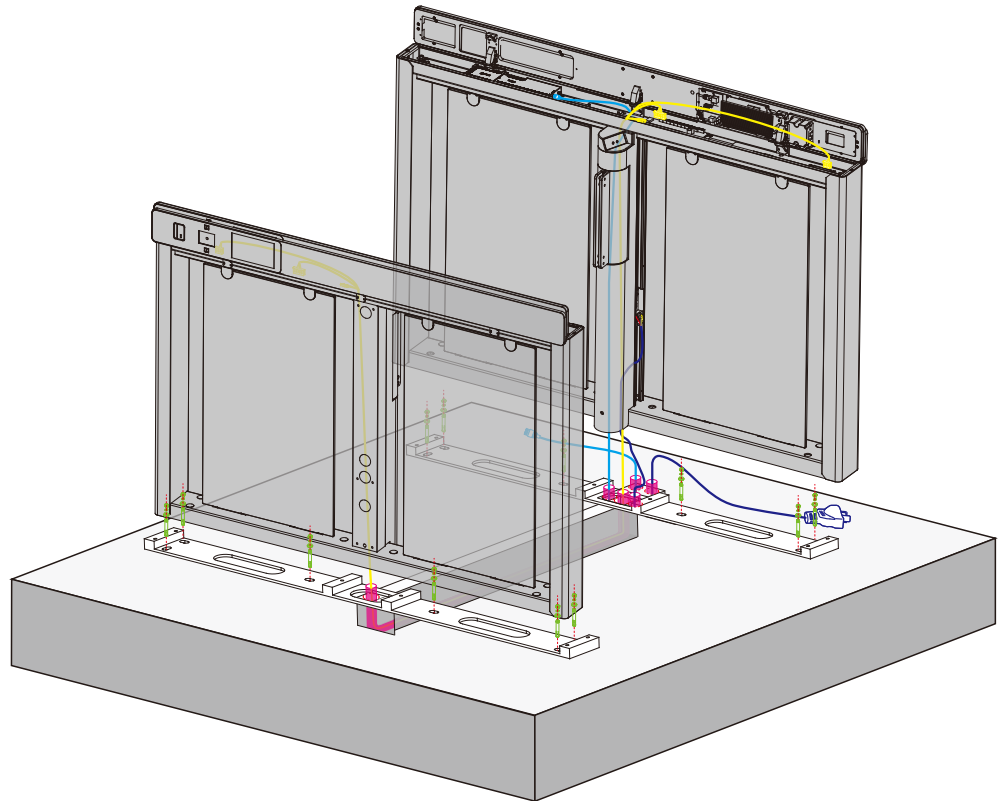
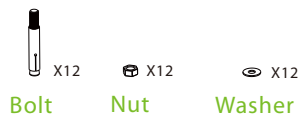

15. Pour the concrete to fill the conduit

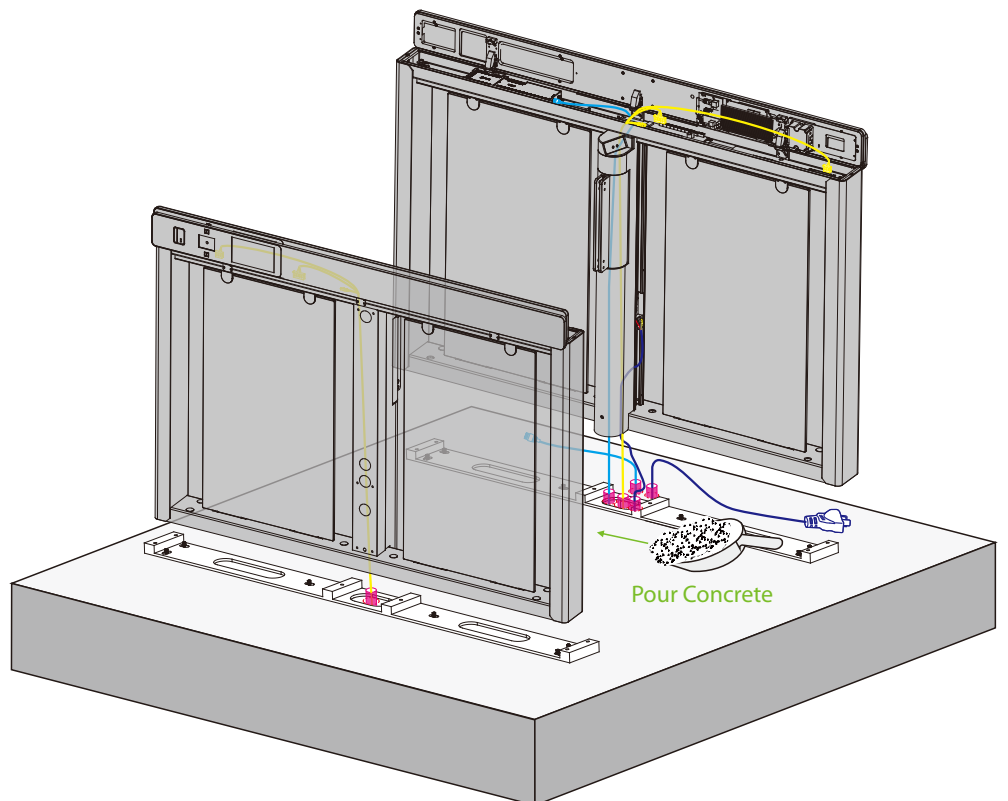

16. Secure the master and slave to the mounting rails separately.

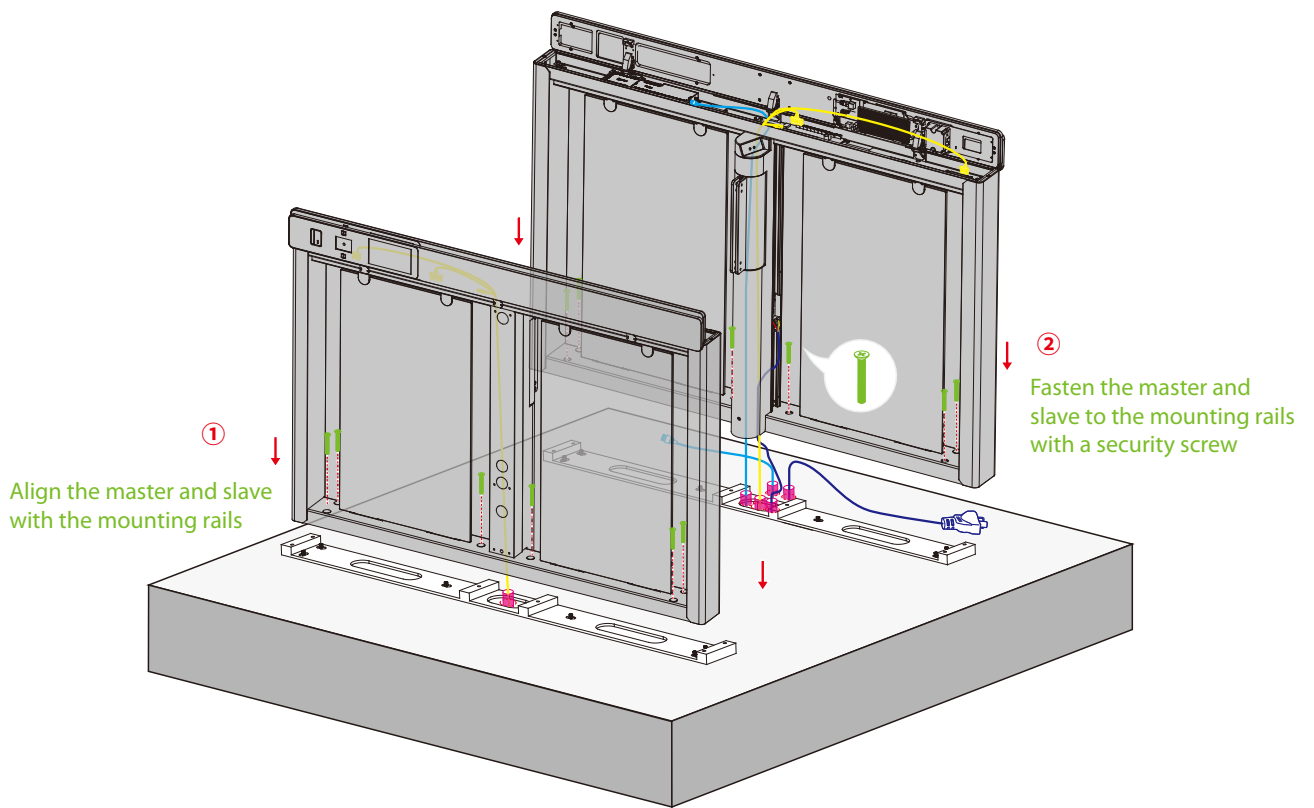

17. Close the top lid, and secure it with screws (Same for the Slave).

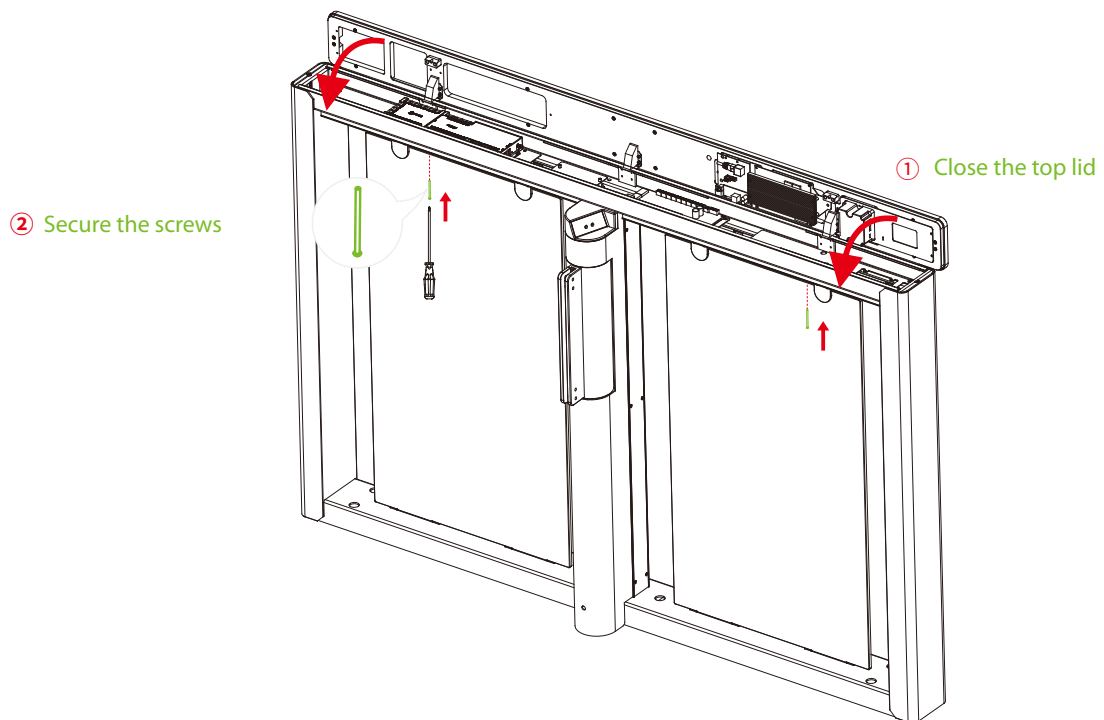

18. Close the master's power supply cover.

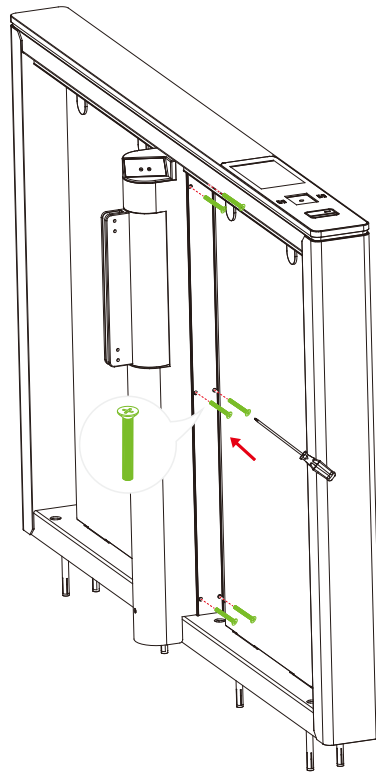

19. Assemble the swing arm by yourself. Refer to the diagram below for installation instructions. (Same for the Slave)

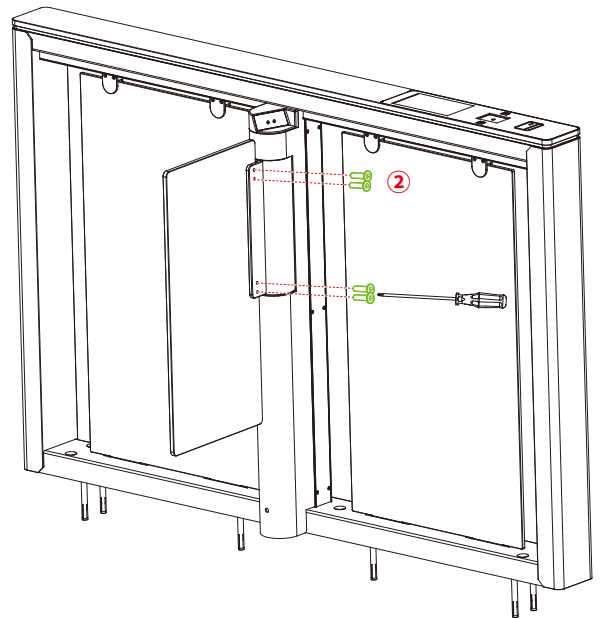
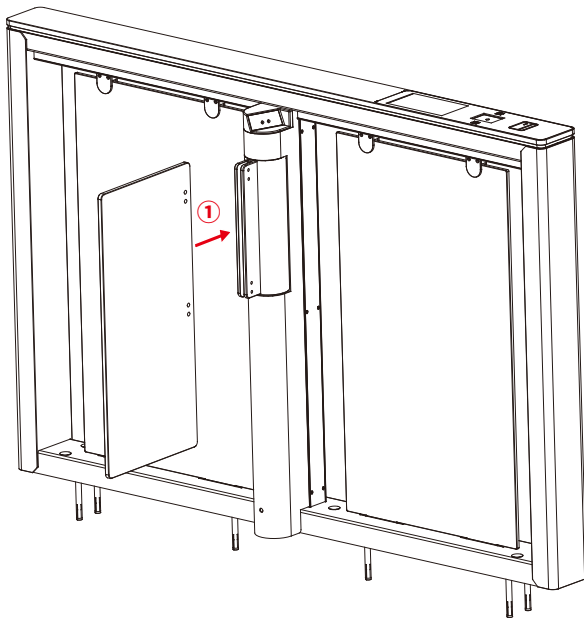

20. Cover the master and slave with dust plugs.

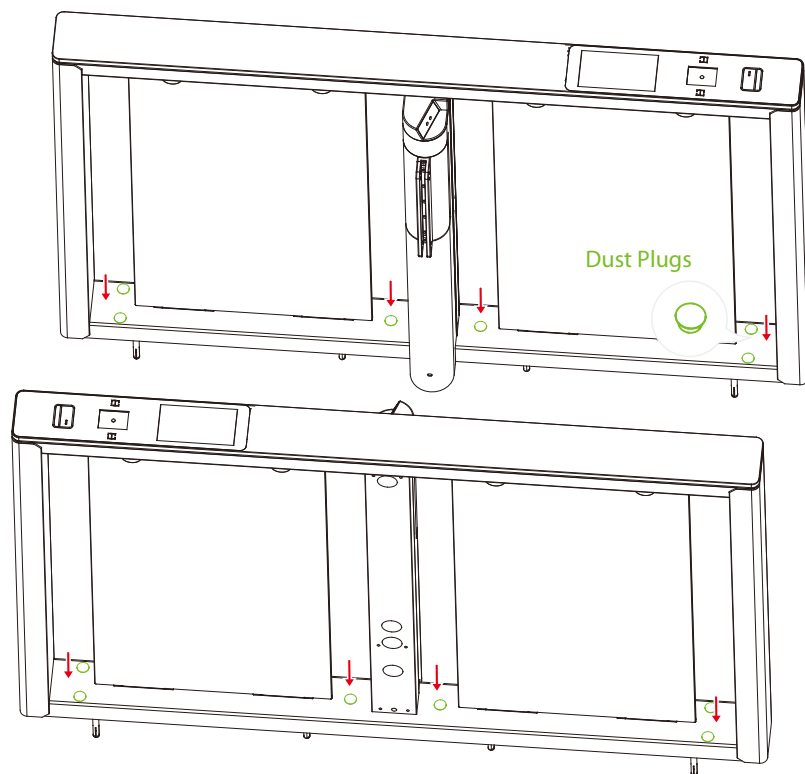

21. We suggest marking a warning line on the floor to remind the user, when installation is being completed. It reminds the user to wait outside the warning line until the previous user have completed the verification process and passed through the turnstile.

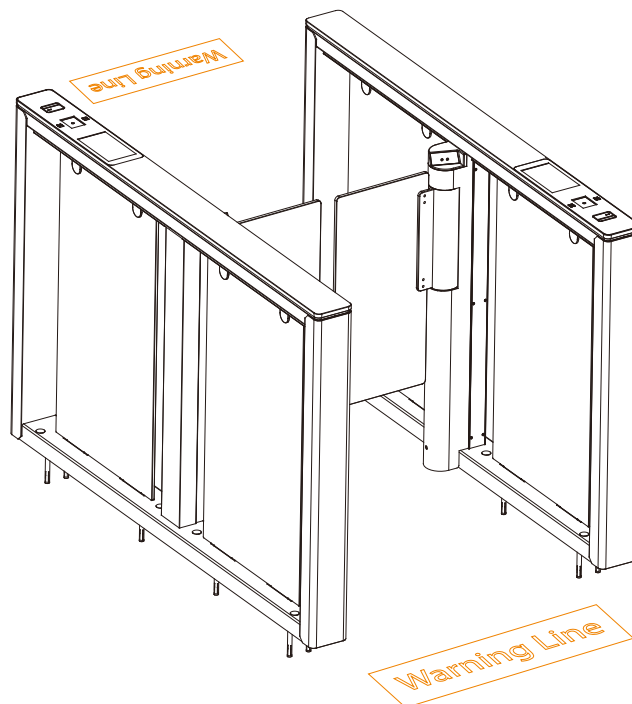

# 5 Wiring Diagram

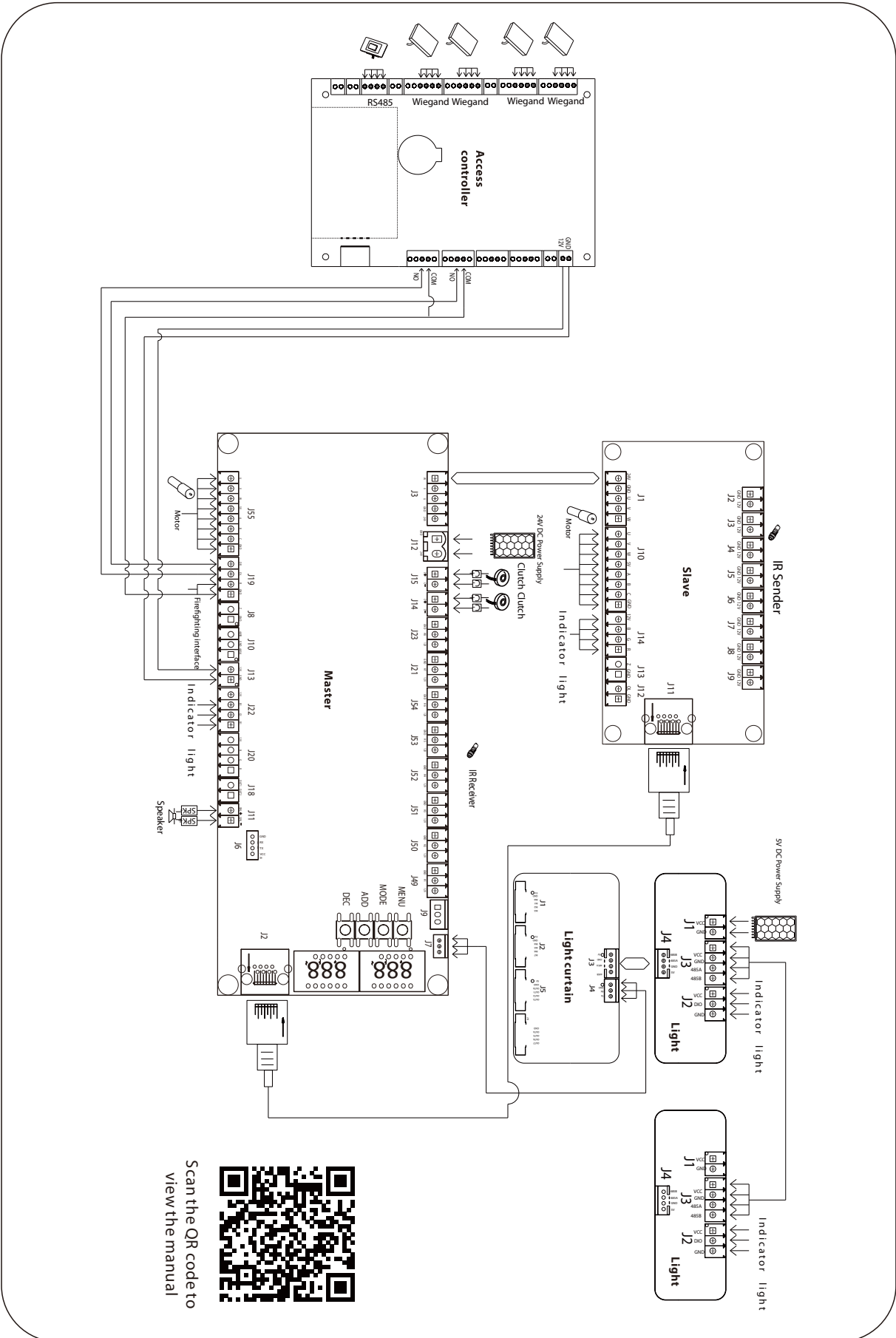

Scan the QR code to view the manual





ZKTeco Industrial Park, No. 32, Industrial Road,

Tangxia Town, Dongguan, China.

Phone : +86 769 - 82109991

Fax : +86 755 - 89602394

[www.zkteco.com](http://www.zkteco.com)

