

36.5°C (97.7°F)

# SBTL8033

Touchless Entrance Control Solution  
with Body Temperature Measurement



The novel coronavirus has given rise to grave concerns about the public health and personal hygiene because of its wide geographical spread.

It has been proven that most of the germs spread through our hands. Thus, a contactless entrance control solution effectively reduces the risk of infection spreading in your premises and public areas.

## Masked Face

During this global pandemic issue, wearing surgical masks is a must-take precaution before entering crowded areas such as offices, shopping malls, stations and so on. Un-masked persons would potentially be seen as spreading germs in the community as droplets are one of the most dangerous and easiest ways of infection spreading. With the help of Computer Vision technology, ZKTeco's upgraded terminals can identify whether the user is wearing a mask, while recognizing faces rapidly and accurately.



## Body Temperature Detection

Most of the thermal cameras in the market are designed for industrial use. Such temperature detections may have up to +/-2 degrees of deviation, which is simply not precise enough for human body temperature screening for pandemic diseases.

In order to solve this problem, ZKTeco combines the visible light facial recognition technology with infrared temperature detection to provide accurate and fast temperature screening during identity verification.

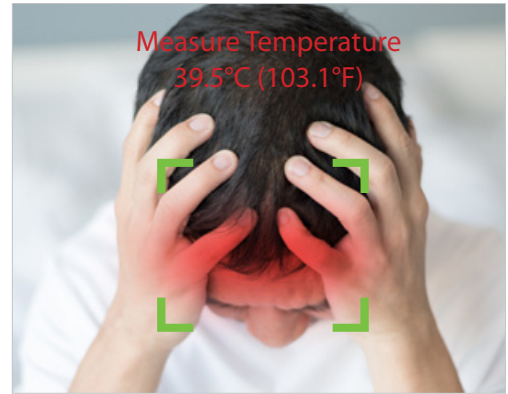

## Quality

The casing of the product is mostly made of superior SUS304 stainless steel for its remarkably high durability. The barrier panels are made of acrylic and have better aging resistance and impact resistance. From raw material procurement to production, a strict quality control and inspection system is adapted.



## Features

- Fast and accurate visible light facial recognition with wide angle tolerance for masked individuals
- Body temperature detection
- Instant facial recognition in 0.3s
- Servomotor - faster gate opening speed
- 10 pairs of infrared sensors for stronger tailgate detection
- SUS304 stainless casing
- Higher durability for longer product life cycle
- Bi-directional operation control
- LED passage indicator along the lane
- Convenient installation and maintenance
- Various optional panels
- Emergency mode allows free access in case of power failures or emergency

# Specifications

Power Requirements	AC 100 ~ 120V/200 ~ 240V, 50/60Hz
Operating Temperature	-28°C ~ 60°C (-18.4°F ~ 140°F)
Operating Humidity	20% - 95% (Non-condensing)
Working Environment	Indoor
Max. Speed of Throughput	40 people per minute
Lane Width (mm)	660
Dimensions (L*W*H)	1600 * 1040 * 1200 (mm)
Packing Dimensions (L*W*H)	1700 * 300 * 1130 (mm)
Net Weight (kg)	130kg
Weight with Packing (kg)	150kg
Cabinet Material	SUS304 Stainless Steel
Lid Material	SUS304 Stainless Steel & Acrylic
Barrier Material	Acrylic
Barrier Movement	Swing
Emergency Mode	Supported
Face Capacity	30,000 (1:N) / 50,000 (Optional)
Compatibility	900 MHz Dual Core Customized CPU
	512MB RAM / 8G Flash
	8" High Brightness (400lux) IPS Touch LCD
	2MP WDR Low Light Camera
Dimensions of Facial Recognition Device (H*L*D)	227 * 143 * 26 (mm)
Facial Recognition Distance of Masked Individuals	3m
Temperature Deviation	±0.3°C (±0.54°F)
Detection Distance	25cm – 50cm
Detection Speed	>0.5s
Posture Angle Tolerance	+/-30 degrees

## Optional Panels

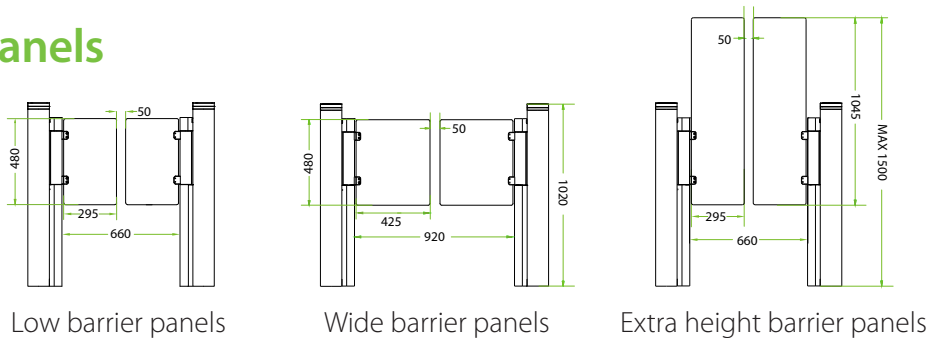

Low barrier panels

Wide barrier panels

Extra height barrier panels

## Dimensions (mm)

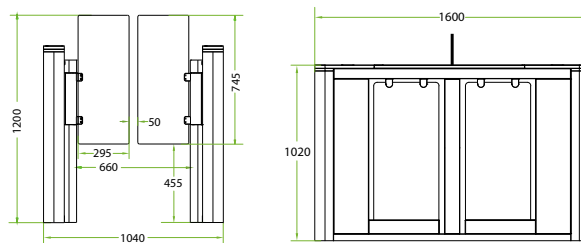

- \* The temperature measurement data is for reference only, and not for any medical purpose.
- \* This product is not suitable for intense light and high-temperature environments.
- \* It is advised to use the product indoor without wind.

