

USER MANUAL

C3-100/200/400

Version: 1.3

Date: sept., 2016

About This Manual

This manual introduces C3-100/200/400 access control panel installation connection and user manual.

Contents

1 Important Security Instructions.....	1
1.1 Important Security Instructions.....	1
1.2 Installation Cautions	3
2 Introduction	5
2.1 System Function Parameters	5
2.2 Product Technical Parameters.....	6
2.3 Control Operator Panel Indicators.....	7
3 Connection and Installation	8
3.1 Case Installation	8
3.2 Installation of Access Control Operator Panel Wires.....	9
3.3 Control Operator Panel System Installation	10
3.4 Control Operator Panel Connection Terminals.....	12
3.5 Connection with Door Sensors, Exit Switches, and Auxiliary Input Devices	15
3.6 Connection with Wiegand Readers	18
3.7 Relay Output Connection	20
3.8 Access Control Operator Panel System Power Supply Structure	22
4 Access Control Operator Panel System Networking	23
4.1 Access Control Networking Wires and Wiring	23
4.2 TCP/IP Network Communication	25
4.3 RS485 Network Communication.....	26
4.4 DIP Switch Setting (485 Address Setting, Factory Setting, and Terminal Resistance Setting).....	27

1 Important Security Instructions

1.1 Important Security Instructions

1. Read, follow and keep instructions: Before operating the equipment, read and follow strictly all security and operation instructions. Please keep the instructions in good condition for future reference.
2. Accessories: Please use the accessories recommended by the manufacturer or delivered with the product. Any other related product is not recommended as the major alarming or monitoring system. The major alarming or monitoring system should comply with the local applicable fire-prevention and security standards.
3. Installation cautions: Do not place this equipment on any unstable table, tripod mount, support or base, lest the equipment should fall and get damaged, and more undesirably cause severe personal injuries. Therefore, it is important to install the equipment as instructed by the manufacturer.
4. All peripheral devices must be grounded.
5. No external connection wires can be exposed. All connections and idle wire ends must be wrapped with insulating tapes to prevent accidental contact with exposed wires from damaging the equipment.
6. Repair: Do not attempt unauthorized repair of the equipment. Disassembly or detachment is likely to cause shock or other risks. All repair jobs should be done by qualified repair personnel.
7. Damages in need of repair: In any of the following cases, first disconnect the AC/DC power supply from the equipment and notify qualified repair personnel for repairs:
 - The power cord or connector is damaged.
 - There is entry of liquid or any other foreign object into the equipment.
 - The equipment is wetted or exposed to bad weather (rain, snow, etc.).

- If the equipment cannot work normally even though operated as instructed, please be sure to adjust only the control components specified in the operation instructions. Incorrect adjustment of other control components may cause damage to the equipment, and add to troubleshooting workload of the qualified technicians.
 - The equipment falls down or its performance changes obviously.
8. Replacing components: If it is necessary to replace a component, the repair personnel must use only the substitutes specified by the manufacturer.
 9. Security inspection: After the equipment is repaired, the repair personnel are supposed to conduct security inspection to ensure the equipment can work normally.
 10. Power supply: Operate the equipment with only the type of power supply indicated on the label. Contact the operator for any uncertainty about the type of power supply.



Violation of any of the following cautions is likely to lead to personal injury or equipment failure, and any resulting damage will not be covered by our routine maintenance.

Before installation, switch off the external circuit (that supplies power to the system), including locks.

- Before connecting the equipment to power supply, ensure the output voltage is within the specified range.
- Never connect power before completion of installation.

1.2 Installation Cautions

1. The conduits of wires under relay must be matched with metaled conduits, other wires can use PVC conduits, to prevent failure caused by rodent damage. Although a control panel is designed with good antistatic, lightning-proof, and leakage-proof functions, ensure its chassis and the AC ground wire are connected properly and the AC ground wire is grounded physically.
2. It is recommended not to plug/unplug connection terminals frequently when the system is energized. Be sure to unplug the connection terminals before starting any relevant welding job.
3. Do not detach or replace any control panel chip without permission, because unprofessional operation may cause damage to the control panel.
4. It is recommended not to connect any other auxiliary devices without permission. All non-routine operations must be communicated to our engineers in advance.
5. A control panel should not share one power socket with any other large-current device.
6. It is preferable to install card readers and buttons at heights of **1.4-1.5m** above the ground, but the heights are subject to proper adjustment according to customers' usual practice.
7. It is advised to install control panels at places easy of maintenance, like a **weak electric well**.
8. It is strongly recommended that the exposed part of any connection terminal should **not be longer than 4mm**, and specialized clamping tools may be used to avoid short-circuit or communication failure resulting from accidental contact with excessive exposed wires.
9. To save access control event records, read data periodically from control panels.

10. Get prepared countermeasures according to application scenarios for unexpected power failure, like **selecting power supply with UPS**.
11. The connection between a card reader and a control panel **should not be longer than 100m**.
12. The connection between a PC and a control panel should be shorter than 1200m for RS485 communications. A length **within 600m** is recommended to make communications more stable.
13. To protect the access control system against the self-induced electromotive force generated by an electronic lock at the instant of switching off/on, it is necessary to **connect a diode in parallel** (please use the FR107 delivered with the system) with the electronic lock to release the self-induced electromotive force during onsite connection for application of the access control system.
14. It is recommended that an electronic lock and a control panel should **use respective power supplies**.
15. It is recommended to use the power supply delivered with the system as the control panel power supply.
16. In a place with strong magnetic interference, galvanized steel pipes or shielded cables are recommended, and proper grounding is required.
17. The appliance shall be installed and wired in accordance with national electrical code and by qualified personnel only.
18. The access control panel can be used in system provided the Access Level 1 only for resistance to Attack (protection level Class I for passage entry into a controlled area only according to ULC S319), and the minimum system configuration includes the access control panel, one of the following recognition devices: Keypad or Card Reader, and the locking devices. What appropriate peripherals could be connected with the control panel to provide the access level 1 system, the installer and/or end user must refer to requirements description of standard ULC S319 Appendix table C & D for details.

19. The control panel's compliance to ULC-S319, Electronic Access Control Systems, would be invalidated through the use of any add-on, expansion, memory or other module which not specified or defined by manufactured or manufacturer's representative.
20. The keypad shall be with minimum 10000 different codes, and with minimum ratio between the number of possibilities of codes and number of users of 20 to 1.

2 Introduction

The access control management system is a new modernized security management system, which is an effective measure for security and protection management. It is mainly used to manage entrances and exits of important places, such as banks, hotels, equipment rooms, offices, smart communities, and factories.

2.1 System Function Parameters

- High-speed 32-bit 400MHz CPU, 32M RAM, and 256M Flash.
- Embedded LINUX operating system.
- One-door/two-door two-way access or four-door one-way access.
- A maximum of 30,000 card holders and 100,000 offline event records.
- Support of multiple Wiegand card formats and a password keypad, compatible with various types of cards.
- Use of dual communication technologies: the Ethernet plus the RS485 industrial bus, for reliable communications.
- With a watchdog (hardware) built in the control panel to prevent crash.
- Over-current, over-voltage, and inverse-voltage protection for input of power supply to the control panel.

- Over-current protection for the power supply to card readers.
- Instant over-voltage protection for all input/output ports.
- Instant over-voltage protection for communication ports.

2.2 Product Technical Parameters

- Working power supply: Rated voltage 12V ($\pm 20\%$) DC; Rated current 2A.
- Working environment: Temperature 0°C-55°C; humidity 10%-80%.
- Electronic lock relay output: The maximum switching voltage: 36V(DC); The maximum switching current: 2A
- Lock ports rated max. 36VDC, 2A, and they are powered from external separated and listed power unit.
- Auxiliary relay output: The maximum switching voltage: 36V(DC); The maximum switching current: 1.25A
- With detachable connection terminals made of alloy-steel non-magnetic flange materials.
- Outline dimensions of the control PCB: 160mm (length) \times 106mm (width) for C3-100/200; 216mm (length) \times 106mm (width) for C3-400.
- External box dimensions: 360mm \times 285mm \times 75mm.

Valve regulated lead-acid battery:

- Constant voltage charge voltage regulation
- Cycle use : 14.5V~14.9V(25)
- Initial current: less than 2.88A
- Standby use: 13.6V~13.8V(25)
- Capacity: 12V, 7.2Ah/20hr,
- Battery Type: LC-RA127R2T1

Battery Caution:

- Do not charge in a gas tight container.
- Do not short the battery terminals.
- Do not incinerate
- Flush with water at once if contact is made with electrolyte (Acid)
- Do not attempt to disassemble the battery.

2.3 Control Operator Panel Indicators

When the C3-100/200/400 is powered on, normally the POWER indicator (red) is lit constantly, the RUN indicator (green) flashes (indicating the system is normal), and other indicators are all off.

Except the cases as follows:

1. LINK indicator (green): indicates proper TCP/IP connection if it is lit constantly;
2. ACT indicator (yellow): indicates transmission of TCP/IP data if it flashes;
3. TX indicator (yellow): indicates sending of 485 data if it flashes;
4. RX indicator (green): indicates receiving of 485 data if it flashes;
5. Lock indicator (green): indicates unlocking if it is lit constantly (if the auxiliary output indicator is lit in green constantly, it indicates the auxiliary device is enabled);
6. CARD indicator (yellow): indicates input of Wiegand signal if it is lit.

See the indicators in the following figure:

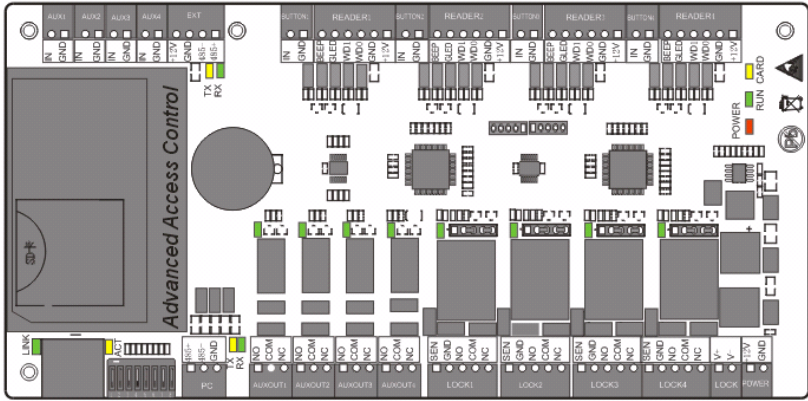
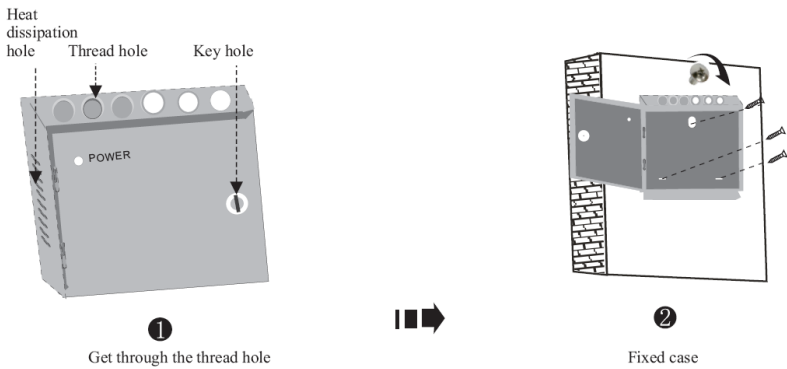

Figure 2-1 Indicators in the C3-400

3 Connection and Installation

3.1 Case Installation





Wiring the Control Panel, The Charging Circuit Board and Backup Battery

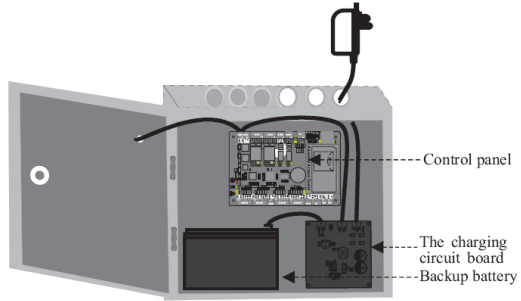

3.2 Installation of Access Control Operator Panel Wires

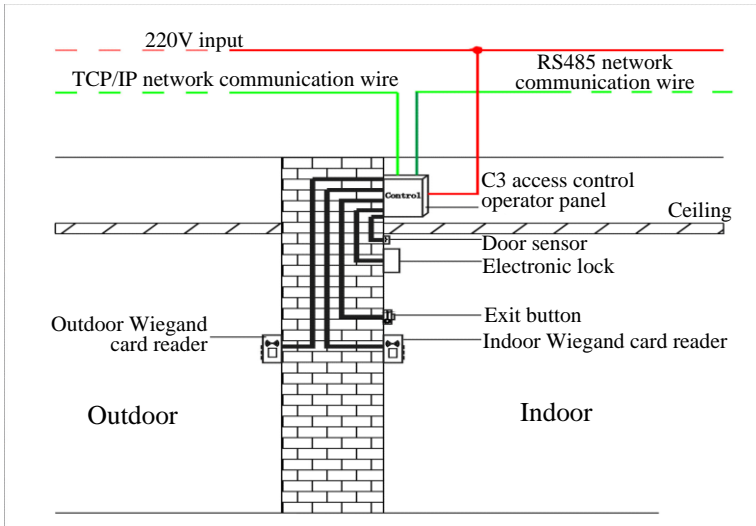

Figure 3-1 Access Control Operator Panel Wire Installation Diagram

Notes:

1. Before connection, make sure the power supply is disconnected, because connection with power connected will cause severe damage to the equipment.

- The access control wires must be separated according to heavy and light current; the control panel wires, electronic lock wires, and exit button wires must run through their respective casing pipes.

3.3 Control Operator Panel System Installation

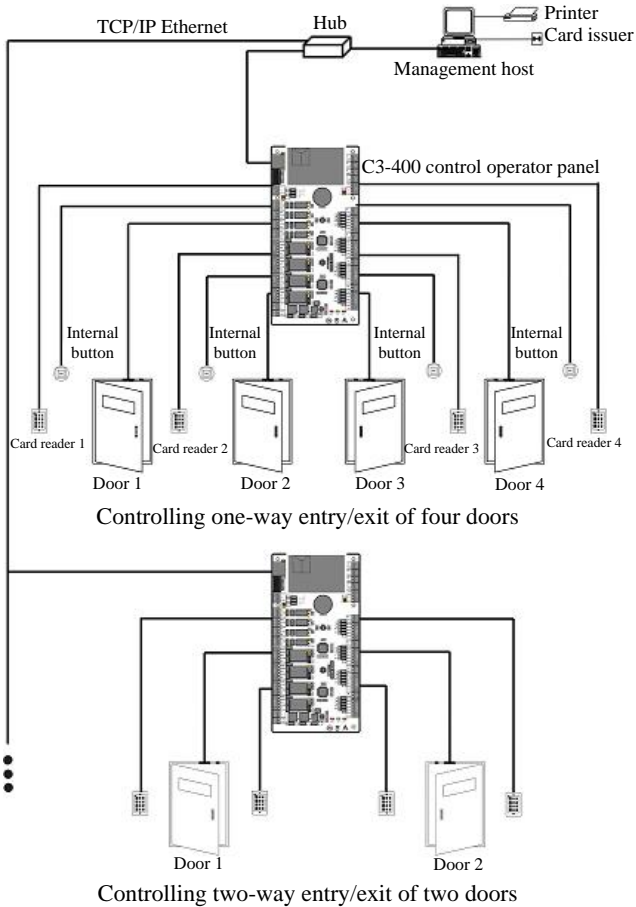



Figure 3-2 Schematic Diagram of C3-400 System Installation

 Note: The diagram above takes the C3-400 for example. By contrast, only one-door two-way access is applicable to the C3-100 system; only two-door one-way or two-door two-way access is applicable to the C3-200 system.

The access control management system consists of two parts: management workstation (PC) and control operator panel. They communicate via TCP/IP and RS485 networks. On a 485 bus, each management workstation can be connected with up to 63 C3 control operator panels (preferably fewer than 32). The communication wires should be kept away from high-voltage wires as far as possible, and should be neither routed in parallel with nor bundled with power wires.

A management workstation is actually a PC connected to the network. By running the access control management software installed in the PC, access control management personnel can remotely perform various management functions, like adding/deleting a user, viewing event records, opening/closing doors, and monitoring status of each door in real time.

3.4 Control Operator Panel Connection Terminals

C3-100 terminal connection diagram

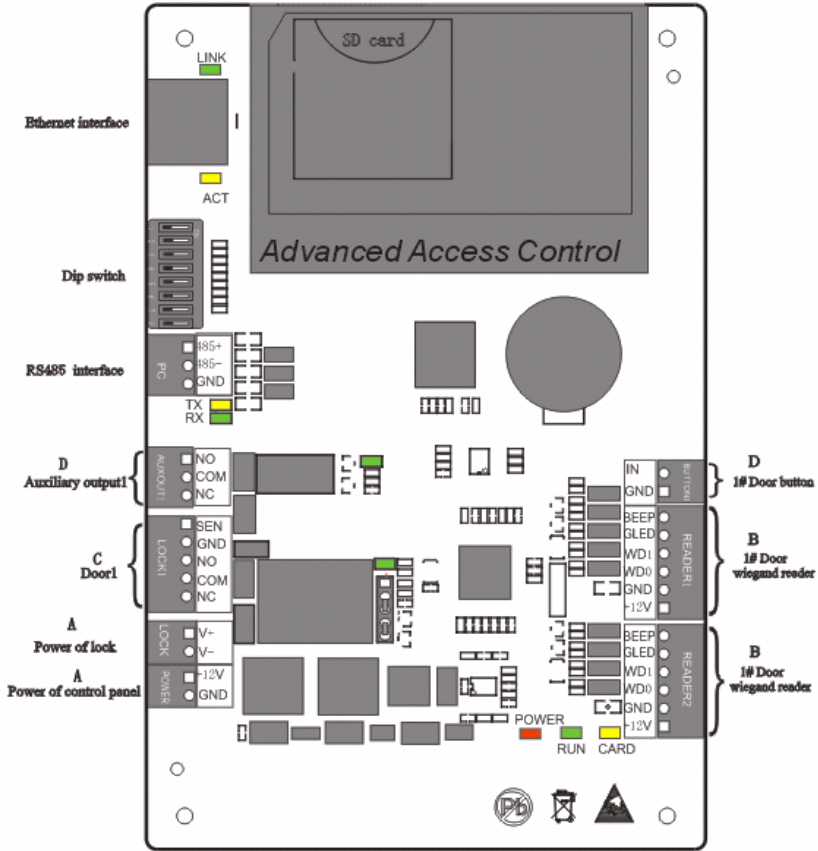

C3-200 terminal connection diagram

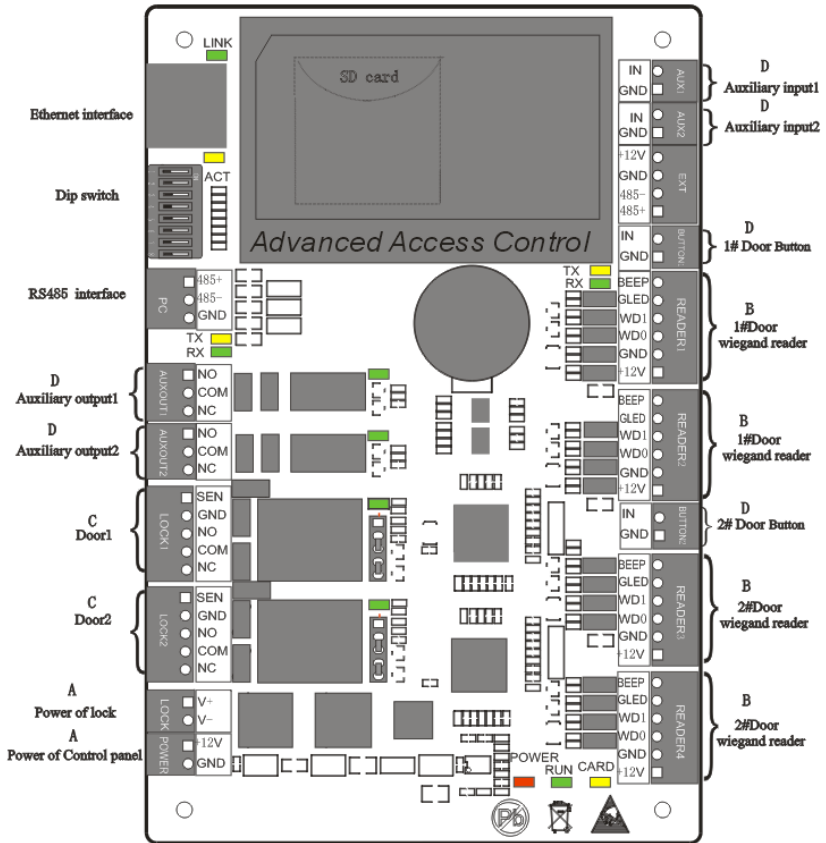

C3-400 terminal connection diagram

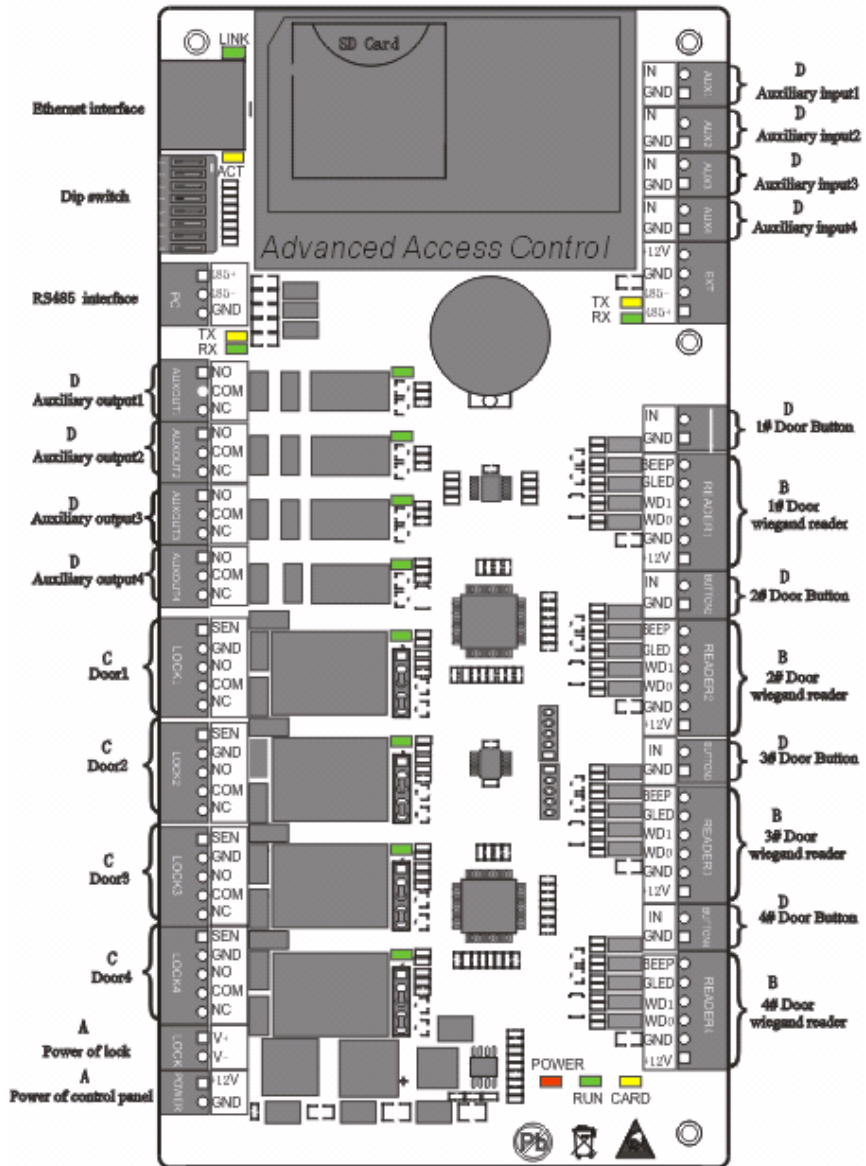

● Descriptions of the terminals:

1. **The auxiliary input may be connected to infrared body detectors, fire alarms, smoke detectors, etc.**
2. **The auxiliary output may be connected to alarms, cameras, door bells, etc.**
3. **All the terminals mentioned above are set through relevant access control software. Please see the respective software instructions for details.**

Ports on the C3 control operator panel:

No.	Functional Port	C3-100 (One-Door Two-Way)	C3-200 (Two-Door Two-Way)	C3-400 (Four-Door One-Way/Two-Door Two Way)
1	Wiegand card reader interface	2	4	4
2	Exit button	1	2	4
3	Control lock relay	1	2	4
4	Door sensor	1	2	4
5	Extension input	x	2	4
6	Extension output	1	2	4
7	RS485 & PC communication	√	√	√
8	RS485 extension communication	x	√	√
9	TCP/IP	√	√	√

3.5 Connection with Door Sensors, Exit Switches, and Auxiliary Input Devices

Door sensor

A door sensor is used to sense the open/closed status of a door. With a door sensor switch, an access control panel can detect illegal opening of a door, and will trigger an output of alarm. Moreover, if a door is not closed within a specified period of time after it is opened, the door control panel will also prompt an alarm. It is recommended to select two-core wires with a gauge over 0.22 mm². A door sensor may be omitted if it is unnecessary to monitor online the open/closed status of a door, give out an alarm when the door is not closed for a long time or there is illegal access, and use the interlock function.

Exit switch

An exit switch is a switch installed indoors to open a door. When it is switched on, the door will be opened. An exit button is fixed at a height of about 1.4m above the ground. Ensure it is located in the right position without slant, and its connection is correct and secure. (Cut off the exposed end of any unused wire and wrap it with insulating tape.) Note to guard against electromagnetic interference (such as light switches and computers). It is recommended to use two-core wires with a gauge over 0.3mm² as the connection wire between an exit switch and a control panel.

Auxiliary input

C3-100 provides no auxiliary input interface; C3-200 provides two, and C3-400 provides four, which are connected to infrared body detectors, smoke detectors, gas detectors, window magnetic alarms, wireless exit switches, etc. Auxiliary inputs are set through relevant access control software. For details, please see *ZKAccess4.0 User Manual*.

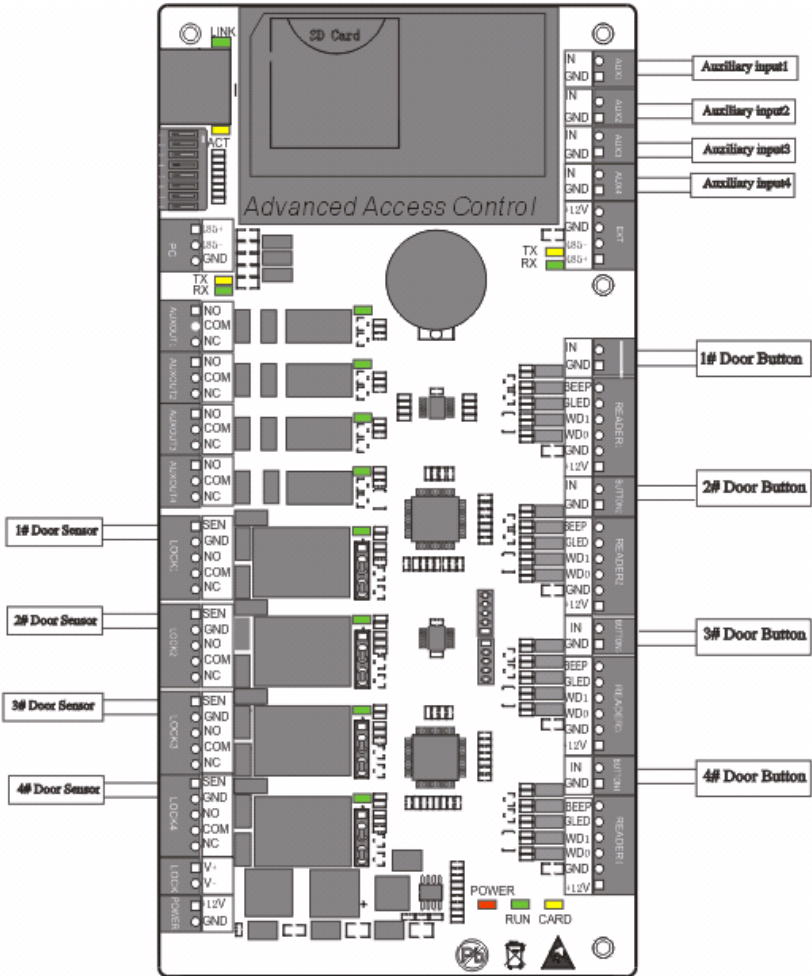



Figure 3-3 Connections between C3-400 and Door Sensors, Exit Switches, and Auxiliary Input Devices

 Note: The diagram above takes C3-400 for example. By contrast, C3-100 provides no auxiliary input interface; C3-200 provides two, and C3-400 provides four.

3.6 Connection with Wiegand Readers

C3-100 can connect two Wiegand readers in the one-door two-way mode. C3-200 provides four readers, which can be connected in the two-door two-way mode. C3-400 provides four readers, which can be connected in the two-door two-way or four-door one-way mode.

The Wiegand interfaces provided by the C3 series can be connected to different types of readers. If your card reader does not use the voltage of DC 12V, an external power supply is needed. A reader should be installed at a height of about 1.4m above the ground and at a distance of 30-50mm away from a door frame.

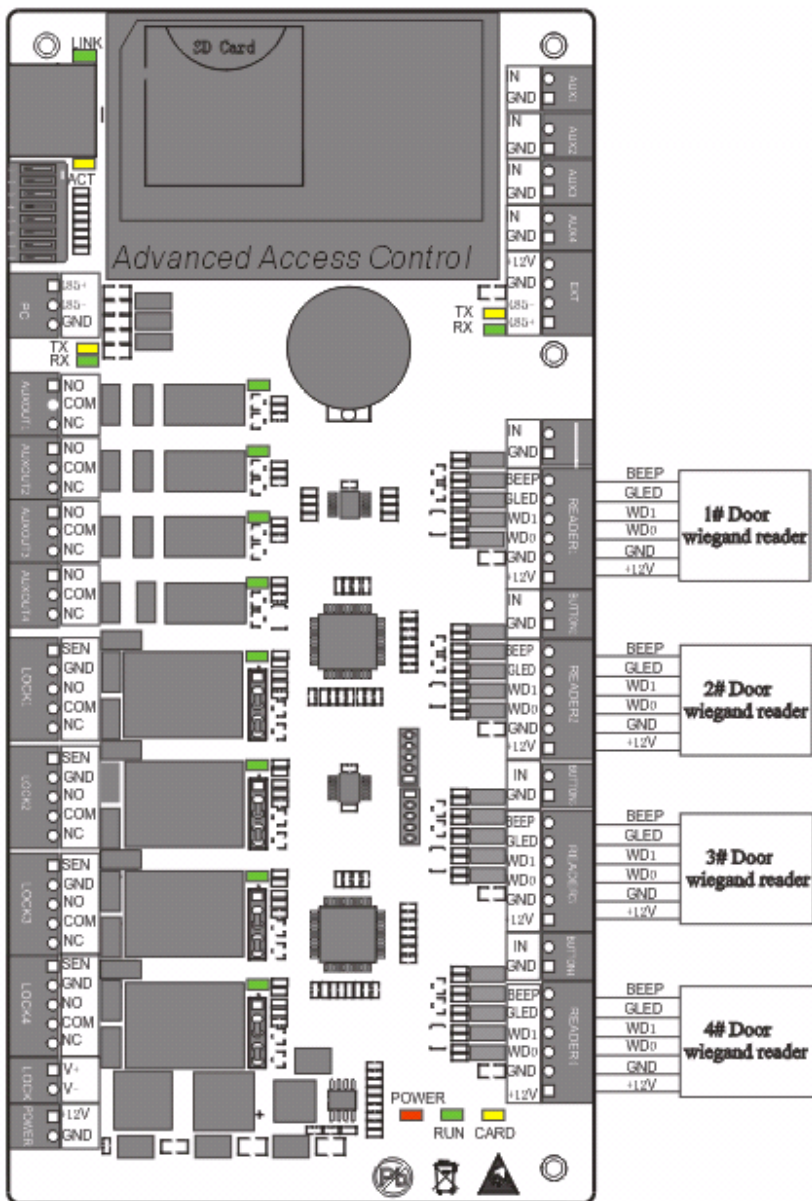

Figure 3-4 Connection between C3-400 and Readers

3.7 Relay Output Connection

C3-100 has two relays (one used as a control lock by default, and the other used as an auxiliary output); C3-200 has four relays (two used as control locks by default, and the other two used as auxiliary outputs); C3-400 has eight relays (four used as control locks by default, and the other four used as auxiliary outputs).

The relays for auxiliary outputs may be connected to monitors, alarms, door bells, etc. Auxiliary outputs are set through relevant access control software. For details, please see *ZKAccess4.0 User Manual*.

A lock relay can be connected in the dry and wet modes, while an auxiliary output relay cannot. The following illustrates relay output connection with an example of door connection.

1. An access control operator panel provides multiple electronic lock outputs. The COM and NO terminals are applicable to the locks that are unlocked when power is connected and locked when power is disconnected. The COM and NC terminals are applicable to the locks that are locked when power is connected and unlocked when power is disconnected.
2. By setting the jumper terminal beside the lock relay, you can select the device power supply or lock power supply for the lock (that is, the wet mode or dry mode).

Dry mode jumper setting: short 1-2 and 3-4, , and the device power supply will be used for the relay output.



Wet mode jumper setting: short 2-3 and 4-5, and the lock power supply will be used for the relay output.



 **Note:** The factory default jumping is set as dry mode.

3. To protect the access control system against the self-induced electromotive force generated by an electronic lock at the instant of switching off/on, it is

necessary to **connect a diode in parallel** (please use the FR107 delivered with the system) with the electronic lock to release the self-induced electromotive force during onsite connection for application of the access control system.

Below to C3-100 as an example to illustrate:

1. “Dry mode” wiring diagram of lock connecting with external power supply(recommend)

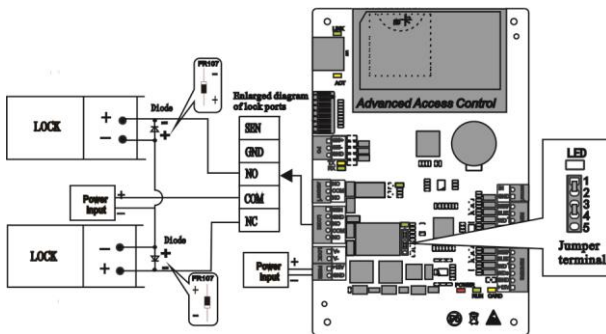

2. “Wet mode” wiring diagram of lock and controller common power supply

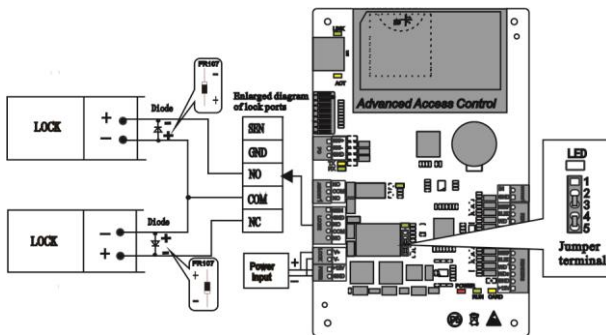

3.8 Access Control Operator Panel System Power Supply Structure

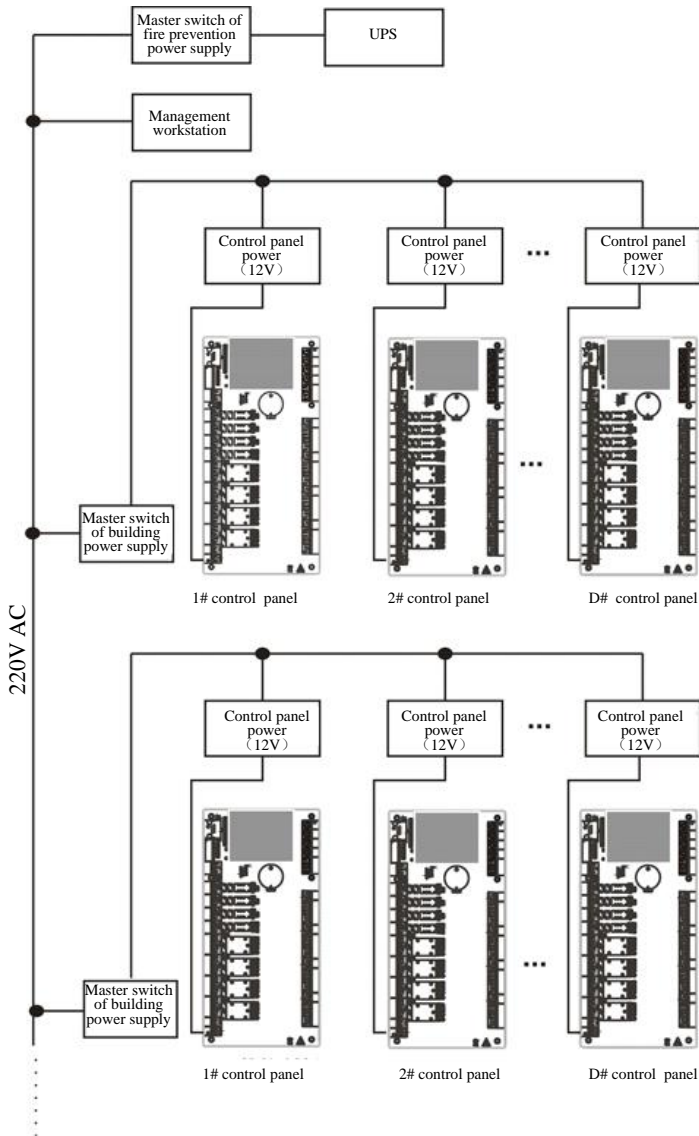

An access control operator panel is powered by +12V DC. Generally, to reduce power interference between control panels, each control operator panel should be powered separately. When high reliability is required, control panels and electronic locks should be powered respectively.

To prevent power failure of a control operator panel from making the whole system unable to work normally, the access control management system is usually required to have one UPS at least, and access control locks are powered externally to guarantee the access control management system can still work normally during power failure.

4 Access Control Operator Panel System Networking

4.1 Access Control Networking Wires and Wiring

1. RS485 communication wires are made of internationally accepted shielded twisted pairs, which prove effective to prevent and shield interference.
2. The power supply is 12V DC converted from 220V.
3. The Wiegand readers use 6-core communication shielded wires (RVVP 6×0.5mm) (usually there are 6-core, 8-core, and 10-core types available for users to select according to the ports) to reduce interference during transmission.
4. As an electronic lock has a big current, it generates strong interference signal during an action. To reduce the effect of an electronic lock during an action on other elements, 4-core wires (RVV 4×0.75mm², two for a power supply and two for a door sensor) are recommended.
5. Other control cables (like exit switches) are all made of 2-core wires (RVV 2×0.5mm²).
6. Notes for wiring:

- Signal wires (like network cables and RS-485 wires) can neither run in parallel with nor share one casing pipe with large-power electric wires (like electronic lock wires and power cables). If parallel wiring is unavoidable for environmental reasons, the distance must be over 50cm.
- Try to avoid use of any conductor with a connector during distribution. When a connector is indispensable, it must be crimped or welded. No mechanical force can be applied to the joint or branch of conductors.
- In a building, distribution lines must be installed horizontally or vertically. They should be protected in casing pipes (like plastic or iron water pipes, to be selected according to the technical requirements of indoor distribution). Metal hoses are applicable to ceiling wiring, but must be secure and good-looking.
- Shielding measures and shielding connection: If the electromagnetic interference in the wiring environment is found strong in the survey before construction, it is necessary to consider shielding protection for data cables when designing a construction scheme. Overall shielding protection is required if there is a large radioactive interference source or wiring has to be parallel with a large-current power supply on the construction site. Generally, shielding measures include: keeping a maximum distance from any interference source, and using metal wiring troughs or galvanized metal water pipes to ensure reliable grounding of the connection between the shielding layers of data cables and the metal troughs or pipes. Note that a shielding enclosure can have a shielding effect only when it is grounded reliably.
 - Ground wire connection method: Reliable large-diameter ground wires in compliance with applicable national standards are needed on the wiring site, and should be connected in a tree form to avoid DC loop. These ground wires must be kept far away from lightning fields. No lightning conductor can serve as a ground wire, and ensure there is no lightning current through any ground wire when

there is lightning. Metal wiring troughs and pipes must be connected continuously and reliably, and linked to ground wires through large-diameter wires. The impedance of this section of wire cannot exceed 2ohm. The shielding layer also must be connected reliably, and grounded at one end to guarantee uniform current direction. The ground wire of the shielding layer must be connected through a large-diameter (not smaller than 2.5mm²) wire.

4.2 TCP/IP Network Communication

The Ethernet 10/100Base-T Crossover Cable, a type of crossover network cable, is mainly used for cascade hubs and switches, or used to connect two Ethernet end-points directly (without a hub). Both 10Base-T and 100Base-T are supported.

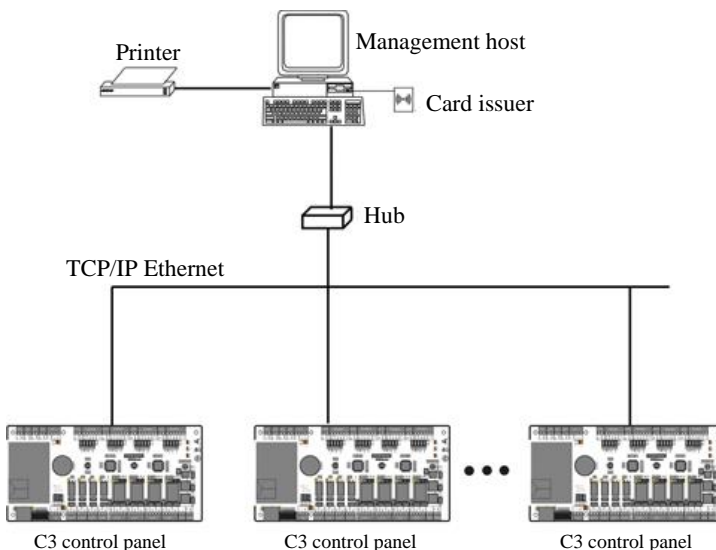

Figure 4-1 TCP/IP Communication System Networking

4.3 RS485 Network Communication

1. RS485 communication wires are made of internationally accepted RVSP wires (shielded twisted pairs), which prove effective to prevent and shield interference. RS485 communication wires should be connected by means of bus cascade instead of in a star form, to achieve a better shielding effect by reducing signal reflection during communications.
2. A single 485 bus can be connected with 63 access control operator panels at most, but preferably should be connected with less than 32.
3. To eliminate signal attenuation in communication cables and suppress interference, if the bus is longer than 300 meters, one 120ohm resistance is usually inserted between the first and last access control operator panels on the RS485 bus.
4. For this access control operator panel, putting place 8 of the DIP switch to the **ON** position is equivalent to parallel connection of one 120ohm resistance between the 485+ and 485- lines.

As shown in the figure below, put place 8 of the DIP switches of the first and last



control operator panels to the **ON** position.

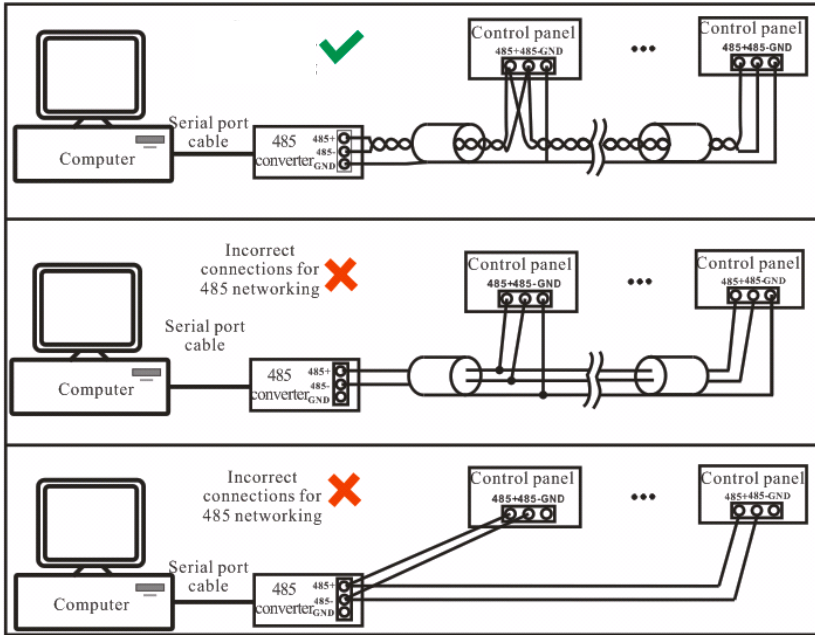

Figure 4-2 RS485 Communication System Networking

4.4 DIP Switch Setting (485 Address Setting, Factory Setting, and Terminal Resistance Setting)

● 485 address setting

Places 1-6 of the DIP switch are reserved to set device number for RS485 communication. The code is binary, and the lower places are in the front. When the switch is set to the **ON** position, it indicates 1 (on); when the switch is set downwards, it indicates 0 (off).

For example, to set a device number $39=1+2+4+32$, which corresponds to the binary code 111001, put places 1, 2, 3, and 6 to the **ON** position, as illustrated below.

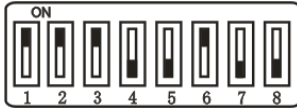

485 address setting table:

Place Address	Switch Setting					
	1	2	3	4	5	6
Address No.	1	2	4	8	16	32
01	ON	OFF	OFF	OFF	OFF	OFF
02	OFF	ON	OFF	OFF	OFF	OFF
03	ON	ON	OFF	OFF	OFF	OFF
04	OFF	OFF	ON	OFF	OFF	OFF
05	ON	OFF	ON	OFF	OFF	OFF
06	OFF	ON	ON	OFF	OFF	OFF
07	ON	ON	ON	OFF	OFF	OFF
08	OFF	OFF	OFF	ON	OFF	OFF
09	ON	OFF	OFF	ON	OFF	OFF
10	OFF	ON	OFF	ON	OFF	OFF
11	ON	ON	OFF	ON	OFF	OFF
12	OFF	OFF	ON	ON	OFF	OFF
13	ON	OFF	ON	ON	OFF	OFF
14	OFF	ON	ON	ON	OFF	OFF
15	ON	ON	ON	ON	OFF	OFF
16	OFF	OFF	OFF	OFF	ON	OFF
17	ON	OFF	OFF	OFF	ON	OFF
18	OFF	ON	OFF	OFF	ON	OFF
19	ON	ON	OFF	OFF	ON	OFF
20	OFF	OFF	ON	OFF	ON	OFF
21	ON	OFF	ON	OFF	ON	OFF
22	OFF	ON	ON	OFF	ON	OFF
23	ON	ON	ON	OFF	ON	OFF

Place Address	Switch Setting					
	1	2	3	4	5	6
24	OFF	OFF	OFF	ON	ON	OFF
25	ON	OFF	OFF	ON	ON	OFF
26	OFF	ON	OFF	ON	ON	OFF
27	ON	ON	OFF	ON	ON	OFF
28	OFF	OFF	ON	ON	ON	OFF
29	ON	OFF	ON	ON	ON	OFF
30	OFF	ON	ON	ON	ON	OFF
31	ON	ON	ON	ON	ON	OFF
32	OFF	OFF	OFF	OFF	OFF	ON
33	ON	OFF	OFF	OFF	OFF	ON
34	OFF	ON	OFF	OFF	OFF	ON
35	ON	ON	OFF	OFF	OFF	ON
36	OFF	OFF	ON	OFF	OFF	ON
37	ON	OFF	ON	OFF	OFF	ON
38	OFF	ON	ON	OFF	OFF	ON
39	ON	ON	ON	OFF	OFF	ON
40	OFF	OFF	OFF	ON	OFF	ON
41	ON	OFF	OFF	ON	OFF	ON
42	OFF	ON	OFF	ON	OFF	ON
43	ON	ON	OFF	ON	OFF	ON
44	OFF	OFF	ON	ON	OFF	ON
45	ON	OFF	ON	ON	OFF	ON
46	OFF	ON	ON	ON	OFF	ON
47	ON	ON	ON	ON	OFF	ON
48	OFF	OFF	OFF	OFF	ON	ON
49	ON	OFF	OFF	OFF	ON	ON
50	OFF	ON	OFF	OFF	ON	ON
51	ON	ON	OFF	OFF	ON	ON

Place Address	Switch Setting					
	1	2	3	4	5	6
52	OFF	OFF	ON	OFF	ON	ON
53	ON	OFF	ON	OFF	ON	ON
54	OFF	ON	ON	OFF	ON	ON
55	ON	ON	ON	OFF	ON	ON
56	OFF	OFF	OFF	ON	ON	ON
57	ON	OFF	OFF	ON	ON	ON
58	OFF	ON	OFF	ON	ON	ON
59	ON	ON	OFF	ON	ON	ON
60	OFF	OFF	ON	ON	ON	ON
61	ON	OFF	ON	ON	ON	ON
62	OFF	ON	ON	ON	ON	ON
63	ON	ON	ON	ON	ON	ON

● **Restoring factory setting**

The silk-screened **7** (place 7) of the DIP switch is the switch for restoration of system settings. The place is set to **OFF** by default. When place 7 is moved upwards and downwards for three times within 10 seconds and finally returned to the **OFF** position, the factory settings will be restored after the access control operator panel is restarted.

● **Terminal resistance setting**

Place 8 is for setting the RS485 termination resistance. Putting the switch to the **ON** position is equivalent to parallel connection of a 120ohm termination resistance between 485+ and 485-.

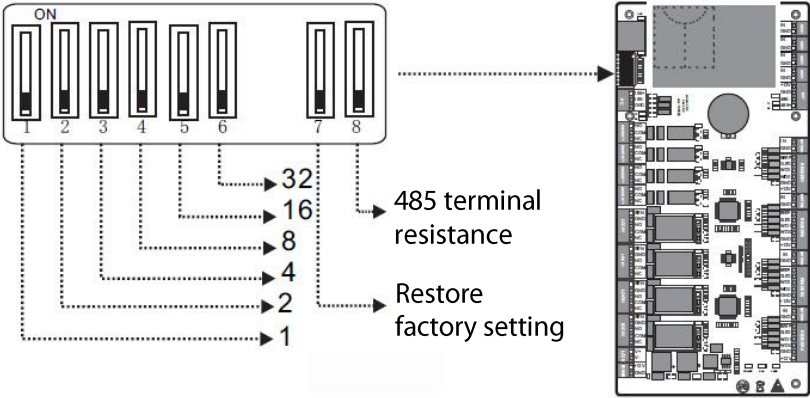

ZK Building, Wuhe Road, Gangtou, Bantian, Buji Town,
Longgang District, Shenzhen China 518129

Tel: +86 755-89602345

Fax: +86 755-89602394

www.zkteco.com

