

# Quick Start Guide

---

F35

Version: 1.1

# Overview

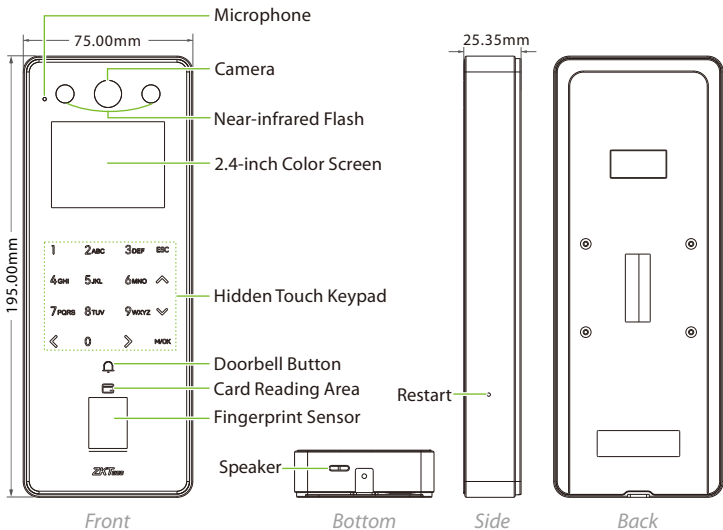

# Terminal Block

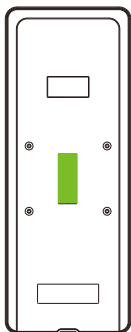

— BELL- —  
— BELL+ —  
— AL- —  
— AL+ —

*Bell & Alarm*

— GND —  
— AUX —  
— BUT —  
— SEN —  
— NC —  
— COM —  
— NO —

*Lock, Door Sensor, Exit Button & Auxiliary Input*

— INWD0 —  
— INWD1 —  
— GND —  
— 12VOUT —  
— RX232 —  
— 485A —  
— TX232 —  
— 485B —  
— WD1-OUT —  
— WDO-OUT —

*Wiegand, RS232 & RS485*



Power In



Network

# Installation Environment

Please refer to the following recommendations for installation.



KEEP DISTANCE



AVOID GLASS REFRACTION



AVOID DIRECT SUNLIGHT AND EXPOSURE



AVOID USE OF ANY HEAT SOURCE NEAR THE DEVICE

# Device Installation

- ① Stick the mounting template sticker to the wall and drill holes according to the mounting template sticker.
- ② Fix the backplate on the wall using wall mounting screws.
- ③ Attach the device to the backplate.
- ④ Attach the device to the backplate with a security screw.

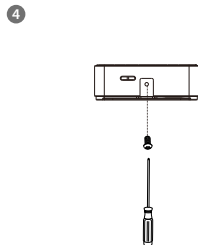
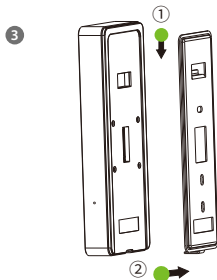
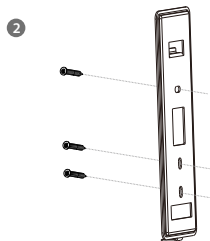
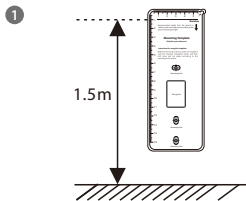

## Standalone Installation

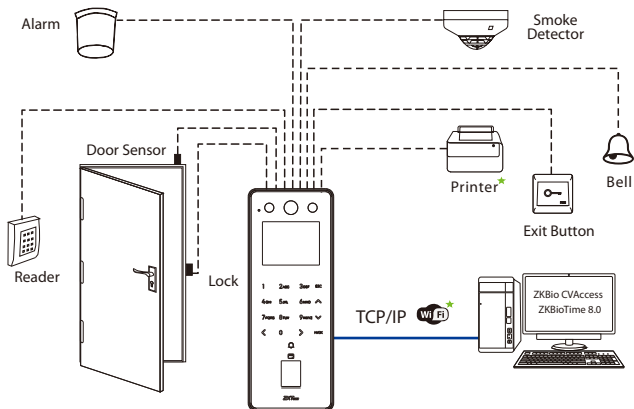

**Note:** Features and parameters with ★ mark are not available in all devices.

## Power Connection

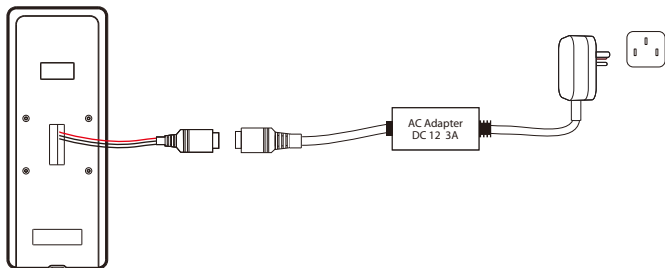

### Recommended AC Adapter

- 1)  $12V \pm 10\%$ , at least 3000mA.
- 2) To share the power with other devices, use an AC Adapter with higher current ratings.

## Ethernet Connection

Connect the device and computer software via an Ethernet cable. As shown in the example below:

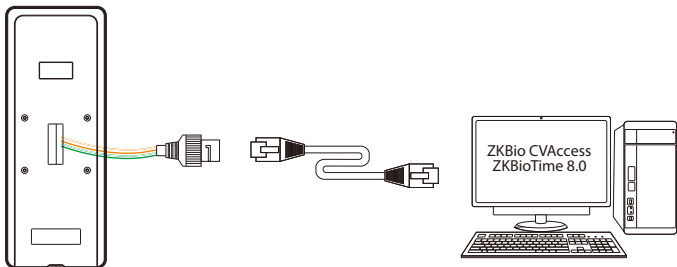

Default IP address: 192.168.1.201  
Subnet mask: 255.255.255.0

IP address: 192.168.1.130  
Subnet mask: 255.255.255.0

Click on [COMM.] > [Ethernet] > [IP Address], input the IP address and tap on [M/OK].

**Note:** In LAN, the IP address of the server (PC) and the device must be in the same network segment when connecting to the software.

## Wiegand Connection

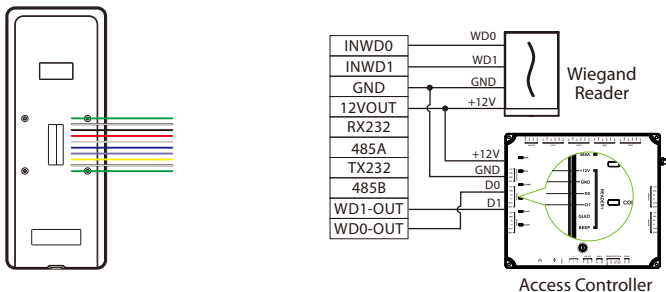

## RS485, RS232 & DM10\* Connection

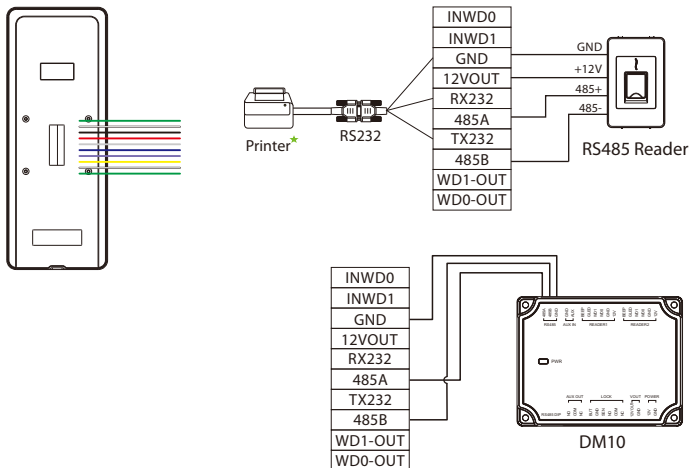

## Door Sensor, Exit Button, Alarm & Auxiliary Connection

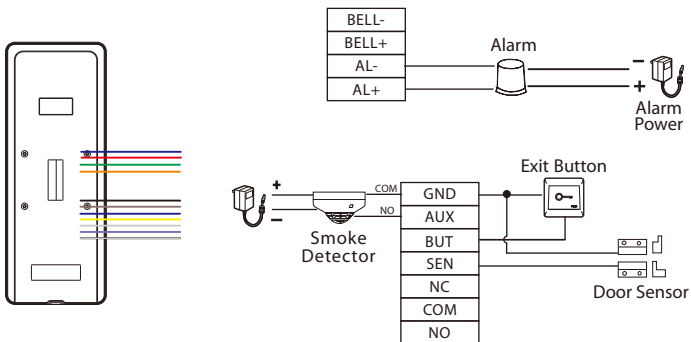

# Lock Relay Connection

The system supports **Normally Opened Lock** and **Normally Closed Lock**. The **NO LOCK** (normally unlocks when power-on) is connected with 'NO' and 'COM' terminals, and the **NC LOCK** (normally locks when power-on) is connected with 'NC' and 'COM' terminals. Take NC Lock as an example below:

## 1) Device not sharing power with the lock

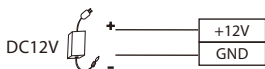

 Do not reverse the polarity.

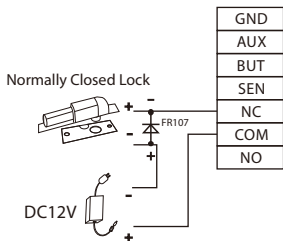

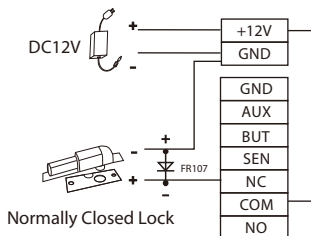

 Maximum 30V 3A input.

## 2) Device sharing power with the lock



## Connect the Wireless Doorbell★

This function needs to be used with the wireless doorbell.

First, power on the wireless doorbell. Then, press and hold the music button  for 1.5 seconds until you see the indicator start flashing. The flashing indicator shows that the doorbell is now in pairing mode. If the wireless doorbell rings and the indicator flashes, the connection has been successful, and you can then click on the device icon  to finish the process.

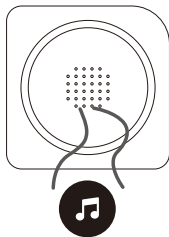

After a successful pairing, click the device icon  will ring the wireless doorbell.

### Note:

- 1) Each F35 only supports one wireless doorbell.
- 2) Wireless doorbell needs to be purchased by the customers themselves.



# User Registration

Press the **[M/OK]** key to access the main menu in case the device has not been configured with a super administrator. When creating a new user, assign the User Role as Super Admin. This action will prompt the system to request verification from the administrator before granting access to the menu. It is advisable to register a super administrator during the initial setup for enhanced security measures.

## Method 1: Registering on the Device:

Tap on **[M/OK]** > **[User Mgt.]** > **[New User]** to register a new user. There are several options available, including entering the user ID and name, setting the user role and access control role, and registering the fingerprint, card number and password.

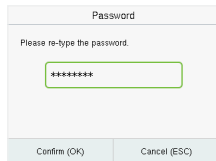
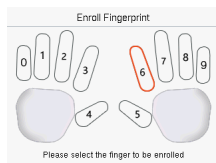
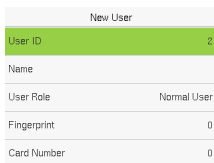
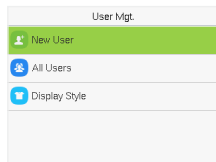
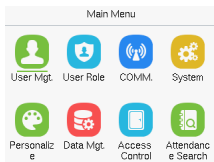
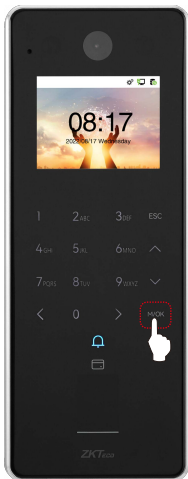

## Method 2: Register on ZKBio CVAccess software:

Please set the IP address and cloud service server address in the Comm. Menu option on the device.

1. Click **[Access]** > **[Device]** > **[Search]** > **[Search]** to search the device on the software. When an appropriate server address and port is set on the device, the searched device displays automatically.

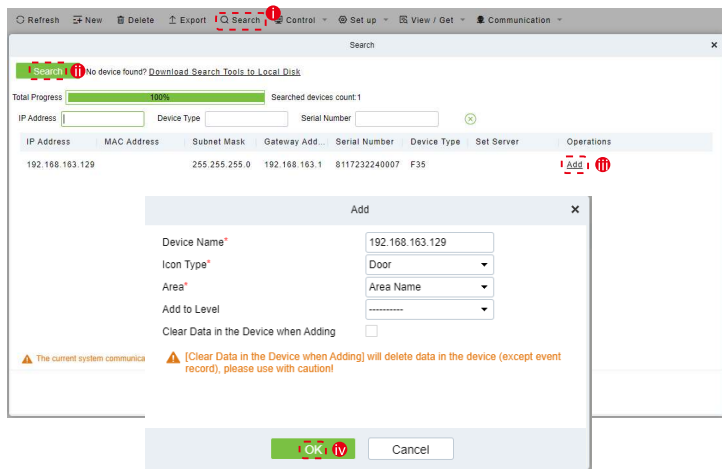

2. Click **[Add]** in operation column, a new window will pop-up. Select Icon type, Area, and Add to Level from each drop down list and click **[OK]** to add the device.
3. Click **[Personnel]** > **[Person]** > **[New]** and fill in all the required fields to register new users in the software.
4. Click **[Access]** > **[Device]** > **[Control]** > **[Synchronize All Data to Devices]** to synchronize all the data to the device including the new users.

For more details, please refer to the *ZKBio CVAccess User Manual*.

## Method 3: Register on the phone:

1. Click **[Personnel]** > **[Parameters]**, enter "http://Server address: Port" in the QR Code URL bar. The software will automatically generate a QR code. Scan the QR code or login onto "http://Server address: Port/tokenAdreg" by the mobile phone to register users.

The image shows two screenshots from the ZKBio CVAccess mobile application. The left screenshot displays the 'Personnel Registration' screen, which includes a profile picture of a man, a 'Personnel ID' field with the value '111', and 'First Name' and 'Last Name' fields both containing the value 'xia'. A green 'OK' button is at the bottom. The right screenshot shows the 'Parameters' screen under the 'Personnel' menu. It features a 'Pending personnel settings' section with 'Enable Auto-audit' set to 'No'. Below that is the 'Self-service Registration' section, where 'Enable Self Registration' is set to 'Yes' and the 'QR Code URL' is 'http://58.23.12.96:8080/tokenAdreg'. A QR code is displayed below the URL, with a red box around it and a 'Download QR code image' link. At the bottom, there is a 'Personal sensitive information protection' section with checkboxes for 'Personnel ID', 'Last Name', 'Certificate Number', 'Email', 'First Name', 'Gender', 'Mobile Phone', and 'Birthday', all of which are checked. A green 'OK' button is at the bottom of this section.

2. The users will be displayed in **[Personnel]** > **[Pending Review]**. Click the **[Review]** option and assign a department, then click **[OK]** to successfully add the user.

The image shows a screenshot of the ZKBio CVAccess mobile application in the 'Pending Review' section. A table lists personnel with columns for 'Personnel ID', 'First Name', 'Last Name', 'Mobile Phone', 'Status', 'Change Time', and 'Operations'. One entry is visible with ID '111', name 'xia', and status 'Pending review'. A 'Review' dialog box is open over the table, showing a profile picture of the same man and fields for 'Personnel ID' (111), 'First Name' (xia), 'Last Name' (xia), 'Mobile Phone', 'Card Number', 'Department' (with a dropdown menu), 'Area Name' (with a dropdown menu), and 'Access Levels'. The dialog has 'OK' and 'Cancel' buttons at the bottom.

# Ethernet and Cloud Server Settings

Tap on [M/OK] > [COMM.] > [Ethernet] to set the network parameters. If the TCP/IP communication of the device is successful, the icon  will be displayed in the upper right corner of the standby interface.

Tap on [M/OK] > [COMM.] > [Cloud Server Settings] to set the server address and server port. For example, set the IP address and port number of the server after the software is installed. If the device communicates with the server successfully, the icon  will be displayed in the upper right corner of the standby interface.

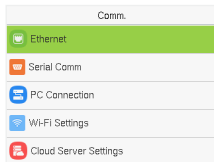
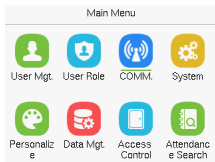

Ethernet	
IP Address	192.168.163.99
Subnet Mask	255.255.255.0
Gateway	192.168.163.1
DNS	0.0.0.0
TCP COMM.Port	4370

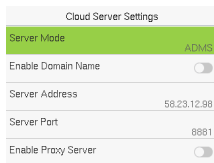
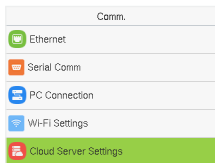

## Note:

During the process of pairing the device with the ZKBio CVAccess / ZKBioTime8.0 software.

**Server Address:** Set as the IP address of the ZKBio CVAccess / ZKBioTime8.0 server.

**Server Port:** Set as the Adms service port of ZKBio CVAccess / ZKBioTime8.0.

# Connect to ZSmart★

After downloading and installing the ZSmart App on your phone, open the application and proceed to add the device by scanning the QR code. The steps for this process are as follows:

1. On the device, tap on **[M/OK] > [System] > [Video Intercom Parameters] > [QR Code Binding]**.

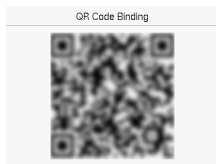
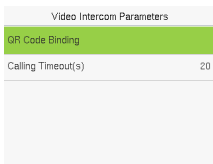
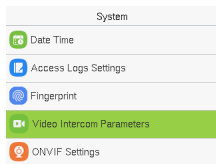

2. On the App, click **[Add Device]** at Home Page.
3. Click the  icon in the upper right corner to scan the QRcode and add the device.

**Note:** First, the device needs to connect to the network.

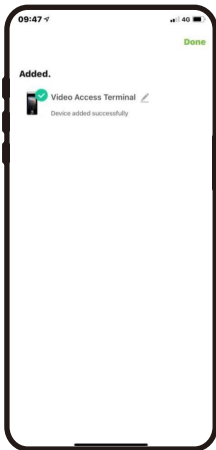
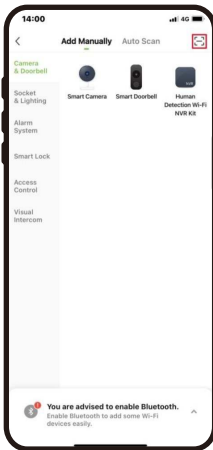
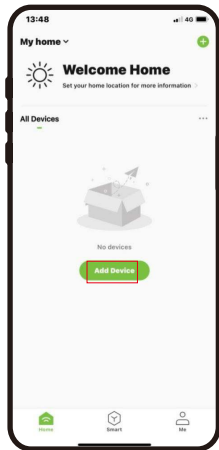

Visitors click the  on the device to call and then phone will ring. The user can select accept or decline the call. After accepting the call, it will enter the video door phone interface.

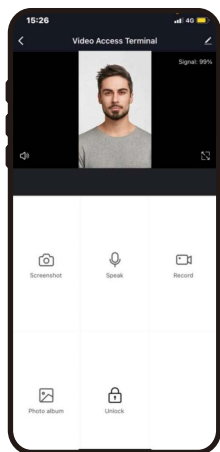
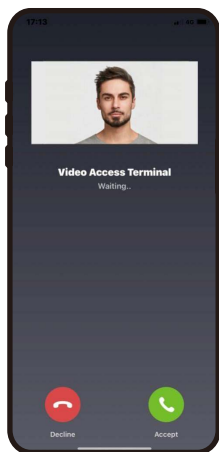
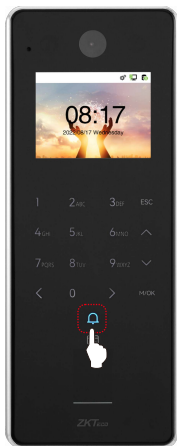



4. Select the checkbox for the device you want to add and edit the parameters in the corresponding text field, then click on **OK** to add it to the connection list.

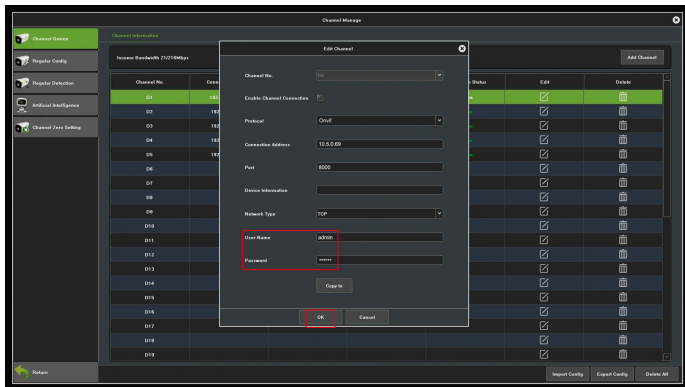

5. After successfully adding, the video image obtaining from the device can be viewed in real-time.

For more details, please refer to the *NVR User Manual*.



# SIP Settings★

This function needs to be used with the indoor station.

## Local Area Network Use

1. Set the indoor station to the same network segment as the device.
2. On the **SIP Settings** interface, click on **Account > Dtmf** to set the value as same as the value of DTMF in the indoor station.
3. Click on **Contact List > Add** to add the connected indoor station.  
**Device Number:** Customize the number of the indoor station.  
**Call Address:** it is the IP Address of the indoor station.

**Note:** You can also configure the parameters on the Webserver.

### ● Enter the IP Address/Device Number of the Indoor Station

Tap the  icon on the device and enter the IP address/Device Number of the indoor station in the pop-up interface of the device.

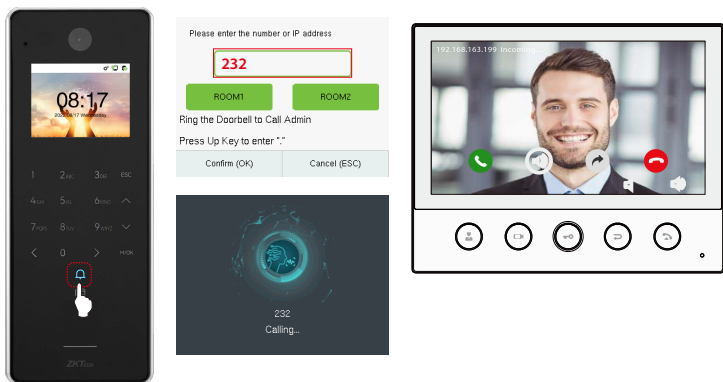

### ● Calling Shortcut Keys

1. On the **SIP Settings** interface, click on **Calling Shortcut Settings** to define the shortcut keys.  
**Name:** Customize the name of the shortcut keys.  
**Device Number:** It is the device number that set in the **Contact List** Menu.

2. Tap the  icon on the device and click the calling shortcut keys to call the indoor station.

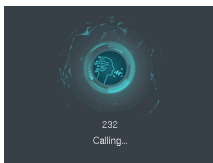
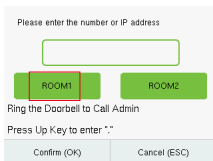

## ● Direct Calling

1. On the **SIP Settings** interface, click on **Calling Shortcut Settings** > **Call Mode** > **Direct Calling Mode** > **Add**. Select the IP addresses of the indoor stations that you want to call, then the indoor stations will be displayed in the list.
2. Tap the  icon on the device to call the indoor stations at the same time.

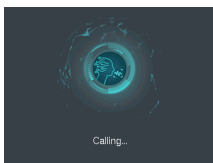
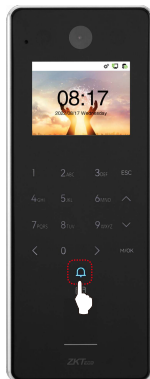

## SIP Server

1. On the **SIP Settings** interface, click on **Account > SIP Server** to enable it, enter the server-related parameters.
2. Once the SIP is set up correctly, a green dot will appear in the upper right corner of the call page to indicate that the F35 is connected to the server. You can call the account name of the indoor station.

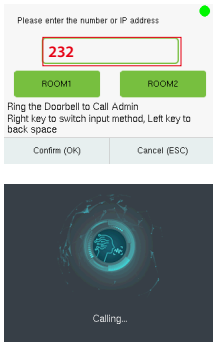

For more details, please refer to the *F35 User Manual*.

ZKTeco Industrial Park, No. 32, Industrial Road,  
Tangxia Town, Dongguan, China.

Phone : +86 769 - 82109991

Fax : +86 755 - 89602394

[www.zkteco.com](http://www.zkteco.com)

