

User Manual

AMT-FAM-10

Date: October 2022

Doc Version: 1.2

English

Thank you for choosing our product. Please read the instructions carefully before operation. Follow these instructions to ensure that the product is functioning properly. The images shown in this manual are for illustrative purposes only.



For further details, please visit our Company's website
www.armatura.us.

Copyright © 2022 ARMATURA LLC. All rights reserved.

Without the prior written consent of ARMATURA LLC no portion of this manual can be copied or forwarded in any way or form. All parts of this manual belong to ARMATURA and its subsidiaries (hereinafter the "Company" or "ARMATURA").

Trademark

ARMATURA is a registered trademark of ARMATURA LLC. Other trademarks mentioned in this manual are the properties of their respective owners.

Disclaimer

This manual contains information on the operation and maintenance of the ARMATURA product. The copyright in all the documents, drawings, etc. in relation to the ARMATURA supplied product vests in and is the property of ARMATURA. The contents hereof should not be used or shared by the receiver with any third party without express written permission of ARMATURA.

The contents of this manual must be read as a whole before starting the operation and maintenance of the supplied product. If any of the content(s) of the manual seems unclear or incomplete, please contact ARMATURA before starting the operation and maintenance of the said product.

It is an essential pre-requisite for the satisfactory operation and maintenance that the operating and maintenance personnel are fully familiar with the design and that the said personnel have received thorough training in operating and maintaining the machine/unit/product. It is further essential for the safe operation of the machine/unit/product that personnel have read, understood, and followed the safety instructions contained in the manual.

In case of any conflict between terms and conditions of this manual and the contract specifications, drawings, instruction sheets or any other contract-related documents, the contract conditions/documents shall prevail. The contract specific conditions/documents shall apply in priority.

ARMATURA offers no warranty, guarantee, or representation regarding the completeness of any information contained in this manual or any of the amendments made thereto. ARMATURA does not extend the warranty of any kind, including, without limitation, any warranty of design, merchantability, or fitness for a particular purpose.

ARMATURA does not assume responsibility for any errors or omissions in the information or documents which are referenced by or linked to this manual. The entire risk as to the results and performance obtained from using the information is assumed by the user.

ARMATURA in no event shall be liable to the user or any third party for any incidental, consequential, indirect, special, or exemplary damages, including, without limitation, loss of business, loss of profits, business interruption, loss of business information or any pecuniary loss, arising out of, in connection with, or relating to the use of the information contained in or referenced by this manual, even if ARMATURA has been advised of the possibility of such damages.

This manual and the information contained therein may include technical, other inaccuracies, or typographical errors. ARMATURA periodically changes the information herein which will be incorporated into new additions/amendments to the manual. ARMATURA reserves the right to add, delete, amend, or modify the information contained in the manual from time to time in the form of circulars, letters, notes, etc. for better operation and safety of the machine/unit/product. The said additions or amendments are meant for improvement /better operations of the machine/unit/product and such amendments shall not give any right to claim any compensation or damages under any circumstances.

ARMATURA shall in no way be responsible (i) in case the machine/unit/product malfunctions due to any non-compliance of the instructions contained in this manual (ii) in case of operation of the machine/unit/product beyond the rate limits (iii) in case of operation of the machine and product in conditions different from the prescribed conditions of the manual. The product will be updated from time to time without prior notice. The latest operation procedures and relevant documents are available on <http://www.armatura.us>.

If there is any issue related to the product, please contact us.

ARMATURA Headquarters

Address 190 Bluegrass Valley Pkwy,
 Alpharetta, GA 30005.

For business-related queries, please write to us at info@armatura.us.

To know more about our global branches, visit www.armatura.us.

About the Company

ARMATURA is a leading global developer and supplier of biometric solutions which incorporate the latest technologies on biometric hardware design, algorithm research and software development. ARMATURA holds numerous patents in the field of biometric recognition technologies. Its products are primarily used in business applications which require high-secured, high-accurate and fast matching and identification processes.

ARMATURA biometric hardware and software are built into the product of world top workforce management (WFM) solution providers, Point-of-Sale (PoS) terminals vendors, intercoms, electronic safes, metal key lockers, dangerous machinery, and many other product vendors which heavily rely on accurate, secured and fast user identification features.

About the Manual

This manual introduces the operations of AMT-FAM-10, a dual-lens near-infrared light and visible light face module.

All figures displayed in this manual are for illustration purposes only which may not be exactly consistent with the actual product.

Document Conventions

Conventions used in this manual are listed below:

GUI Conventions

For Software	
Convention	Description
Bold font	Used to identify software interface names e.g. OK, Confirm, Cancel.
>	Multi-level menus are separated by these brackets. For example, File > Create > Folder.
For Device	
Convention	Description
< >	Button or key names for devices. For example, press <OK>.
[]	Window names, menu items, data table, and field names are inside square brackets. For example, pop up the [New User] window.
/	Multi-level menus are separated by forwarding slashes. For example, [File/Create/Folder].

Symbols





Convention	Description
	This represents a note that needs to pay more attention to.
	The general information which helps in performing the operations faster.
	The information which is significant.
	Care taken to avoid danger or mistakes.
	The statement or event that warns of something or that serves as a cautionary example.

Table of Contents

1	PRODUCT INTRODUCTION	7
	1.1 OVERVIEW	7
	1.2 FEATURES.....	7
2	PRODUCT SPECIFICATIONS	8
	2.1 TECHNICAL SPECIFICATIONS.....	8
	2.2 ELECTRICAL FEATURES.....	8
	2.3 OPTICAL AND IMAGE SPECIFICATIONS	9
	2.4 MODEL SPECIFICATIONS.....	10
3	ALGORITHM SPECIFICATIONS.....	10
4	APPLICATION SCENARIOS	11
5	STRUCTURAL DIMENSIONS.....	12
6	PIN SOCKET DEFINITION	13
	6.1 PIN SOCKET POSITION AND DEFINITION	13
	6.2 PIN SOCKET DIMENSIONS.....	14
7	USB CABLE REQUIREMENTS	14
	7.1 USB TYPE-A CABLE.....	14
	7.2 PLUG WIRE	15
8	DESIGN GUIDE.....	15
	8.1 FRONT LENS DESIGN.....	15
	8.2 HEAT DISSIPATION DESIGN	17
9	INSTALLATION GUIDE	18
	9.1 INSTALLATION METHOD.....	18
	9.2 VERTICAL MOUNT APPROACH.....	20
	9.3 TILTING MOUNT APPROACH.....	20
	9.4 RECOMMENDED INSTALLATION HEIGHT AND MOUNTING ANGLE	21
10	FACIAL EXPRESSIONS AND STANDING POSTURE	21

1 Product Introduction

1.1 Overview

AMT-FAM-10 is a high-performance dual-lens face image capturing module that supports both visible light and near-infrared light images. This module is equipped with an optical camera with a wide dynamic imaging sensor, a megapixel lens, and near-infrared-light LEDs.

The model is also equipped with a high-performance processor with a frequency of 400MHz, capable of capturing high-quality visible and near-infrared face images. It supports USB interface communication and external power supply in one single cable.

AMT-FAM-10 utilizes the Infrared light imaging sensor to capture grayscale face images for face recognition process by integrating with AMT FaceLite SDK, and the visible light camera captures the true color face image for display and other relevant process. Combined with AMT FaceLite SDK, the captured face grayscale image and true color image are utilized for liveness detection and anti-spoofing protection process. AMT FaceLite SDK well fits to integrate facial recognition features into business applications.

For price-sensitive customers, the module and AMT FaceLite SDK together provide a cost-effective biometric authentication solution. The solution can be applied to a wide range of applications such as time attendance, access control, entrance management, payment kiosks, intercoms, turnstiles which are running on windows PCs, Android tablets, Linux based devices and other hardware platforms.

1.2 Features

- Supports Visible Light and Near-Infrared face image acquisition.
- Built-in wide dynamic imaging sensor suitable for the various lighting conditions.
- Works with AMT FaceLite SDK to perform liveness detection and anti-spoofing process with grayscale face images and true color face images.
- Supports integration with third-party applications on Windows, Android or Linux operating systems via AMT FaceLite SDK.

- Compatible with USB 2.0 specifications.
- Low power consumption with operating power less than 2W.
- Supports wide field of view which is adaptable to varieties of individual's height.
- Compact, light-weight size with USB 2.0 interface which simplifies integration with various hardware devices.
- Provides hygienic and non-invasive touchless identification solution which makes it stress free for public use.

2 Product Specifications

2.1 Technical Specifications

Features	Technical Specifications
Processor	Low-power-consumption processor, 400MHz
Image Sensor	Dual 1/2.7", HDR CMOS (support visible and Near-infrared light)
Connector	7-pin 1.25mm USB 2.0
Communication Interface	USB 2.0 (High speed)
Power Supply	USB 5V
Power Consumption	1.0W (Standby) / 1.75W (Operating)
Dimensions	60 * 22 * 19.30 mm (± 1 mm)
Certifications	CE, FCC, RoHS

2.2 Electrical Features

Specifications	Test Conditions	Min	Standard	Max
Operating Voltage	-	4.75V	5.0V	5.25V

Specifications	Test Conditions	Min	Standard	Max
Operating Current	T = 25°C/77°F, VCC = 5.0 V	-	350mA	400mA
Operating Power Consumption	T = 25°C/77°F, VCC = 5.0 V	-	1.75W	2.0W
Standby Current	T = 25°C/77°F, VCC = 5.0 V	-	200mA	220mA
Standby Power Consumption	T = 25°C/77°F, VCC = 5.0 V	-	1.0W	1.1W
Operating Temperature	-	-10°C/14°F	-	55°C/131°F
Storage Temperature	-	-20°C/-4°F	-	80°C/176°F

2.3 Optical and Image Specifications

Features	Technical Specifications	
Sensor Model	HDR CMOS Sensor	
Sensor Size	1/2.7 inch	
Sensor Type	Optical	
Image Size	720W x 1280H (Pixel)	
Dynamic Range	83 dB	
Max. Frame Rate	12 fps	
Lens Type	RGB	IR
Optical Wavelength	440 to 650 nm	840 to 860 nm
Field of View (FOV)	Diagonal = 74°, Horizontal = 40°, Vertical = 65°	
Optical Distortion Rate	≤1%	
Lens Composition	Composed of 4-Plastic Lens and an IR-Filter (4P+1IR)	
Default Output Format	MJPEG	

Recognition Distance	40 cm to 80 cm
----------------------	----------------

2.4 Model Specifications

Features	Technical Specifications
SDK	AMT FaceLite SDK 12
Recognition Angle	Yaw \leq 25°, Pitch \leq 25°, Roll \leq 25°
Recognition Method	1:1 and 1:N
Capacity	6,000 templates
Accuracy	TAR=98.6% when FAR=0.001%
Recognition Time*	<300ms
Windows	Windows XP / Windows 7 / Windows10 (32/64bits)
Android	Android 4.1 or higher version

Notes:

* The performance is based on Quad-core Cortex-A9 up to 1.6GHz platform.

3 Algorithm Specifications

AMT FaceLite 12.0 is an excellent near-infrared face recognition algorithm based on the indoor face recognition algorithm which is adaptable to various lighting conditions and meets the requirement on large volume recognition case. To ensure a very low False Rejection Rate (FRR), the algorithm focuses on improving the adaptability to the deployed environment and user experience, thereby achieves the robustness and high-pass rate of face recognition.

The SDK libraries assist to enhance the security requirements through facial recognition which protects spoofing attack and is widely used in various business applications, including attendance,

security, video surveillance and more. Face recognition specifications are presented in the following table.

Algorithm Version	AMT FaceLite 12.0
Face Detection Speed	< 50 ms
Biometric Template Extraction Speed	< 200 ms
Biometric Comparison Speed	< 100 ms
Face Capacity	6,000
Posture Adaptability	Yaw $\leq 25^\circ$, Pitch $\leq 25^\circ$, Roll $\leq 25^\circ$
Precision	TAR=98.6% when FAR=0.001%

Note:

The algorithm performance is tested based on a proprietary image data set with image size of 480W x 640H pixel and on quad-core Cortex-A9 @1.5 GHz processor platform.

4 Application Scenarios

The AMT-FAM-10 module is optimized on its physical structure for the purpose of the built-in design and integration, facilitating easy and fast integration into third-party hardware device. Kept the integration thought into design, the module can be built into a host device using a single USB cable which provides both the power supply and data communication, this approach simplifies the integration development work considerably.

With AMT FaceLite SDK, you only need to write a few lines of code to call the SDK interfaces to achieve face recognition in your application. It speeds the development work and improves the productivity. The integration solution can be applied to various business applications such as time attendance, access control, entrance management, payment kiosks, intercom units, turnstiles, PCs, tablets, and more.

5 Structural Dimensions

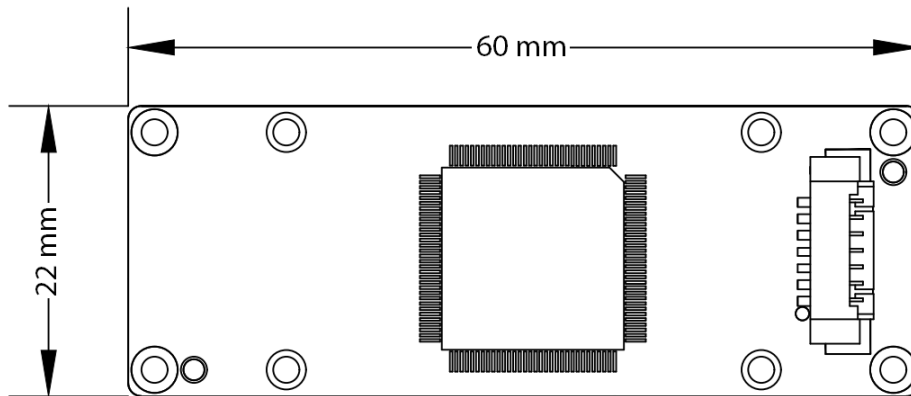

Figure 5.1 Bottom view

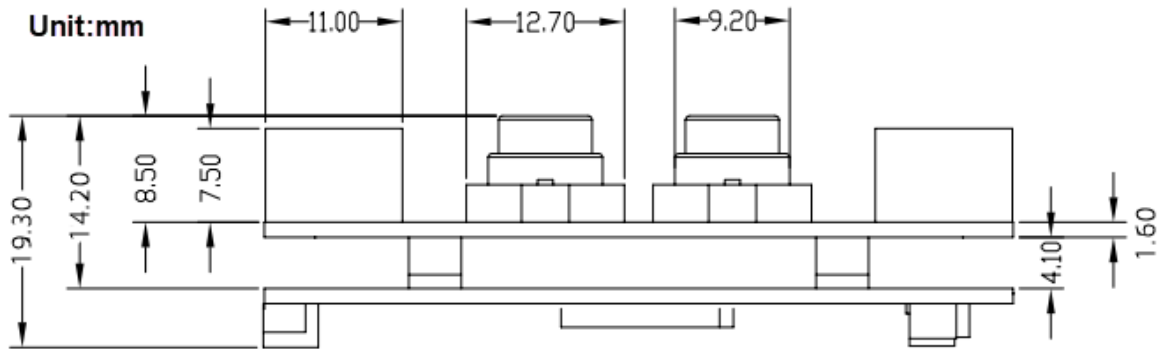

Figure 5.2 Side view

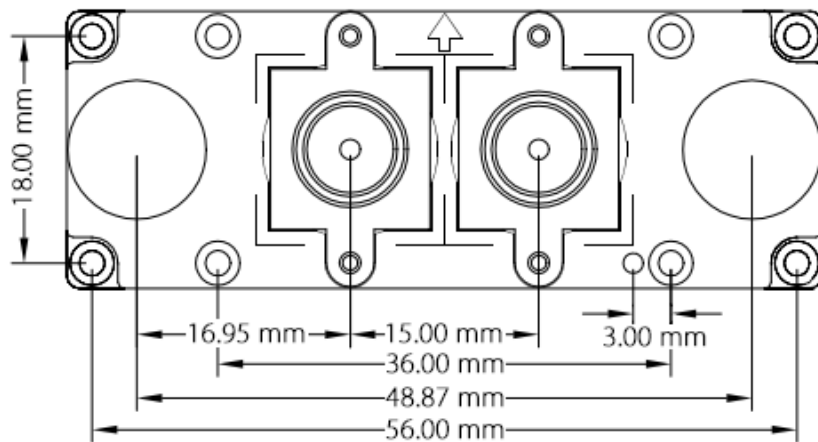

Figure 5.3 Top view

6 PIN Socket Definition

6.1 PIN Socket Position and Definition

The pin socket includes the USB communication and power supply pins, and the position and pin definition of the interface is shown in Figure 6.1 below.

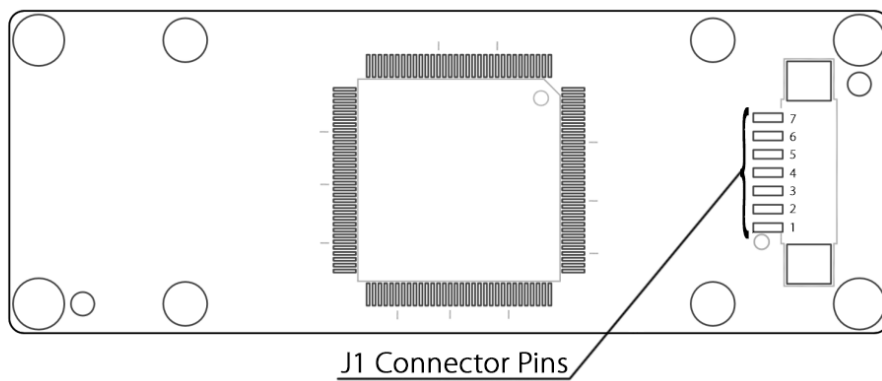

Figure 6.1 J1 Connector (7 Pin)

Pin Description

J1 (7 Pin / 1.25 mm)							
PIN	1	2	3	4	5	6	7
Detail	+5V	GND	Shield GND	USB-	USB+	Reserved	Reserved

6.2 PIN Socket Dimensions

The structural dimensions of the 7 Pin connector of the module are shown in Figure 6.2.

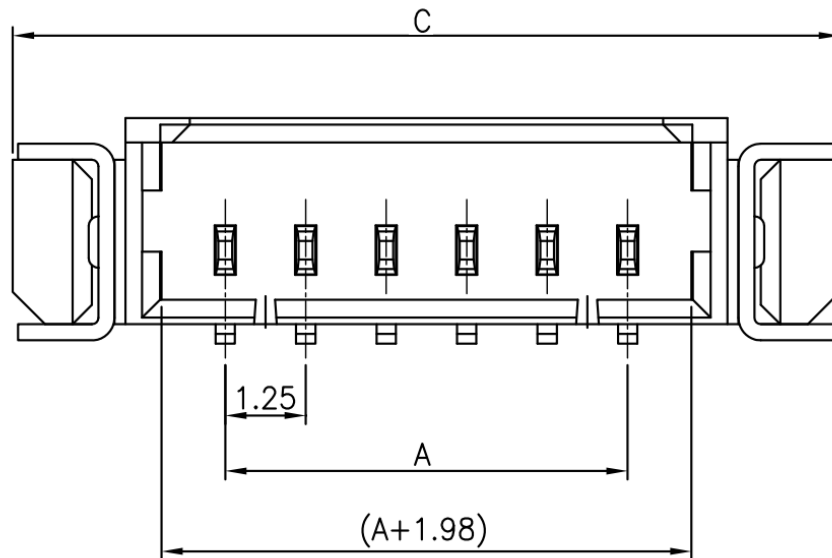

Figure 6.2 Dimensions of a 7-pin port socket

Part No.	Dimensions (mm)	
	A	C
7 Pin	7.50	14.10

7 USB Cable Requirements

7.1 USB Type-A cable

The total length of the USB cable is recommended to be 1.2 meters/4 feet or less. The wire needs to be shielded and the braiding number is 64 or more. The D+/D- data cable needs to be twisted and uses a 26AWG wire. The wire is on the side of the module with a magnetic ring. The reference design diagram is in the figure 7.1 below.

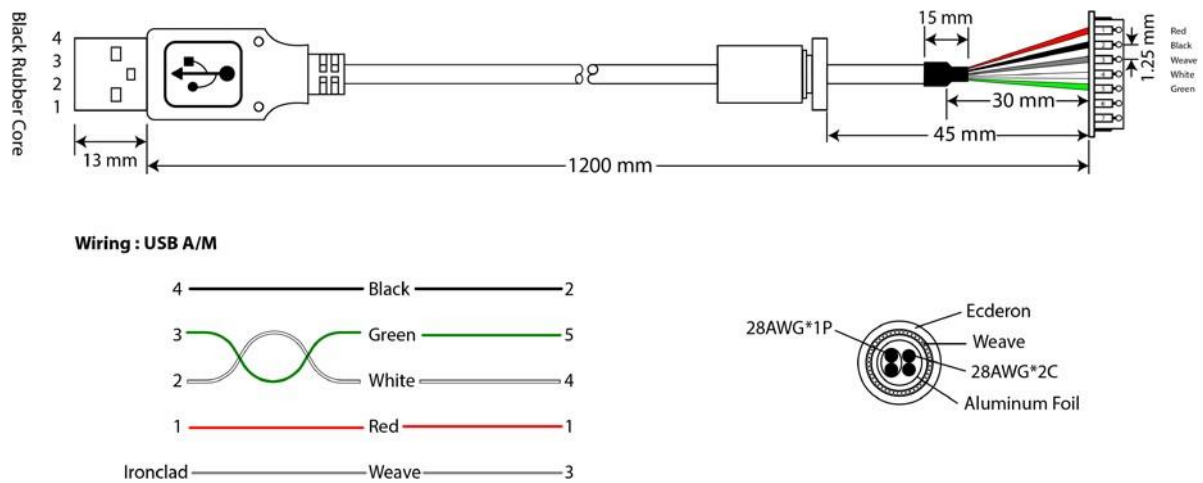

Figure 7.1 Cable Interface

7.2 Plug Wire

It is recommended that the USB signal cable D+/D- twisted-pair uses a 26AWG wire. The total length of the double-plug wire must not be more than 15cm. With a shielding layer, the number of weaves is 64 or more to enhance the anti-interference of the USB cable. The reference design diagram is shown in Figure 7.2.

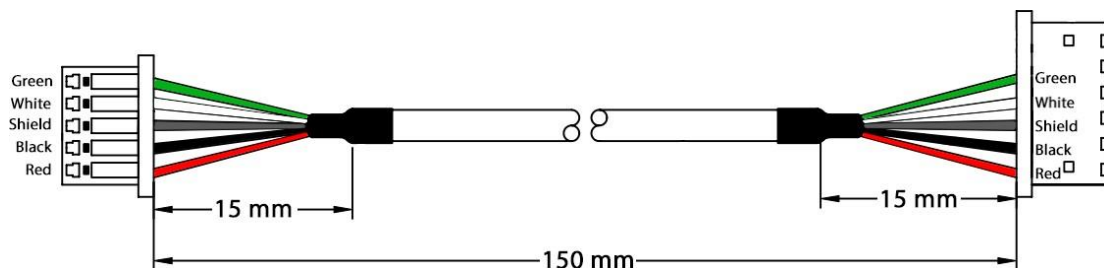

Figure 7.2 Plug Interface

8 Design Guide

8.1 Front Lens Design

- The front of the module is recommended to take glass or acrylic transparent material, which requires a transmission rate of more than 85 % within 400nm to 900nm wavelength range.
- The aperture size of the transparent material in front of the lens is recommended to be 4mm-7mm, as shown in the figure below, and the middle two lens holes are recommended to use a circular hole design with a diameter of 6.6mm.
- The aperture size of the transparent material in front of the Near-Infrared fill light is recommended to be 12mm-15mm, as shown in the figure below, and it is recommended to use a circular hole design with a diameter of 12mm.

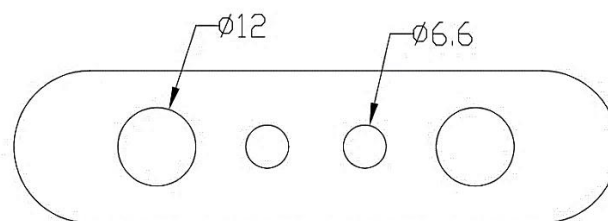

Figure 2.1 Schematic diagram of Acrylic Transparent Holes

- It is recommended to shade the front of the module, except for the position of the lens and the near-infrared LED corresponding to the transparent circular hole, to reduce the effect of stray light on image acquisition.
- As shown in the diagram below, there is a 0.5mm spacing between the lens and the transparent material in front to allow module size variance and avoid lens focusing errors in module assembly.

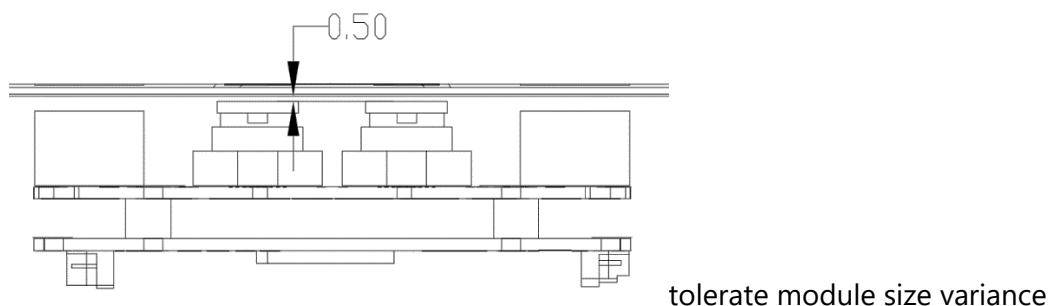

Figure 8.2 Schematic diagram of the distance between the lens and the front transparent material

- It is recommended to add the shading treatment around the lens and use the foam to isolate stray light.
- The foam is in close contact with the front glass or acrylic to reduce the effect of stray light on image acquisition, as shown below.

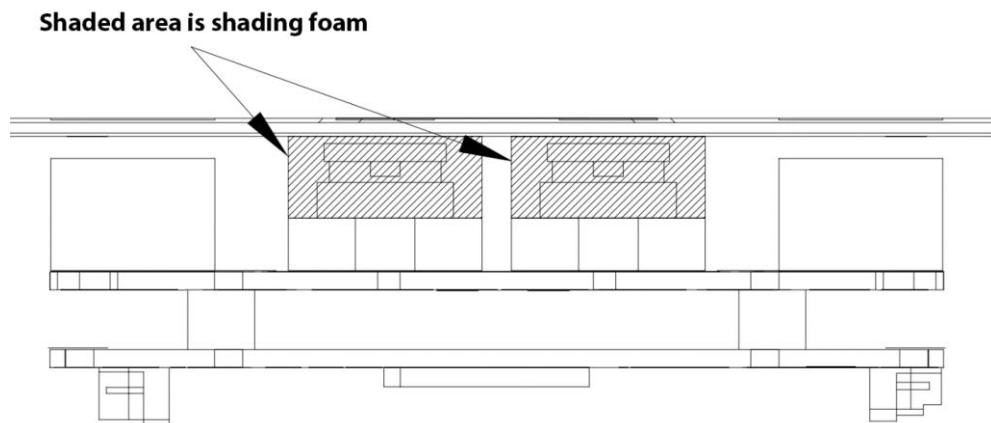

Figure 8.3 Schematic diagram of Foam Shading design

8.2 Heat Dissipation Design

- It is recommended to take the heat dissipation method. The surface of the CPU chip and the heat sink (or the metal shell of the device) are kept in close contact by thermal conductive silicone pad.
- The thickness of the thermal conductive silicone pad is recommended to be less than 3mm. The schematic diagram of the conductive heat treatment is shown below.

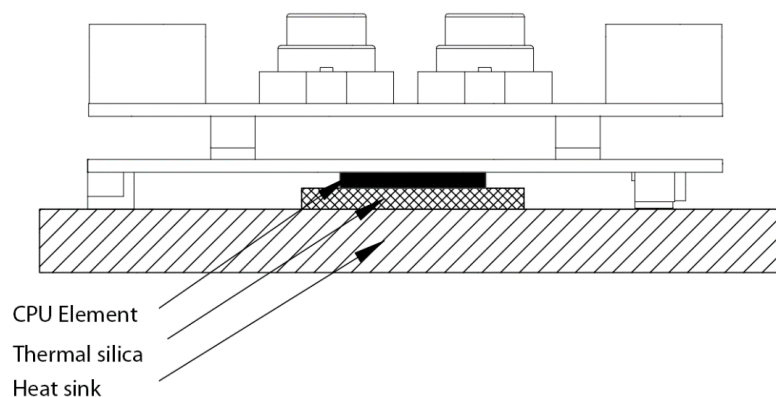

Figure 8.4 Schematic diagram of conductive heat treatment

9 Installation Guide

9.1 Installation Method

The screw holes at the four corners of the module as shown below are used to fix the module with the hole diameter of 2.0 mm, as shown in Figure 9.1.

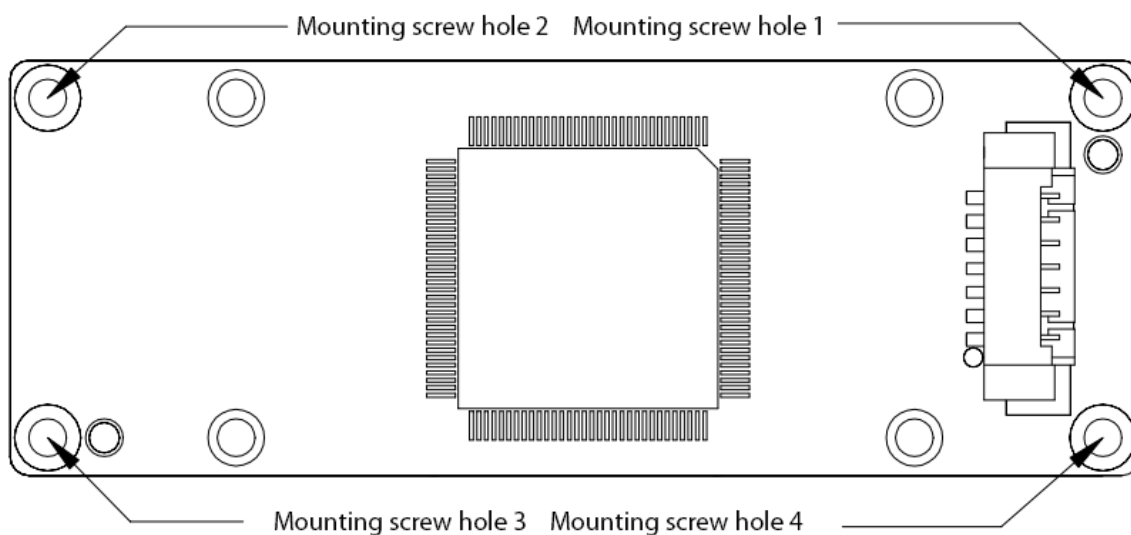

Figure 9.1 Location of the mounting holes in the module

- The module has a positioning hole with an aperture of 1.6 mm, as shown below:

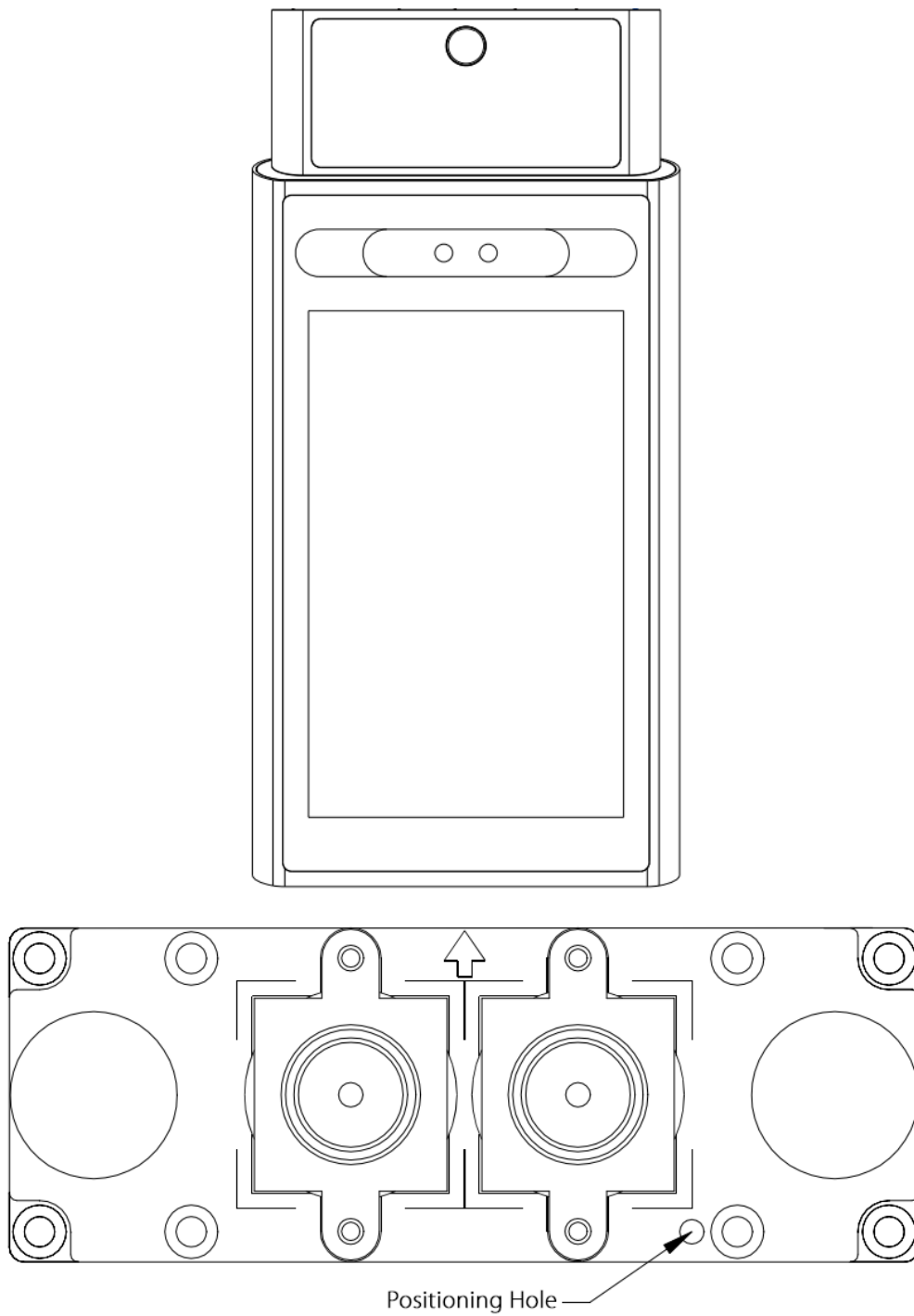

Figure 9.2 Location of Positioning hole in the module

- Once the module is installed inside the metal case, the screw hole of the module needs to be aligned with the metal case with fixed screws.
- To avoid any damage to the module, the metal casing should not contact other part of the module.

9.2 Vertical Mount Approach

The plane where the lens is located (or the lens plane) should be perpendicular to the horizontal direction:

- The recommended installation height is 1.55 meters, and the recognition distance is between 0.4 - 0.8 meters.
- This can be adapted to the height range of 1.47m to 1.82m, as shown below.

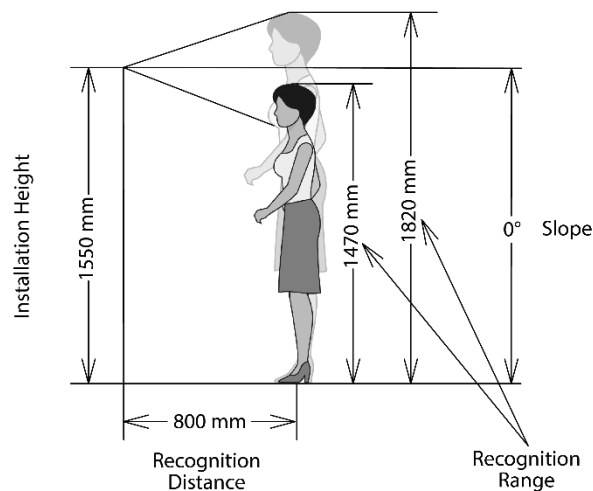

Figure 9.3 Schematic diagram of the installation height of 1.55 m

9.3 Tilting Mount Approach

- The recommended installation height is 1.2 meters or 48 inches, and the tilt angle is 37 degrees (that is, the angle between the plane above the lens and the vertical direction is 37 degrees), and the recognition distance between 0.4 to 0.8 meters.
- This can adapt to the height range of 1.5m to 2.2m, as shown in the below image.

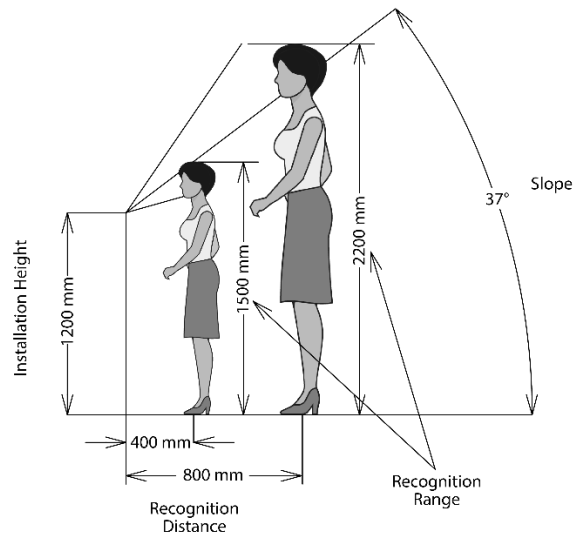

Figure 9.4 Schematic diagram of the installation height of 1.2 meters

9.4 Recommended Installation Height and Mounting Angle

- As shown in the table below, the listed mounting angle is the angle between the centre axis of the lens and the horizontal ground (that is, the angle between the plane above the module lens and the vertical direction).
- And the installation height is the distance from the module to the ground.

Height	0.8m	0.9m	1.0m	1.1m	1.2m	1.3m	1.4m	1.5m	1.55m
Angle	54°	50°	46°	43°	37°	24°	18°	8°	0°

10 Facial Expressions and Standing Posture

During enrollment and matching process, please keep natural facial expressions and proper standing postures. Incorrect facial expressions and standing postures may cause recognition failure. The guide of natural facial expressions and proper standing postures are illustrated in Figure 10.1 and 10.2, respectively.



Figure 10.1 The facial expressions illustration



Figure 10.2 The standing postures illustration

190 Bluegrass Valley Pkwy,
Alpharetta, GA 30005
E-mail: info@armatura.us
www.armatura.us

