

# Installation Guide

## Swing Barrier SBTL5000 series

Applicable Model: SBTL5000/5200, 5011/5211, 5022/5222

Version: 1.0

Date: Jan, 2018

# 1 Overview

## 1.1 Preparation

- A. **Tools:** measuring tape, adjustable wrench, impact drill and small screwdriver (included in the package).
- B. **Material:** PVC anti fire and insulation tube (diameter $\geq$ 25mm), Standard three-core power extension wire, M12 expansion screw (included).
- C. Put the connection wire of devices into tube before laying them underground.
- D. Power wire and signal wire should be set separately for distinguishing strong and weak power. It is recommended that the wiring is to be done by a professional, and the device must be connected to the ground.

**SBTL5000** installation holes and cabling positions as shown in Figure 1-1:

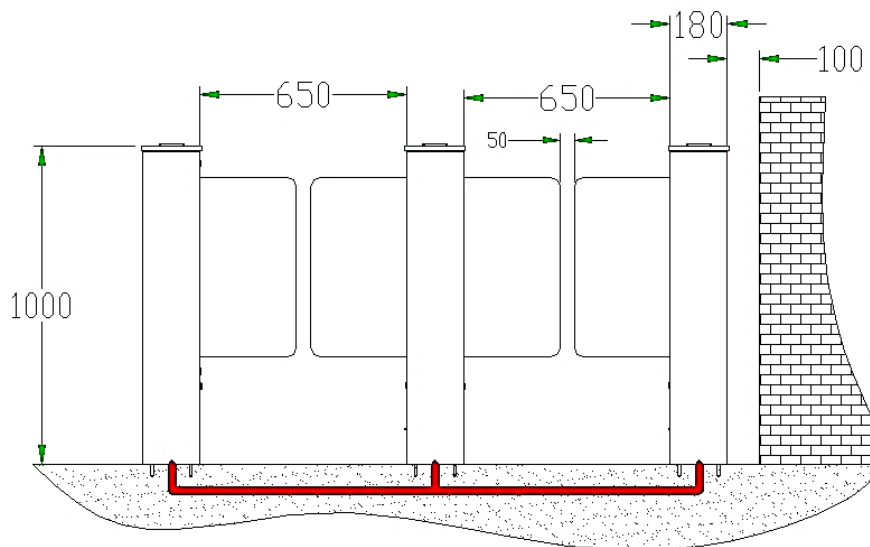

Figure 1-1

## 2 Installation

1. Drill holes based on the drawing of mount holes position, as shown in Figure 2-1. Then set the expansion screw into holes.

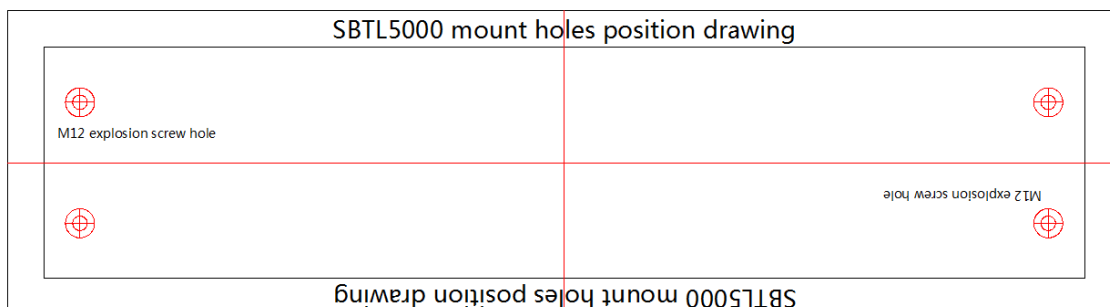

Figure 2-1

2. Pre-fixed the device by these expansion screws. Then connect the wires between master and slave devices. As shown in below:

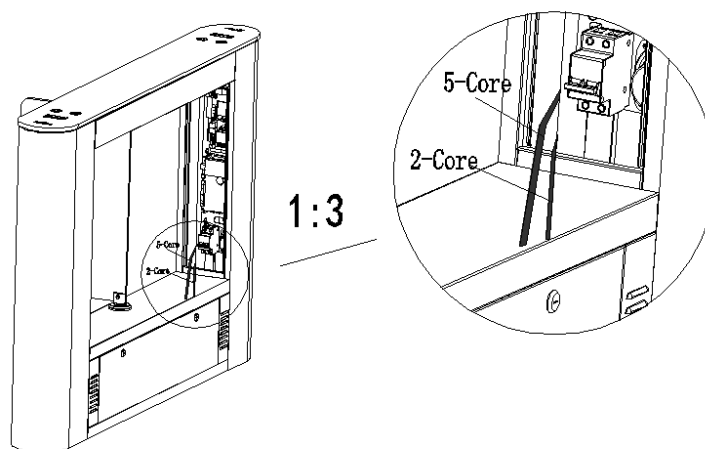

Figure 2-2 (5-core: signal, 2-core: 24V power)

3. Test with temporary cable, ensure that ground wire of AC power was connected to cabinet.
4. Turn on the air switch to test whether the device is working properly, wait for 10 seconds for the gate to complete self-test program. At the same time check whether or not the indicator light working properly. If everything is normal, you

can start the installation procedures. If an exception occurs, please contact your vendor for information.

## 3 Wiring Diagram

Check circuit according to the following wiring diagram:

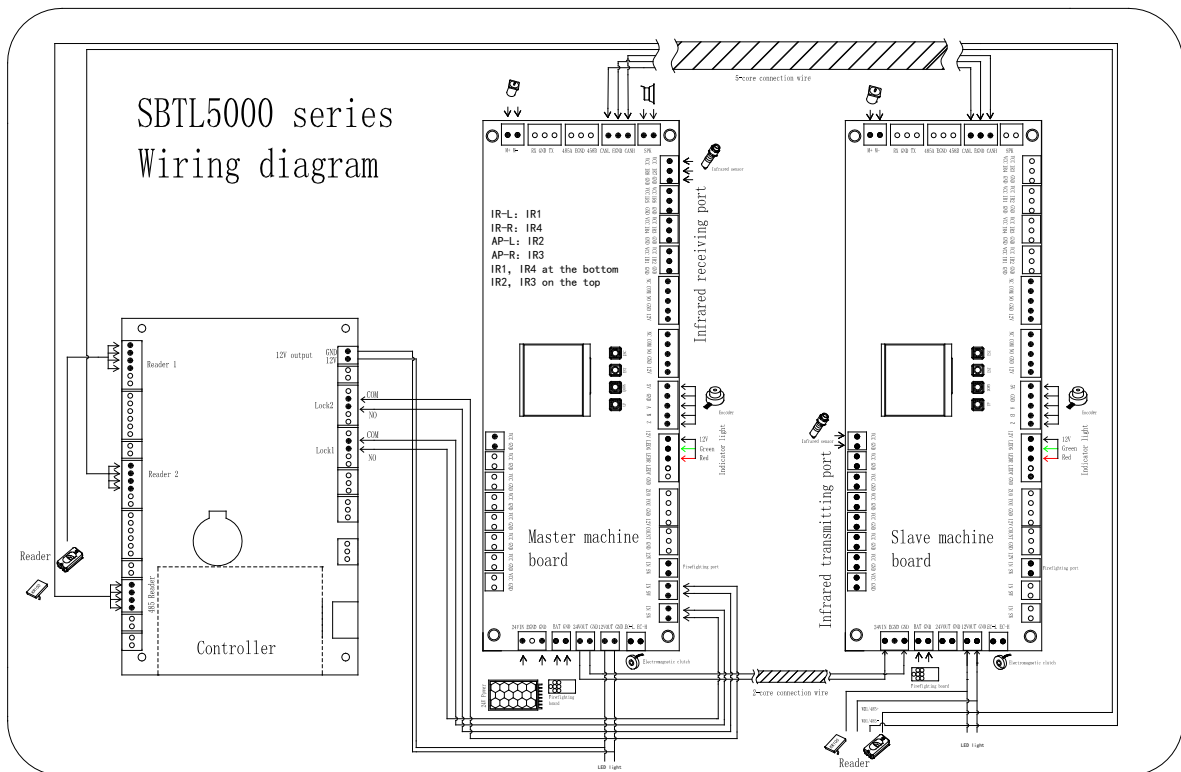

Figure 3-1

## 4 Menu Operation

### 4.1 Function of control board

- A. After connecting to power, the LCD screen on control board will displays default state, which is current Work Mode.
- B. There are 4 buttons 'UP, DOWN, ENT, ESC' below the LCD screen.

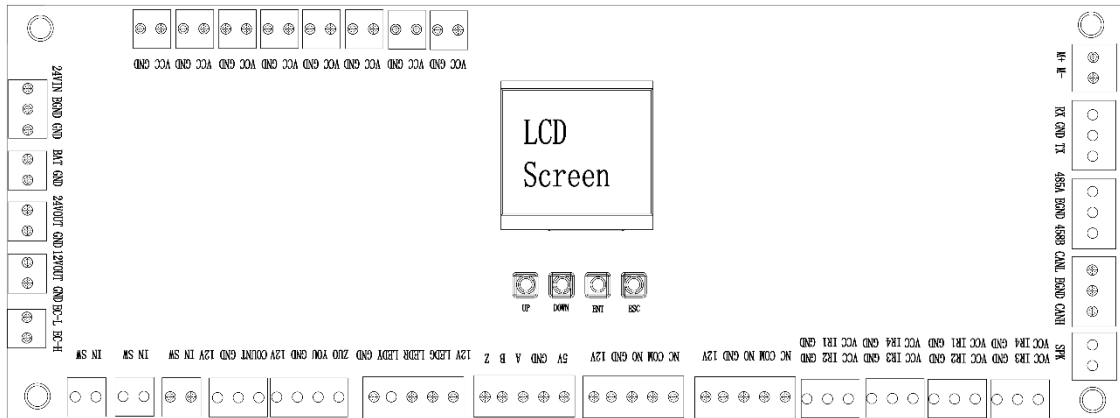

Figure 4-1

## 4.2 Button introduction

UP: to move up menu item or increase the value.

DOWN: to move down menu item or decrease the value.

ENT: to enter menu setting item or confirm the current modified value.

ESC: to return to the previous menu or to cancel the current operation.

## 4.3 Menu operation

Press the ENT button, enter the password input interface, **the default password is: 'UP, UP, DOWN, DOWN, DOWN, DOWN'**. If any step fails please press the ESC button to get back. After entering the menu press **UP** or **DOWN** to choose a menu item and then press **ENT** to enter the interface and adjust function or value.

**Attention:** The product has been inspected and debugged before sending out of factory, in order to ensure that before normal usage, the system is safe and reliable. It is also must to check the system again after installing in the field. All the above operation should be operated by professional and parameters setting of the system shouldn't be changed without permission.

## 5 Troubleshooting

Number	Failure description	Analysis and solution
1	No response from direction indicator or indication is not correct.	Check whether the connection of the roof lamp is correct or not.
2	After swiping the card, there is only a swing arm action.	Check the master and slave machine type setting and the 5-core, 2-core connection line.
3	Barrier open after a long time no closing.	Check whether the time of the opening is too long or the IR sensor is covered by others.
4	Motor doesn't rotating or the resistance too great or belt loosen.	If the motor working properly, but the rotated angle not enough, which may caused by belt loosen. If can't solve it, try to increase the value of twelfth menu.
5	When power on, the swing arm can not turn back to the initial position.	Ensure that no obstacle in the passway, then restart the equipment.