

# Quick Start Guide

## SpeedFace series

---

Version: 1.0

Date: October 2018

# Overview

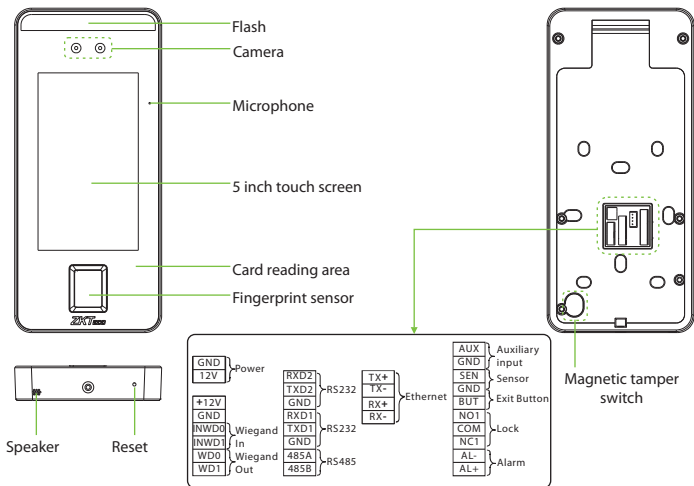

# Device Installation

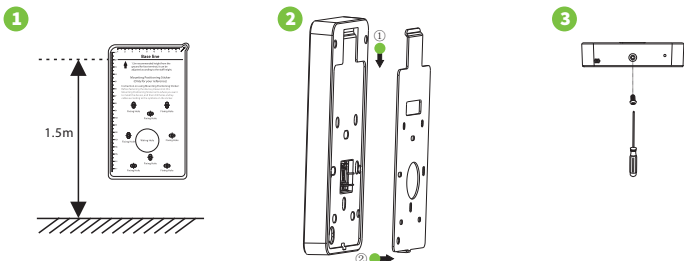

- ① Attach the mounting template sticker to the wall, and drill holes according to the mounting paper. Fix the back plate on the wall using wall mounting screws.
- ② Attach the device to the back plate.
- ③ Fasten the device to the back plate with a security screw.

# Standalone Installation

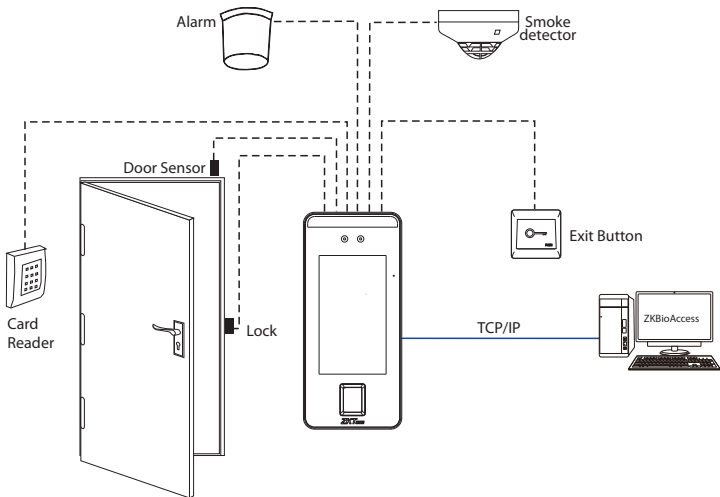

Note: In this document, we only guide you to connect some common components, if you want more guidance on connection of SRB, external fingerprint reader and so on, please refer to user manual document.

# Door Sensor, Exit Button & Alarm Connection

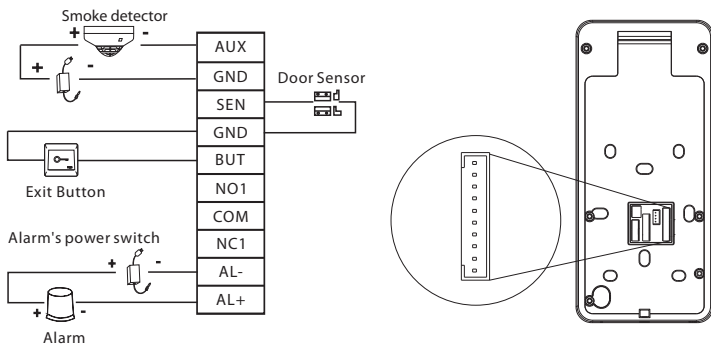

# Lock Relay Connection

The system supports Normally Opened Lock and Normally Closed Lock.

The NO LOCK (normally opened at power on) is connected with 'NO1' and 'COM' terminals, and the NC LOCK (normally closed at power on) is connected with 'NC1' and 'COM' terminals. Take NC Lock as an example below:

## 1) Device not sharing power with the lock

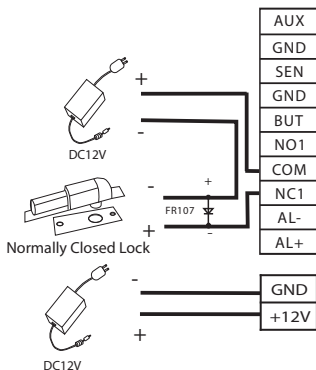

## 2) Device sharing power with the lock

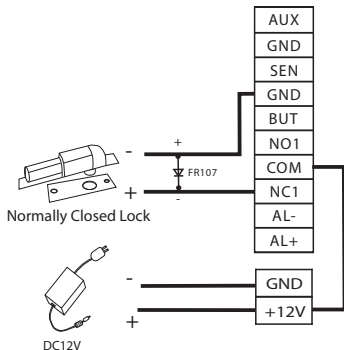

## RS485 and RS232 Connection

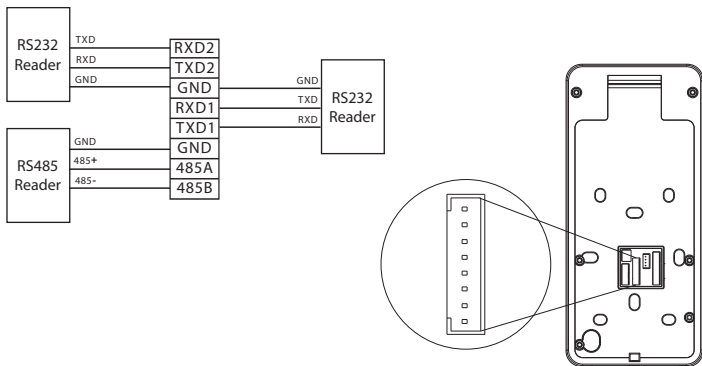

## Wiegand Input Connection

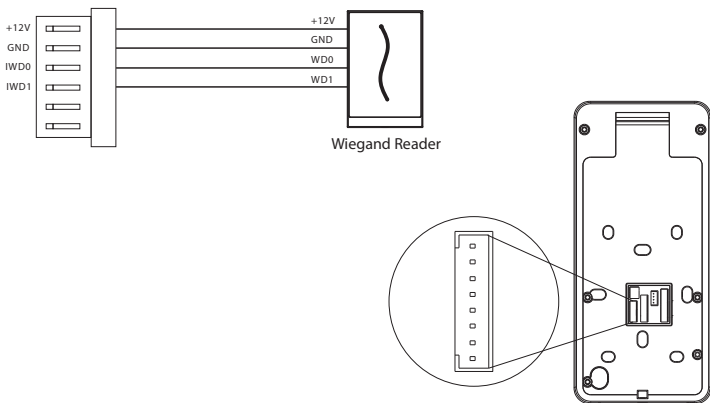

## Power Connection

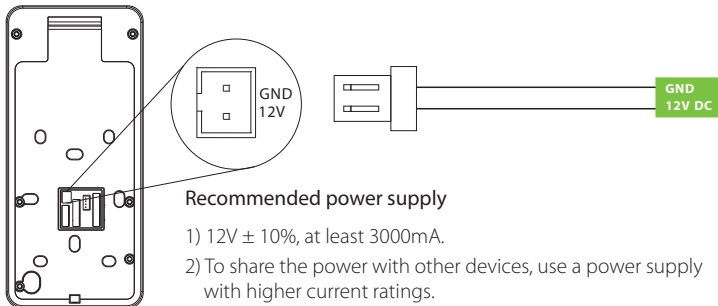

## Ethernet Connection

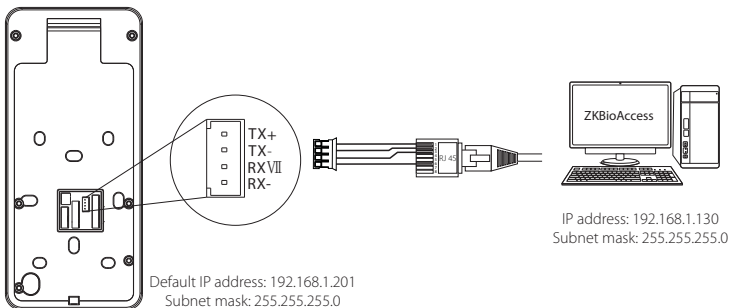

Click [Settings] > [Network Settings] > [TCP/IP Settings] > [DHCP], input the IP address and click [OK].

Note: In LAN, IP addresses of the server (PC) and the device must be in the same network segment when connecting to ZKBioAccess software.

# Quick Start

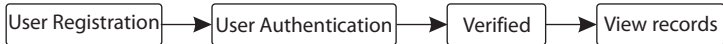

## ❖ User registration

### Register on the device

Click > Employee > to register new employee. Enter employee name, ID, register fingerprint, face, badge number (ID and Mifare card are optional), and password.

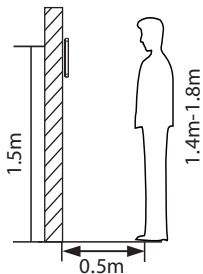
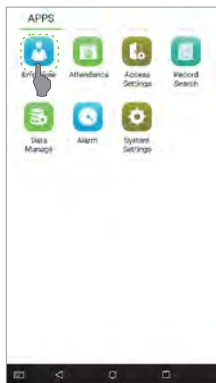
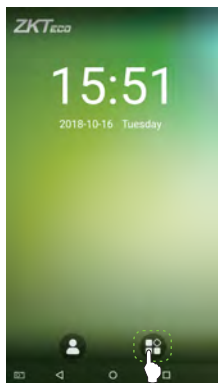

Note:

1. It's recommended to register multiple administrators.
2. It's recommended to enroll user's face in 0.5m distance for person with 1.4~1.8m height .

## Register on the software

Please set the IP address and cloud service server address on the device.

1. Click [Access] > [Access Device] > [Device] > [Search Device] to add the device to the software.

When the device has set the server address and port, it can be added automatically.

The screenshot shows the 'Search Device' window with the following details:

- Step 1:** Points to the 'Search Device' button at the top.
- Step 2:** Points to the 'Total Progress' bar, which is at 100%.
- Step 3:** Points to the 'Add' button in the 'Operations' column of the device list.
- Step 4:** Points to the 'OK' button in the 'Add' dialog box.

The 'Add' dialog box contains the following fields and options:



- Device Name\*: 192.168.214.9
- Communication Password: [Empty]
- Area\*: Area Name
- Add to Level: [Dropdown menu]
- Clear Data in the Device when Adding:
- Warning: [Clear Data in the Device when Adding] will delete data in the device (except event record), please use with caution!
- Buttons: OK, Cancel

2. Click [Personnel] > [Person] > [New] to register users in the software.

3. Add users to access levels.

4. Click [Access] > [Device] > [Device Control] > [Synchronize All Data to Devices].

For more details, please refer to the ZKBioAccess User Manual.

Note: The icons  or  in the standby interface indicates that the network connection or the server is abnormal. Please check the network cable and network connection.



## Register on the phone

Once ZKBioAccess software installation, users could enroll face via browser application on their own mobile phone.

Login onto [http://\[Cloud server IP address\].\[Server port\]/app/v1/adreg](http://[Cloud server IP address].[Server port]/app/v1/adreg) with mobile phone browser application to register users.

The users will display in [Personnel] > [Temporary Personnel], click [Review].

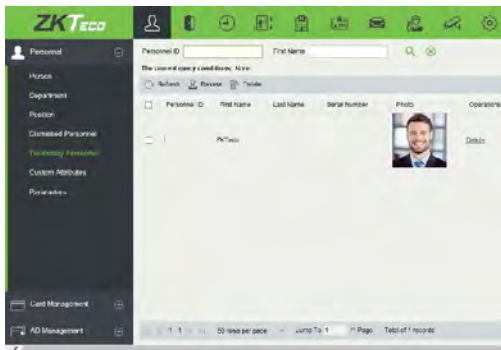
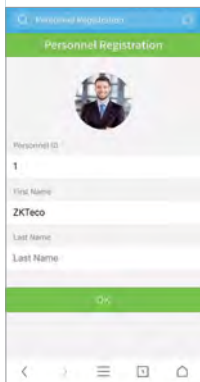

## ❖ User Authentication

Terminal could detect face in 0.3m to maximum 3m distance. The device switches to face verification interface automatically once it detect bright of environment change. The verification result shows as right image.

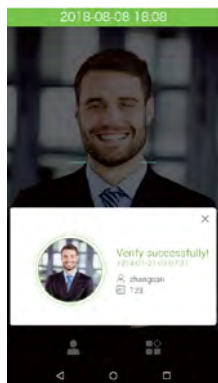

Verification is successful

## View records

### View records in the device

Click **Record Search** > **Att Log** enter **Name** or **Employee ID** (if user ID field is empty, records of all users will be displayed) > select **Time Range** > press **OK**, the corresponding attendance logs will be displayed.

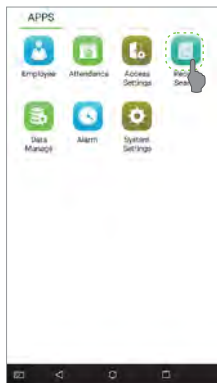

### View records on the software

Click [Access] > [Report] on the software to view the records.

# Appendix

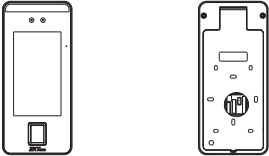
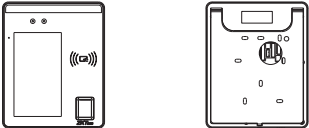
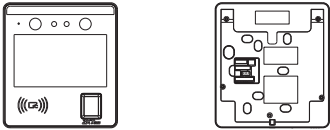
Device name	Appearance
SpeedFace V5	 The image shows two line drawings of the SpeedFace V5 device. On the left is the front view, featuring a large rectangular display area, two small circular sensors at the top, and a small rectangular component at the bottom. On the right is the back view, showing a central circular lens, several small rectangular components, and mounting points at the corners.
SpeedFace H5	 The image shows two line drawings of the SpeedFace H5 device. The front view on the left has a large display, two sensors at the top, a Wi-Fi symbol on the right side, and a small component at the bottom. The back view on the right shows a central lens, a Wi-Fi symbol, and various internal components.
SpeedFace T5	 The image shows two line drawings of the SpeedFace T5 device. The front view on the left features a large display, four sensors at the top, a Wi-Fi symbol at the bottom left, and a small component at the bottom right. The back view on the right is more complex, showing a central lens, multiple rectangular components, and various mounting points.

ZK Building, Wuhe Road, Gangtou,  
Bantian, Buji Town, Longgang  
District, Shenzhen China 518129  
Tel: +86 755-89602345  
Fax: +86 755-89602394  
[www.zkteco.com](http://www.zkteco.com)

