

QUICK START GUIDE

Applicable Model: G4

Version: V1.0
Date: Oct 2018



ZKT Building, Wuhe Road, Gangtuo, Bantian, Buji Town, Longgang District, Shenzhen China 518129
Tel: +86 755-89602345
Fax: +86 755-89602394
www.zkteco.com



© Copyright 2018, ZKTeco is a registered trademark of ZKTeco or related company. All other product and company names mentioned are used for identification purposes only and may be the trademark of their respective owners. All specifications are subject to change without notice. All rights reserved.

Safety Precautions

Before installation, please read the following precautions carefully to prevent risks and dangers to this product, users and any other person.

- Do not expose to direct sunlight, water, dust and soot.
- Do not place any magnetic objects near the product. Magnetic objects such as magnets, CRT, TV, monitors or speakers may damage the device.
- Do not place the device next to any heating equipment.
- Prevent water, drinks or chemicals leaking into the device.
- This product is not intended for use by children unless they are supervised.
- Do not drop or damage the device.
- Do not disassemble, repair or modify the device.
- Do not use the device for any purpose other than those specified.
- Remove dusts or dirt regularly. While cleaning, wipe dust off with a smooth cloth or towel instead of water.

Contact your supplier in case of any problem!

User Registration

1) Recommended distance

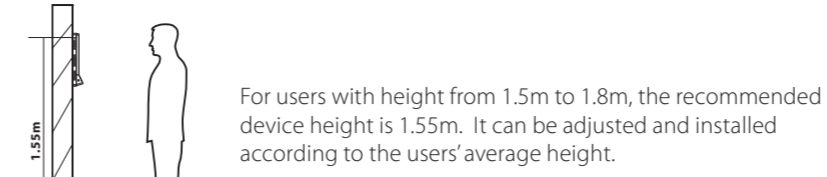

The recommended position

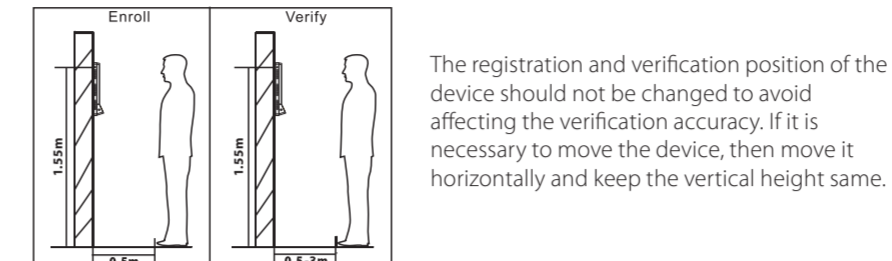

2) The recommended and not-recommended facial expressions:

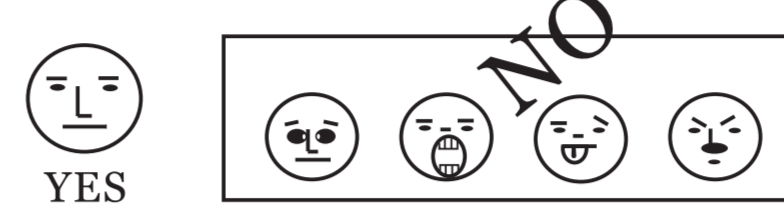

User Registration

3) Registration

During registration, please adjust your position and keep your face inside the green frame.

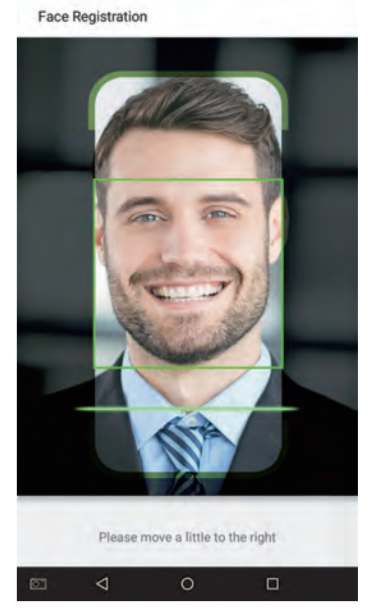

Device Overview

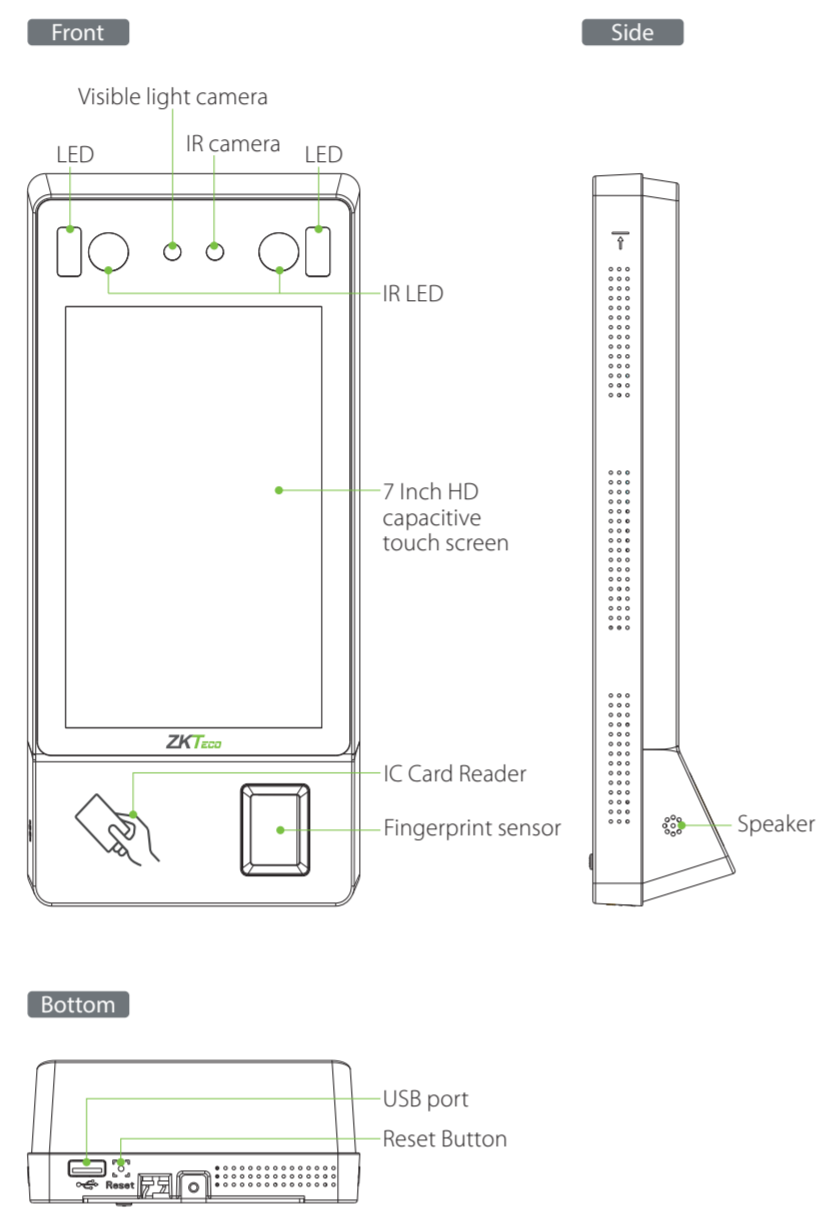

Device Overview

Product PIN Diagram

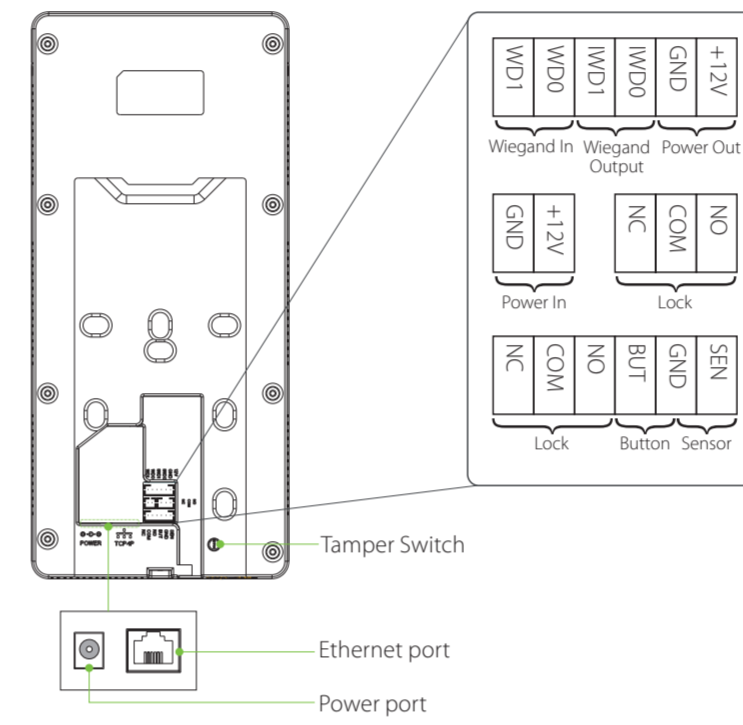

Product Dimensions

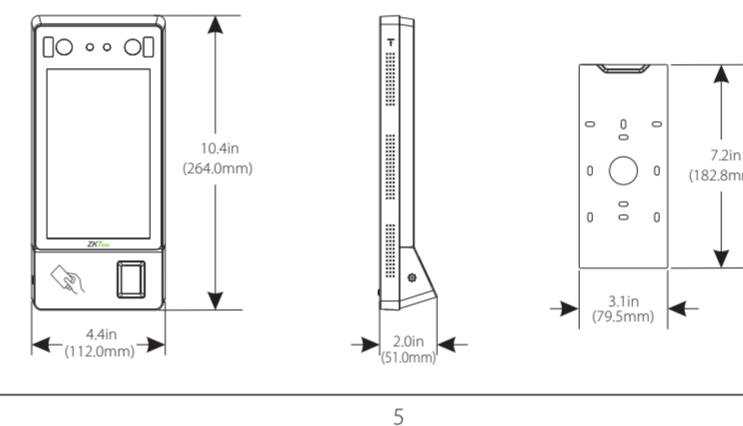

Product Installation

Mounting the device on wall

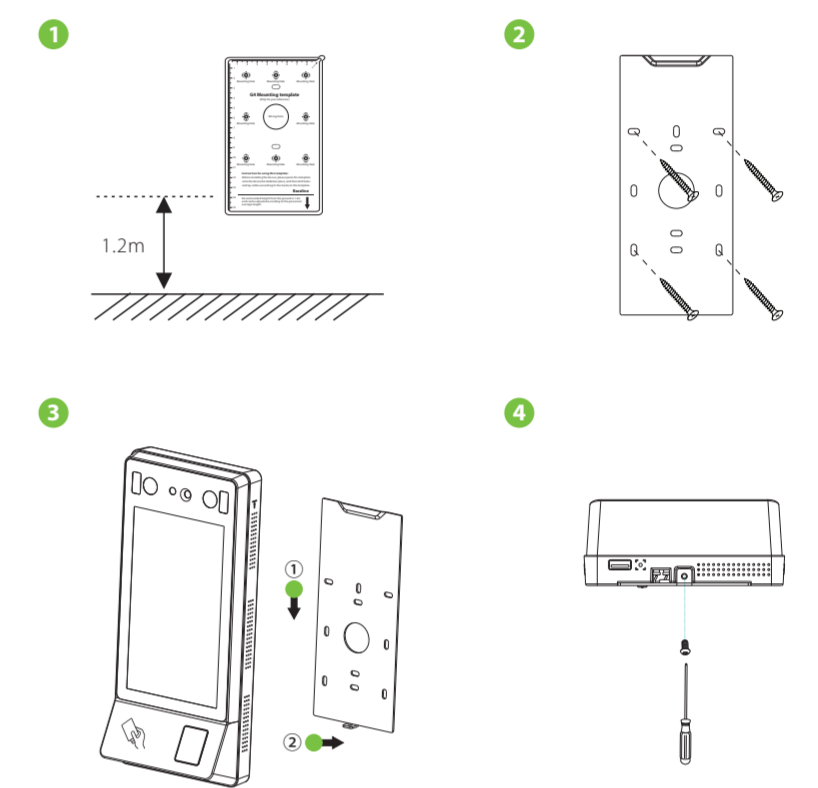

- 1 Paste the mounting template sticker onto the wall, and drill holes according to it.
- 2 Fix the back plate to the wall with wall mounting screws.
- 3 Attach the device to the back plate.
- 4 Fasten the device to the back plate with a security screw.

Ethernet & Power Connection

LAN Connection

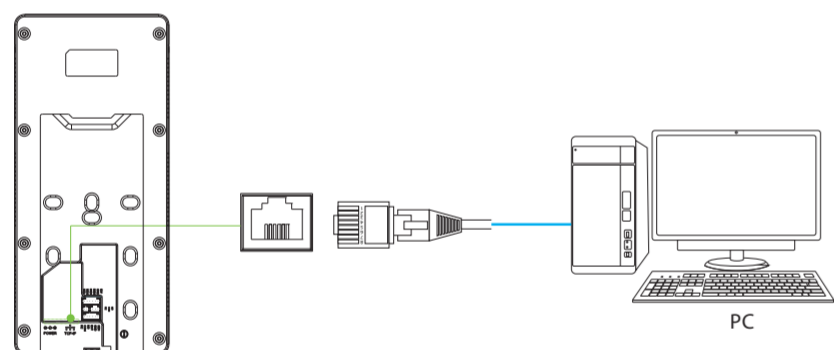

Power Connection

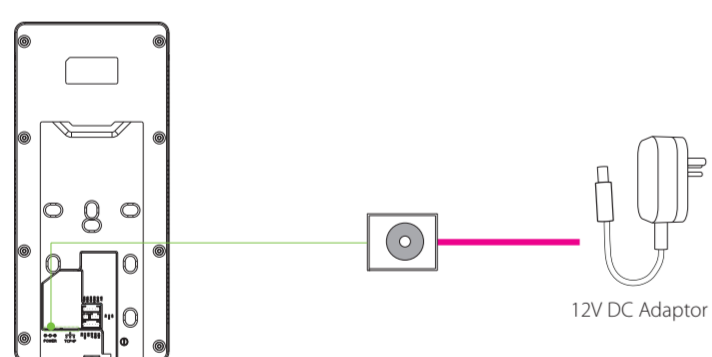

Recommended power supply

- Rating of 12V and 3A
- To share the device's power with other devices, use a power supply with higher current ratings.

Lock Relay Connection

The system supports Normally Opened Lock and Normally Closed Lock. The diagrams shown hereafter represents Normally Closed Lock.

Device not sharing power with the lock is shown below:

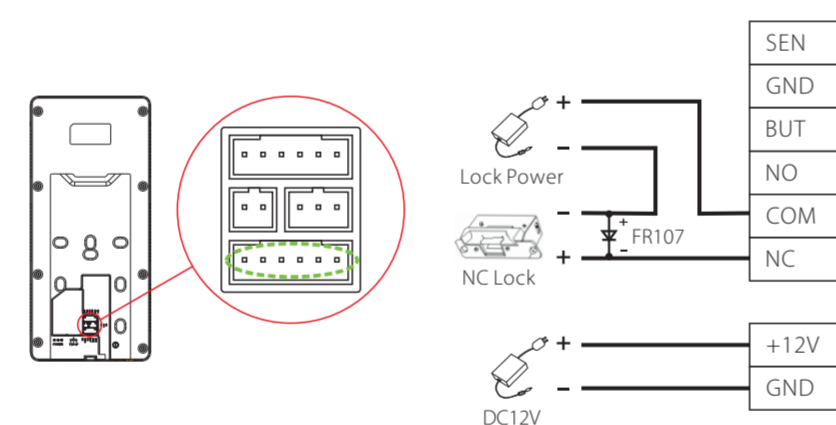

Device sharing power with the lock is shown below:

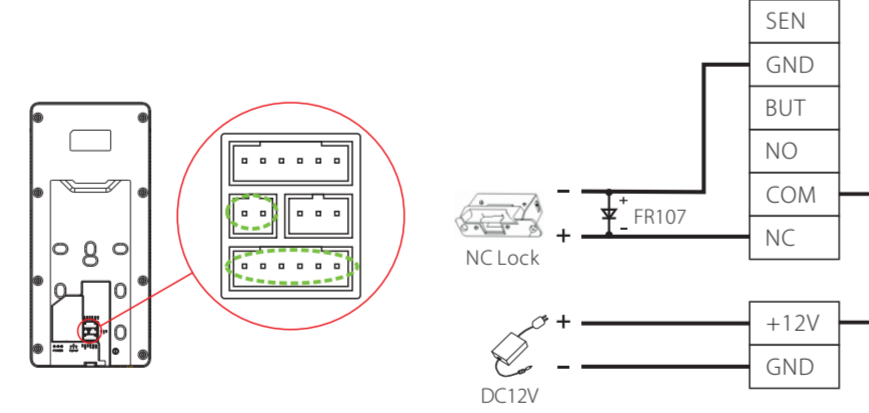

Connecting Other Devices

Button & Sensor Connection

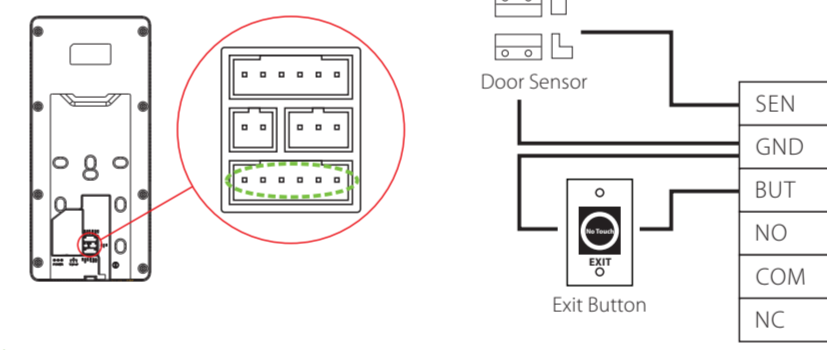

Alarm Connection



Wiegand Connection

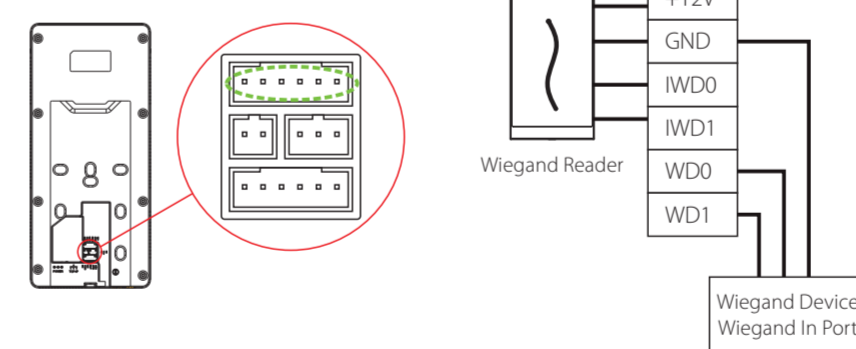

Standalone Installation

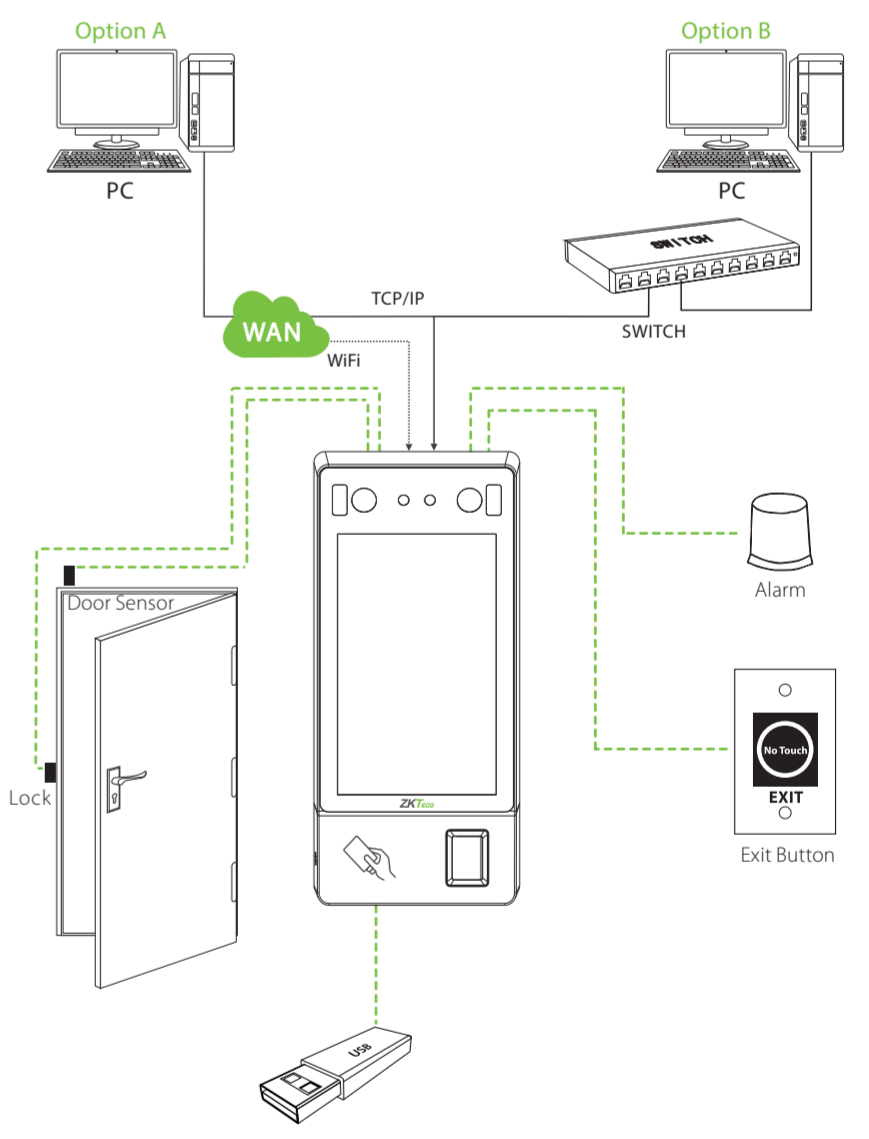

Menu Functions

Enroll New User

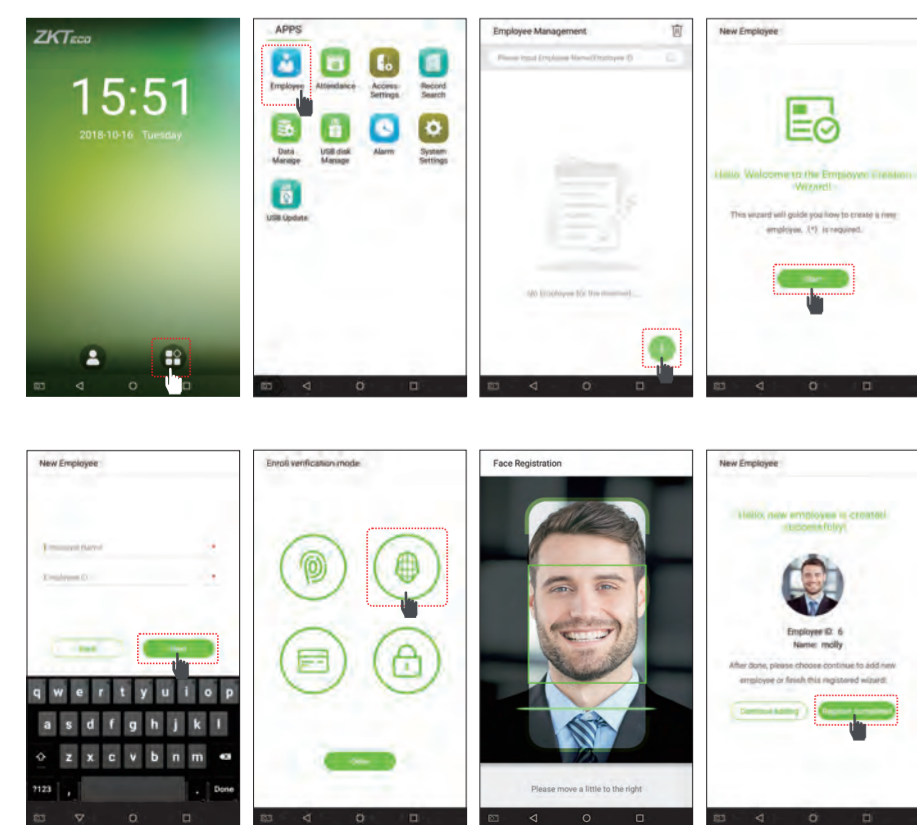

Go to Main Menu > **Employee Management** > **New Employee** > **Enroll verification mode**. Settings include entering Employee Name, ID, choosing User Role (Normal User is not authorized to operate the menu options of the device. Super Admin can operate all the menu options of the device), registering Fingerprint, Face Registration, Enroll Badge Number (ID and Mifare card are optional), and setting Password.

Menu Functions

Access Settings

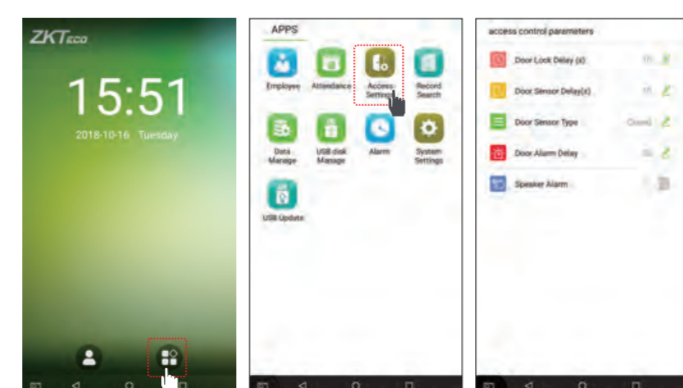

Go to Main Menu > **Access Settings** > **Access control parameters** to enter **Access control parameters** setting interface.

Network Settings



Go to Main Menu > **System Settings** > **Network Settings**, set the IP Address. The device will communicate with PC via the Ethernet parameters. Using Cloud Service Settings sets Server Address and Server port according to the server.

Menu Functions

Record Search



View records in the device:
Go to Main Menu > **Record Search** > **Att Log** enter **Name** or **Employee ID** (if user ID field is left blank, records of all users will be displayed) > select **Time Range** > press **OK**, the corresponding attendance logs will be displayed.

View records on computer:

Go to Main Menu > **USB disk Management** > **USB disk Download**. Insert the USB disk correctly and download the data to the USB drive, then copy this data from the USB drive to your PC. The downloaded data filename will be "Device Serial Number.dat", you can open and view it.

Menu Functions & Troubleshooting

Date and Time Settings

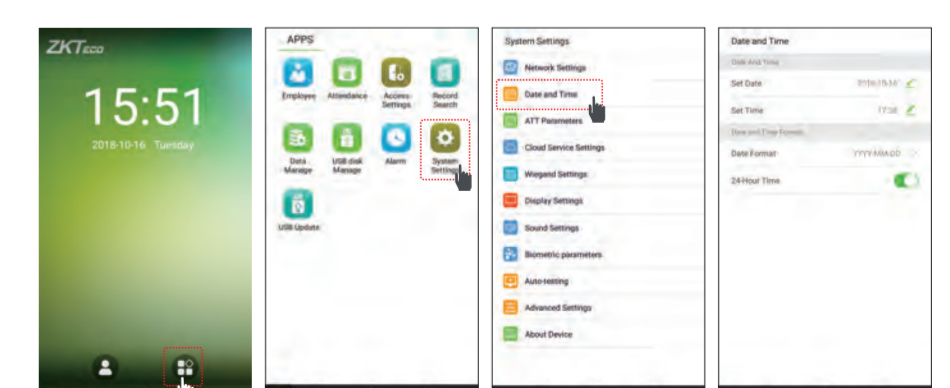

Go to Main Menu > **System Settings** > **Date and Time**, to enter **Date and Time** setting interface.

Troubleshooting

1. **Fingerprint cannot be detected or it takes too long.**
 - Check whether the finger or fingerprint sensor is stained with sweat, water or dust.
 - Retry after wiping the finger and fingerprint sensor with dry paper tissue or a mildly wet cloth.
 - If the fingerprint is too dry, blow the finger and retry.
2. **Failed to gain access after successful verification.**
 - Check with administrator whether the enrolled fingerprint has been deleted from the device.
3. **Door does not open after successful verification.**
 - Check if the lock open duration parameter is set appropriately.