

Quick Start Guide

FaceKiosk-H13A/C

Version: 2.1

1. Components

Wall Mount Facekiosk-H13A

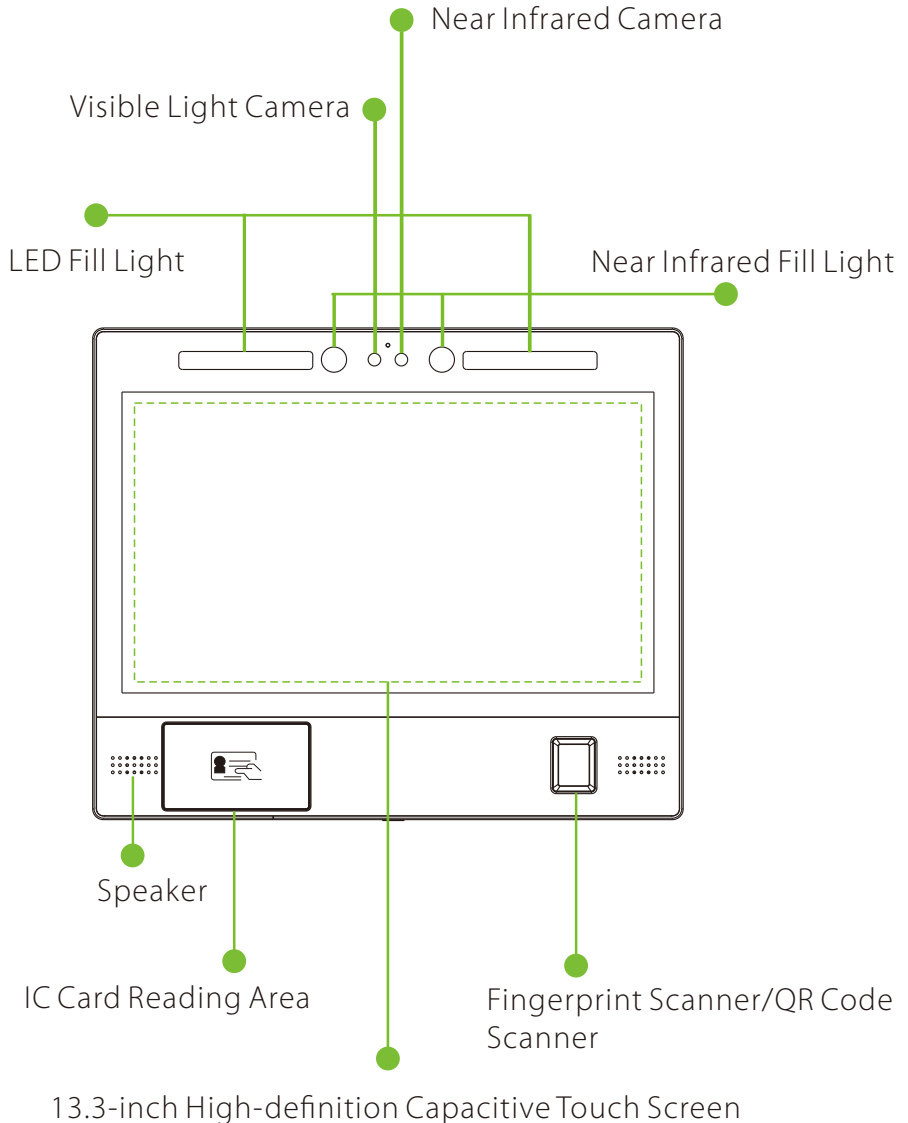

Floor Mount Facekiosk-H13C

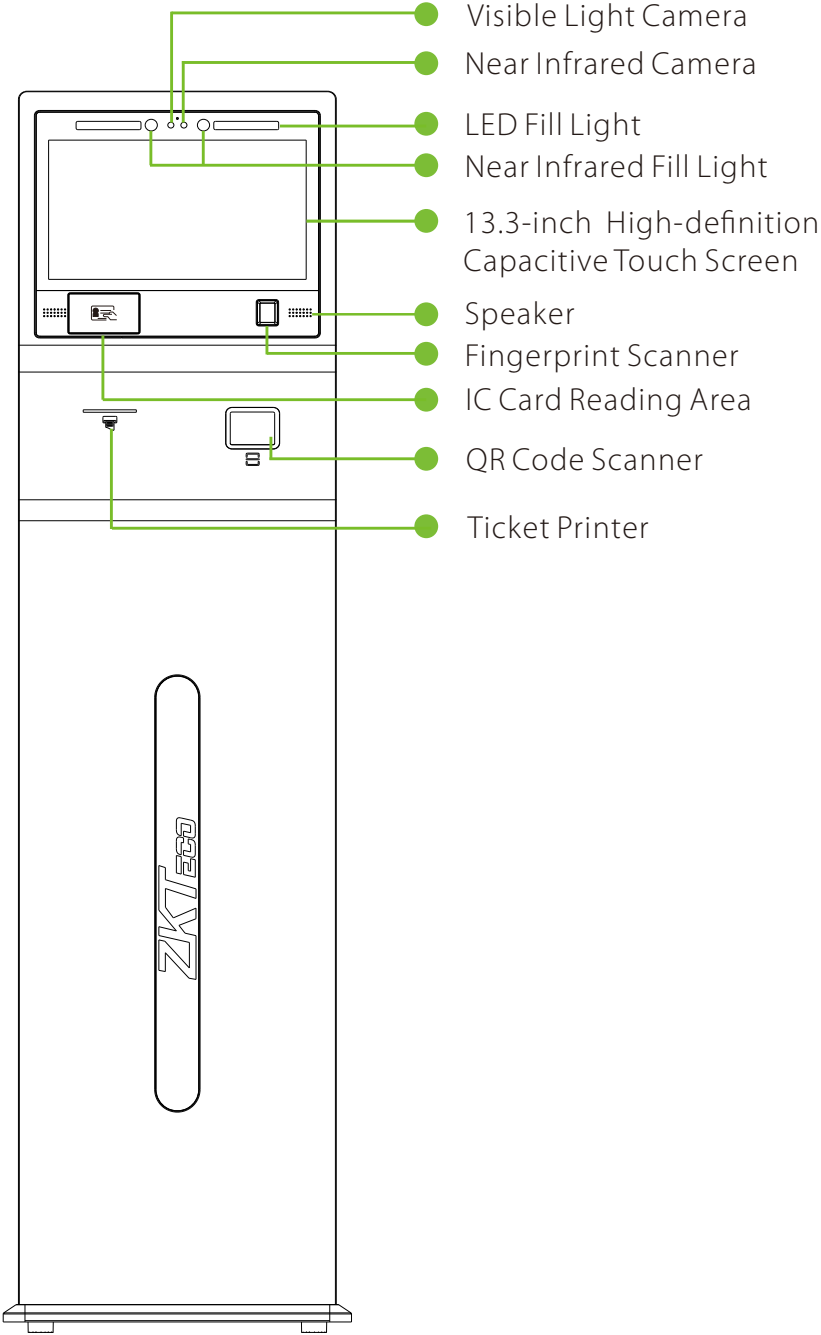

2. Installation Procedure

❖ Wall Mount Installation Procedure

Before installation, connect the wire to the device and move it through the device's lower aperture.

- 1 Align the backplate to the screw holes on the back of the device.

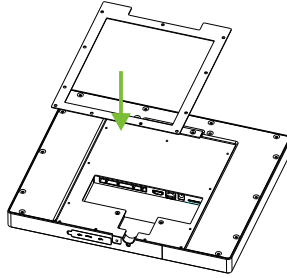

- 2 Secure the plate with the screws (11 pcs) to the back of the unit.

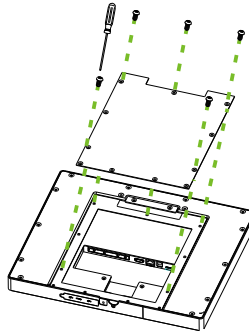

- 3 Place the rear panel at an appropriate height from the ground. Drill the holes on the wall and fix it.

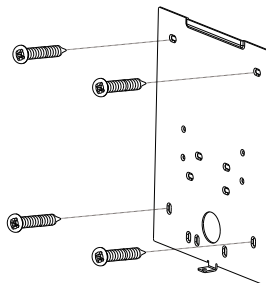

- 4 Set the device at the desired position on the rear panel that is fixed on the wall.

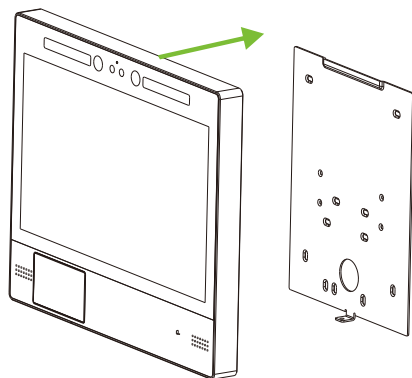

- 5 Secure the Kiosk by assembling the device and the rear panel with the bottom screw.

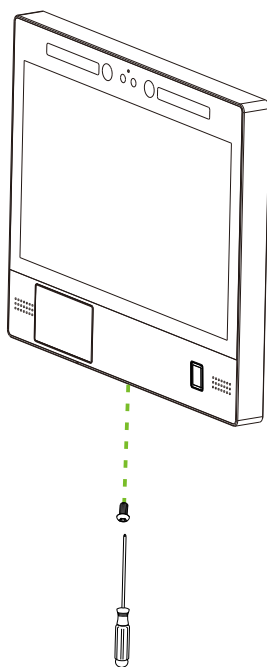

❖ Floor Mount Installation Procedure

- 1 Take the device and the base from the box. Fix the device into the corresponding slot of the base plate.

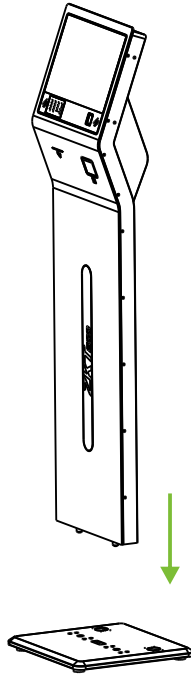

- 2 Cautiously incline the device horizontally and assemble the device over the base with the screws (8 pcs) from the bottom of the base.

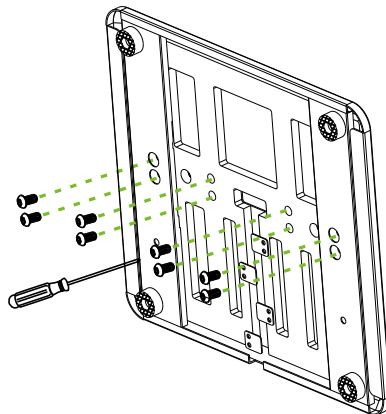

3. Door Sensor, Exit Button & Alarm Connection

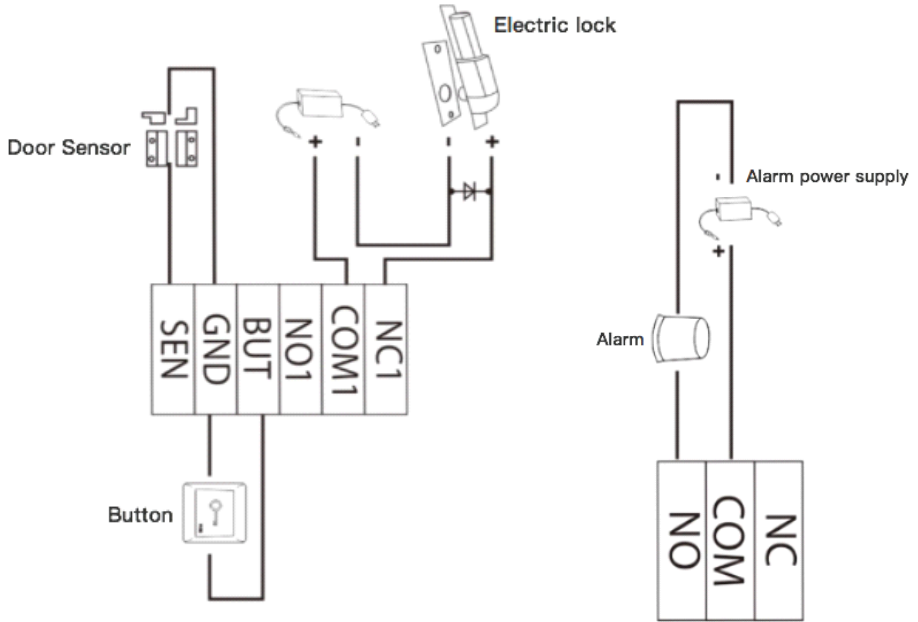

4. Access Control Device Connection

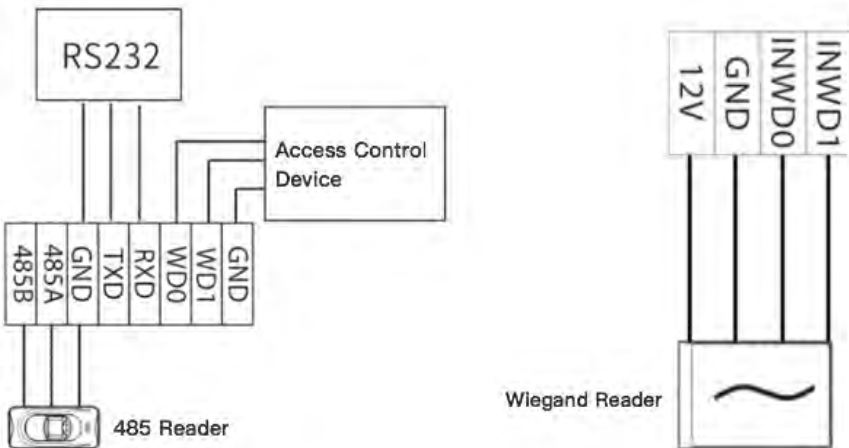

5. Operational Procedure

❖ Visitor Self-registration Methods



1 Register on the reception desk device.



2 Scan the QR code to register via Mobile phone.

Note:

The visitor can register by scanning the QR code on the reception desk device or the QR code on the invitation E-mail sent by the system in advance.

❖ Process Overview

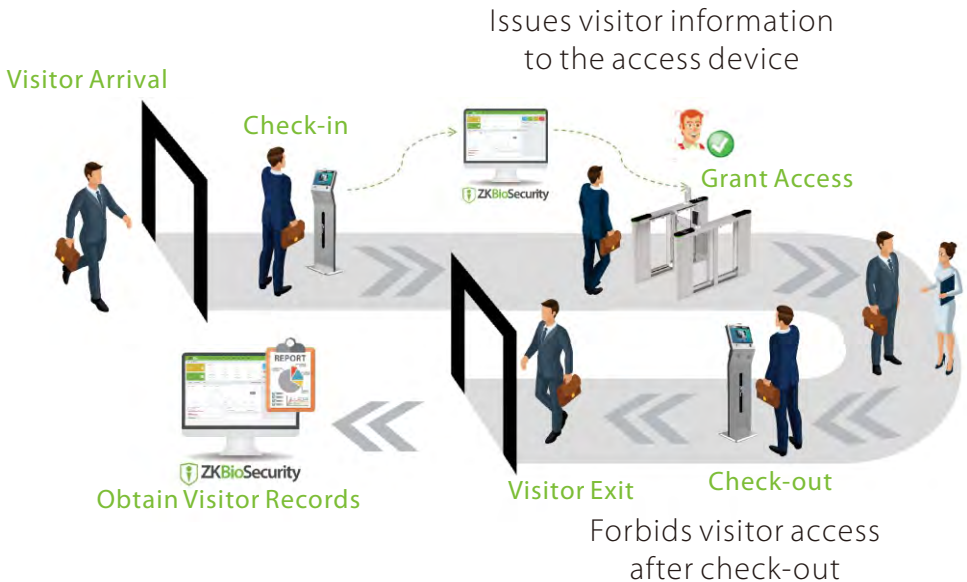

6. Install and Uninstall Firmware

1. Install the Firmware via U Disk

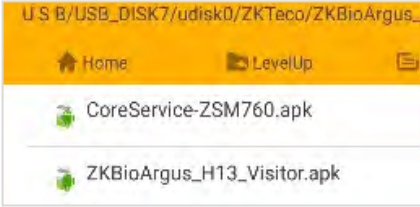

Step 1: Install the **CoreService** APK first.

Step 2: Then, install the **ZKBioArgus** APK.

2. Clear the Data and Uninstall the Firmware

Click Firmware System Settings > Personality Settings> Android System Settings.



ZKBioArgus CoreService



1. Uninstall both the Coreservice and ZKBioArgus APK'S.
2. Uninstall the ZKBioArgus first.

3. Delete the Config and ZKTeco Folders

1. In the Android Interface, select Explorer > Internal Memory > Delete.
2. Delete the two Folders **Config** and **ZKTeco**.



7. Software Basic Settings



Internet



ZKBioSecurity

After completing the following five simple steps, the device will be ready to use for visitor management.

1 Set the Server details on device.

E.g: http://110.80.38.74:8658

Server Address: 110.80.38.74

Communication Port: 8158

Server Port: 8658

Server Type	ZKBioSecurity >
Domain Name Server	<input type="checkbox"/>
Server Address	110.80.38.74 ✓
Communication Port	8158 ✓
Server Port	8658 ✓

2 Add the device to the FaceKiosk Module of the software.

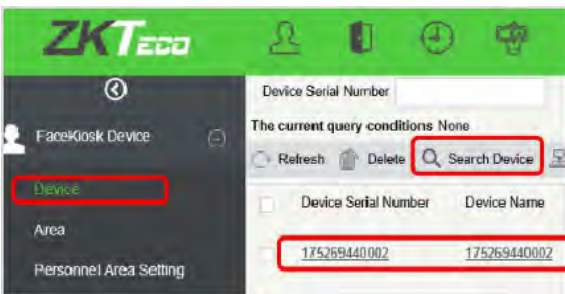

3 Set the device as an Entry device. Click Visitor Module > Basic Management > Entry Place > New.

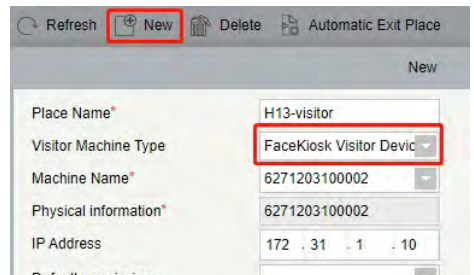

- 4 Add the sender's mailbox to the software. The system will send an Email through the sender's mailbox. Click Software System > Basic Management > E-mail Management.

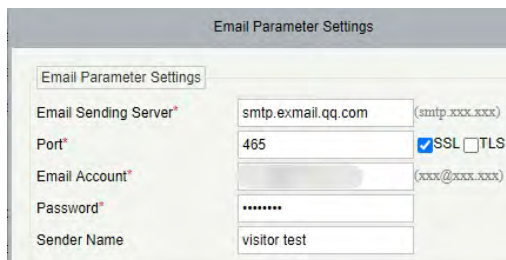

The screenshot shows the 'Email Parameter Settings' form with the following fields:

- Email Sending Server*: smtp.exmail.qq.com (smtp.xxx.xxx)
- Port*: 465 SSL TLS
- Email Account*: [Redacted] (xxx@xxx.xxx)
- Password*: [Redacted]
- Sender Name: visitor test

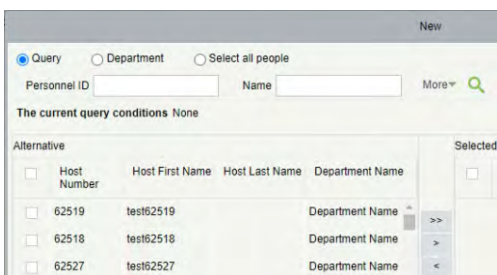

The screenshot shows a query interface with the following table:

Alternative	Host Number	Host First Name	Host Last Name	Department Name	Selected
<input type="checkbox"/>	62519	test62519		Department Name	<input type="checkbox"/>
<input type="checkbox"/>	62518	test62518		Department Name	<input type="checkbox"/>
<input type="checkbox"/>	62527	test62527		Department Name	<input type="checkbox"/>

- 5 Select an employee as the host. Click Visitor > Basic Management > Host Levels > New.

❖ Home Screen and Connectivity Status

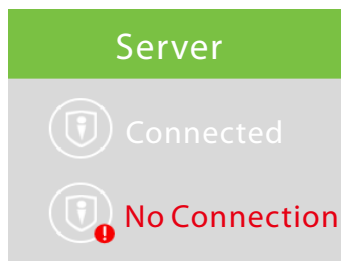
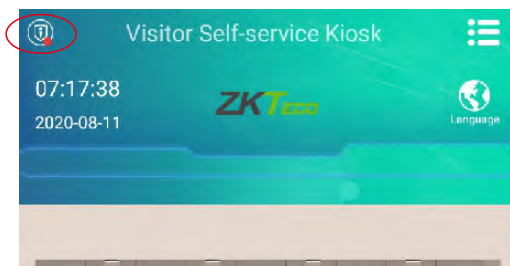

8. Visitor Management

1 Visitor Registration

Face Recognition	Can be turned on or off, and grant access through facial recognition
Temperature Detection	Can be turned on or off and this function is only available when guests register on the device
Fill Personal information	Fill the details such as Name, Phone number, E-mail address, Company name, etc.
Host and Reason	Host - Select the employee you want to visit Reason - Select the purpose of visit

2 Visitor Check-in

Tap the Check-in & Check-out button to check-in.



3 Facial Recognition

Visitors can enter the premises through facial recognition.



4 Visitor Check-out

Tap the Check-in & Check-out button to check out.



5 Reports

Export reports with complete visitor information from the software immediately.



You're all set to use Visitor Management!

ZKTeco Industrial Park, No. 32, Industrial Road,

Tangxia Town, Dongguan, China.

Phone : +86 769 - 82109991

Fax : +86 755 - 89602394

www.zkteco.com

