

# VR10

**Vehicle Detection Radar Sensor**  
Smart anti-smash and automatic closing

The radar sensor for vehicle detection VR10 is developed to detect and identify various vehicles (motorcycles, cars, trucks), pedestrians, and small (distant) objects within a detection area from 1m to 6m around the boom barrier.

Through linkage with the main board of the barrier, VR10 can help prevent vehicles from smashing the obstacles or damaging any properties or passers-by while allowing automatic boom closing.

Compared to the loop detector, it offers flexible installation. The device is at a lower risk of damage due to high impact too.

## Features

- Support vehicle and people detection
- Flexible installation; easy debugging
- Immunity to ambient weather conditions
- Detection distance can be adjusted from 1m - 6m
- Support RS485 communication, can be upgraded and debugged online
- Straight boom (default); folding boom, fence boom, and advertising boom (optional)

## Specifications

Model	VR10
Detection Distance	1 - 6m
Working Frequency	79GHz
Working Voltage (V)	DC 10 - 16V
Working Current	0.2A
Power Consumption (W)	≤2.5
Transmitter Power Output	12.5dBm
Antenna Gain	10dBi
Interface	RS485, Relay
Product Size (mm)	107.5 * 73.2 * 18
Package Dimensions (mm)	166 * 94 * 97
Net Weight	228.4g
Working Temperature (°C)	-40°C ~ 85°C
Protection Standard	IP67

## Dimensions (mm)

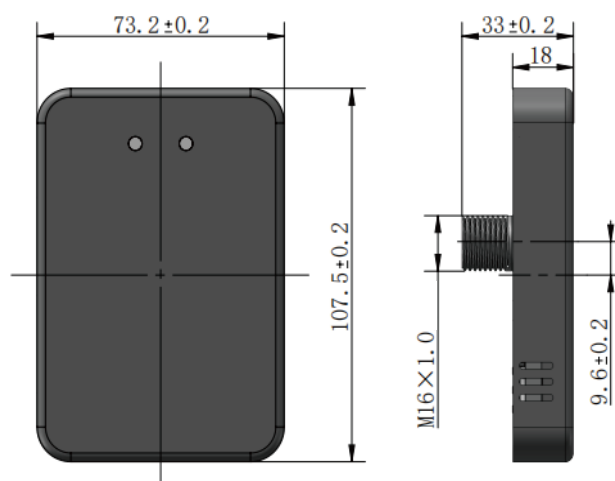

### Note:

- Currently supports straight booms, splicing booms, fence booms, but cannot be used in places with sliding doors.
- Vehicles cannot be detected by the radar sensor at the vehicle speed exceeding 15km/h.

