

Quick Start Guide

HORUS

Version: 1.1

Date: October 2019

1. Device Overview

Front

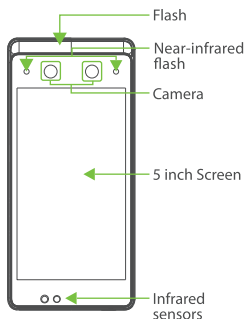

Side

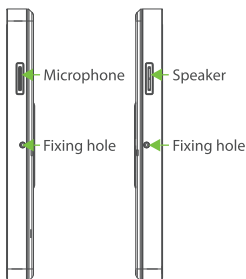

Rear

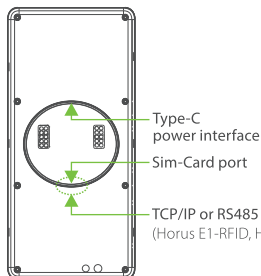

Bottom

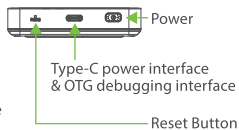

Fingerprint & RFID (Optional) ★

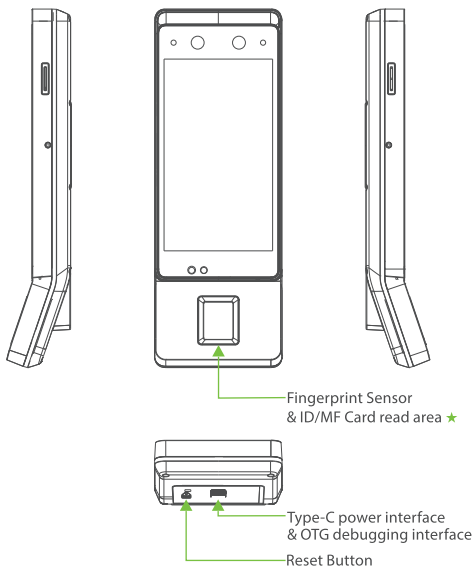

Note:

1. This port can extend to TCP/IP or RS485 communication, and it can connect to DM10 module by RS485.
2. Not all the devices have the function with★, the real product prevails.

2. Device Installation

1. Installation environment

a. Recommended location

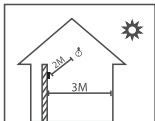

Install the device indoors at least 10 feet (3m) away from window, and 6.5 feet (2m) from light source. It is not recommended to install on the windows or in outdoor.

b. Not recommended locations

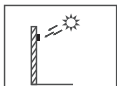

Direct Sunlight
Outdoor

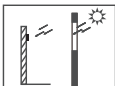

Direct Sunlight
through window

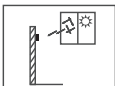

Indirect Sunlight
through window

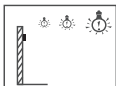

Too close to
light source

2. Installation Steps

a. Mounting on the wall

Step 1: Put the mounting template sticker onto the wall, and drill holes according to the mounting paper.

Step 2: Fix the back plate onto the wall using wall mounting screws.

Step 3: Insert the device into back plate.

Step 4: Use security screw to fasten the device to back plate.

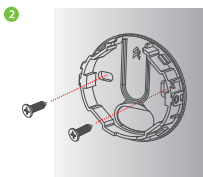

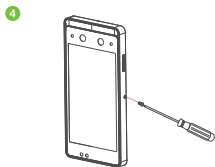
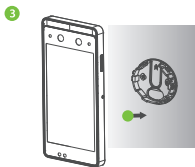

b. Mounting on the desktop holder

Step 1: Screw the back plate to the desktop holder.

Step 2: Insert the back plate into device. And use security screw to fasten the device to back plate.

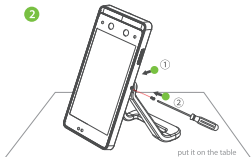
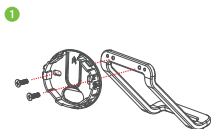

c. Mounting on the glass door

Step 1: Attach the double-sided tape to the back panel. Then attach the back plate to the glass door.

Step 2: Fix the device to the back plate. Use security screw to fasten the device to back plate.

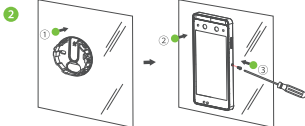

d. Mounting the optional equipment ★

Note: The installation method of optional equipment is the same and will not be repeated.

3. Power Connection



Recommended power supply:



- 12V \pm 10%, at least 2000mA.
- Please use the supplied Type-C power plug.

4. Quick Start



❖ User registration

Register on the device

Click  > Employee >  to register new employee. Enter employee name, ID, register face, fingerprint, badge number (fingerprint and ID card are optional), and password.

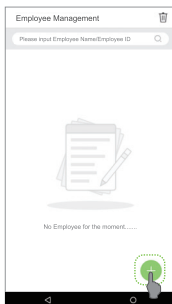

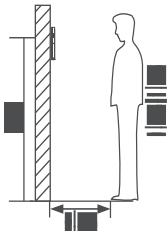

Note:

1. It's recommended to register multiple administrators.
2. It's recommended to enroll user's face in 0.5m distance, it's good for 1.4~1.8m height person.

Register on the software (BioTime 8.0)



Please set the IP address and cloud service server address on the device.

1. Click [Device] > [Device] > [Add] to add the device to the software. When the device has set the server address and port, it can be added automatically.

2. Click [Personnel] > [Employee] > [Employee] > [Add] to register users in the software.
3. Synchronize personnel on the software to devices in the corresponding area.

4. In the personnel list, select an employee (or employees) and click [More] > [Synchronize to Device] to access the confirmation interface for synchronizing.

For more details, please refer to the BioTime 8.0 User Manual.

Note: The icons  or  in the standby interface indicates that the network connection or the server is abnormal. Please check the network cable and network connection.

Register on the phone

Once BioTime 8.0 software installation, users could enroll face via browser application on their own mobile phone.

Register visible light comparison photos to verify and punch on the visible light device.

1. Choose [Personnel] > [Employee] > [Bio-photo] > [QR Code] to access the QR Code getting interface.

2. Scan the QR code via browser APP and enroll face user, user could input the `http://server_ip_address:server_port/v1Register/` on the browser APP manually as well. The following interface is entered after successful scanning:

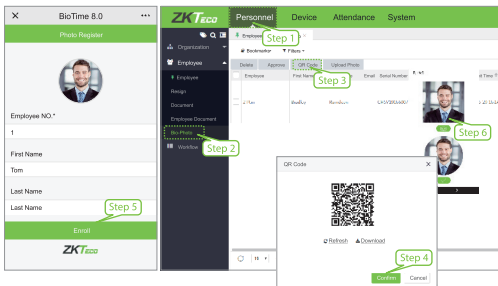

The screenshot displays the BioTime 8.0 web interface. On the left is a sidebar menu with options like 'Organization', 'Employee', 'Assign', 'Document', 'Employee Document', 'Bio Photo', and 'Workflow'. The main area shows a 'Personnel' list with columns for 'Employee', 'First Name', 'Email', and 'Serial Number'. A 'QR Code' dialog box is overlaid, showing a QR code and 'Refresh' and 'Download' buttons. A 'Confirm' button is at the bottom of the dialog. Green callouts labeled 'Step 1' through 'Step 6' indicate the sequence of actions: Step 1 points to the 'Employee' header, Step 2 to 'Bio Photo', Step 3 to 'QR Code', Step 4 to the 'Confirm' button, Step 5 to the 'Last Name' input field, and Step 6 to the 'Enroll' button.

❖ User Authentication

Terminal could detect face in 0.3m to maximum 3m distance. The device switches to face verification interface automatically once it detect bright of environment change. The verification result shows as right image.

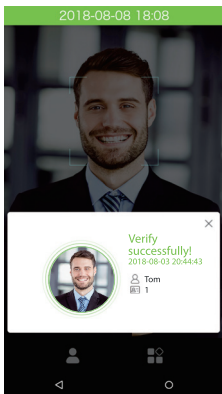

Verification is successful

❖ View records

View records on the software

Click [Attendance] > [Report] on the software to view the records.

ZKTeco Industrial Park, No.26, 188 Industrial Road,
Tangxia Town, Dongguan, China
Tel: +86 769-82109991
Fax: +86 755-89602394
www.zkteco.com

