

Quick Start Guide

Elite Access

Version: 1.1

Date: February 2020

1 Overview

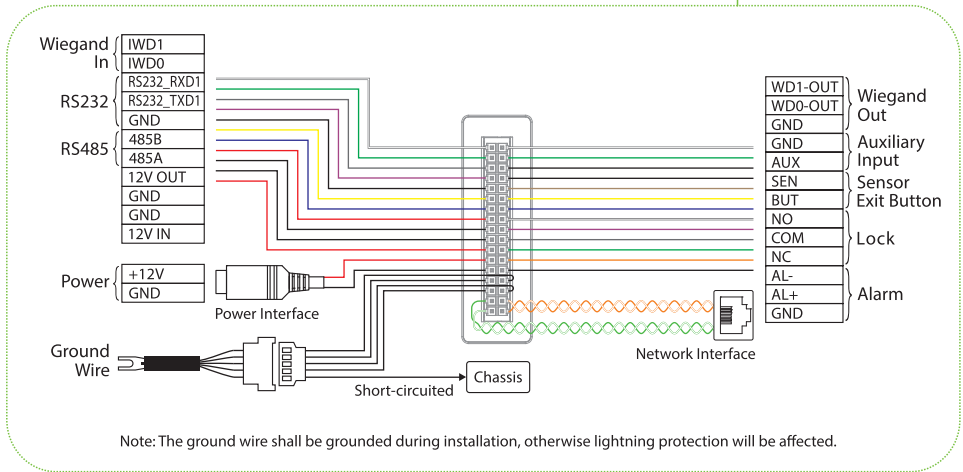
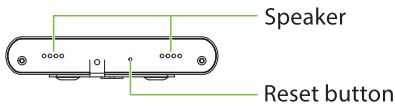
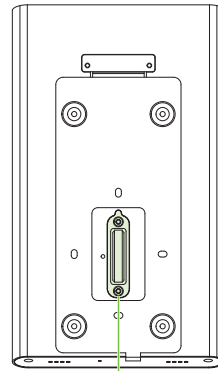
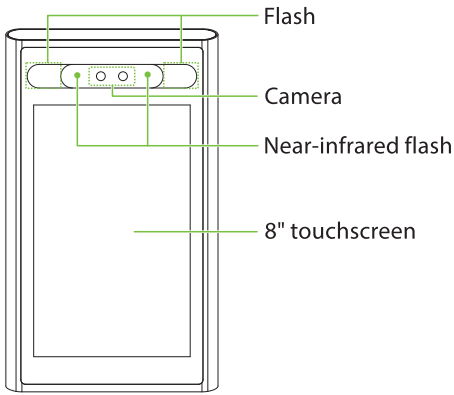

2 Device Installation

❖ Install on the wall

- ① Attach the mounting template sticker to the wall and drill holes accordingly.
- ② Fix the back plate on the wall using wall mounting screws.
- ③ Attach the device to the back plate.
- ④ Fasten the device to the back plate with a security screw.

①

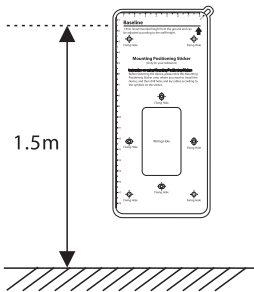

②

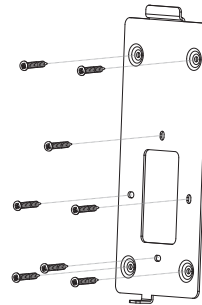

③

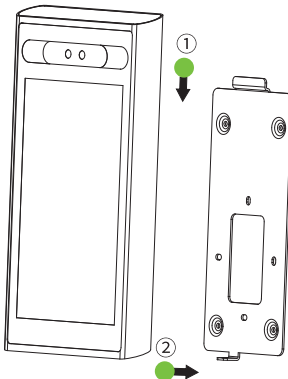

④

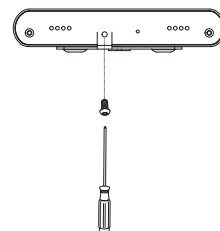

3 Standalone Installation

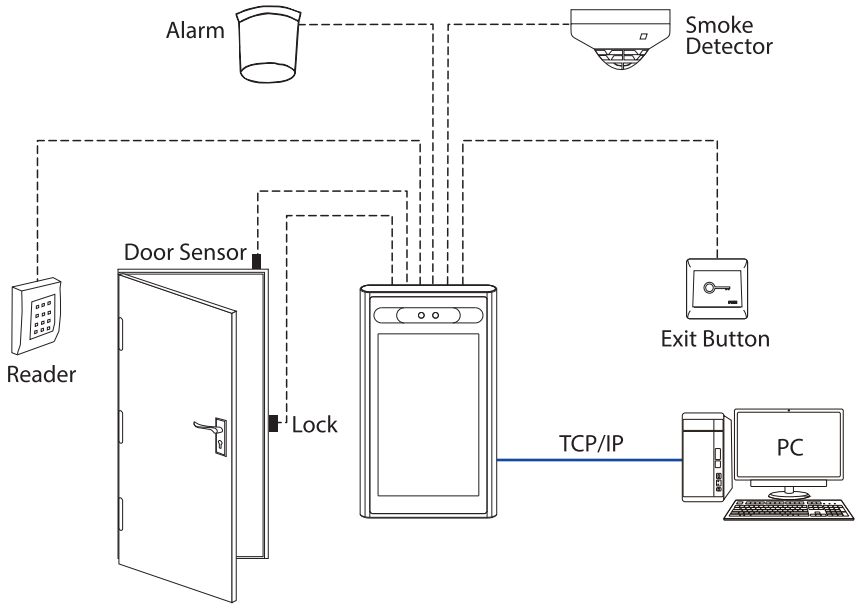

4 Door Sensor, Exit Button & Alarm Connection

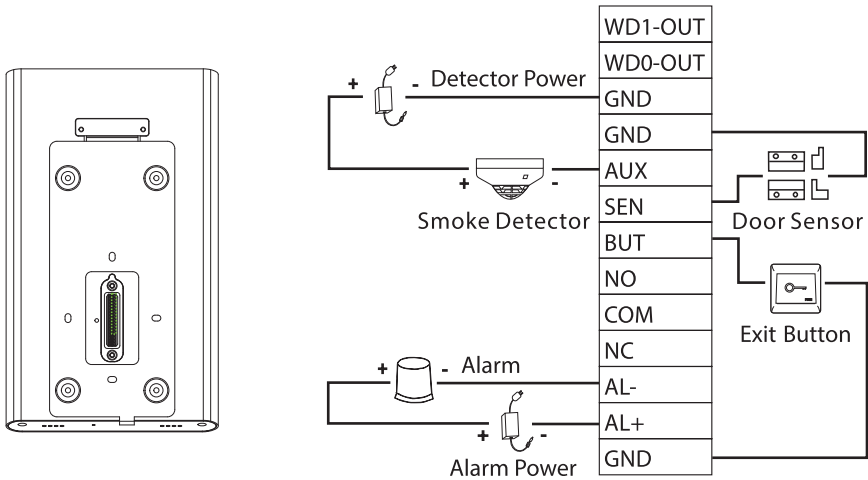

5 Lock Relay Connection

The system supports "Normally Opened Lock" ("NO Lock", normally opened when the device is power-on) and "Normally Closed Lock" (NC Lock, normally closed when the device is power-on). The NO LOCK is connected with 'NO' and 'COM' terminals, and the NC LOCK is connected with 'NC' and 'COM' terminals. Take the NC Lock as an example:

1) Device not sharing power with the lock

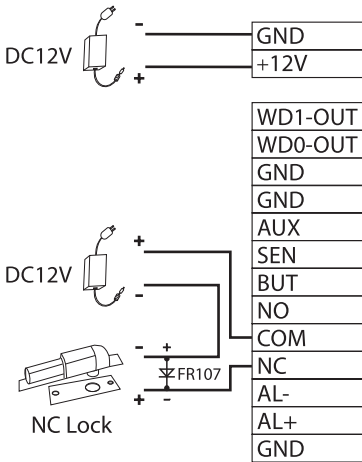

2) Device sharing power with the lock

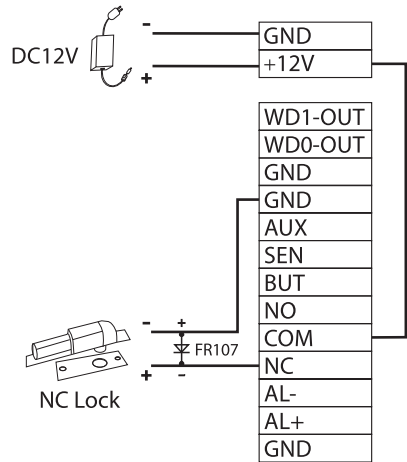

6 Wiegand Reader Connection

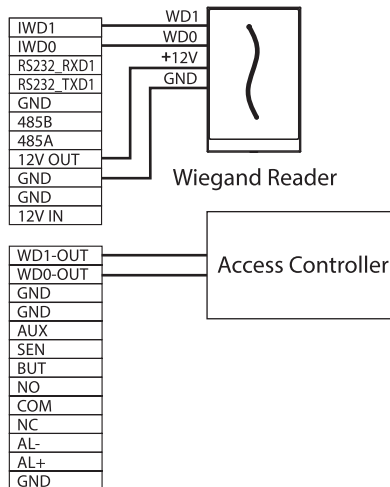
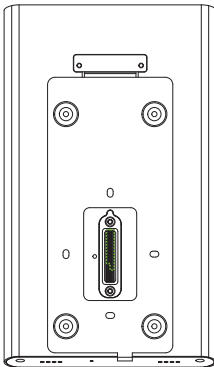

7 Barrier Connection

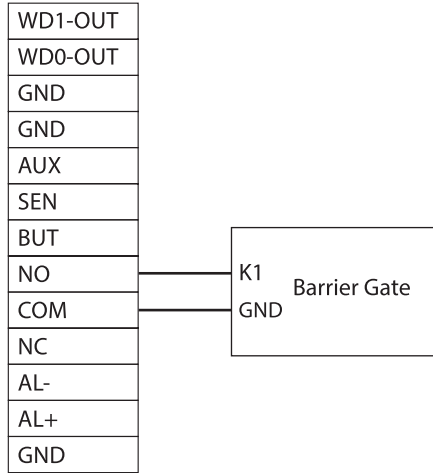
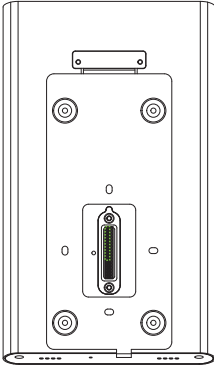

8 RS485 Connection

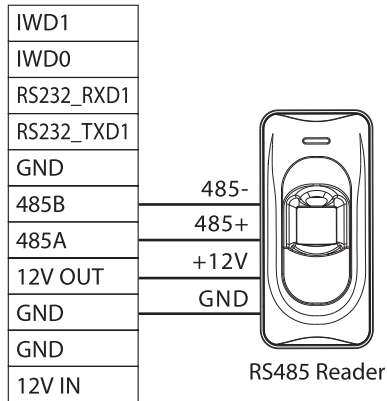
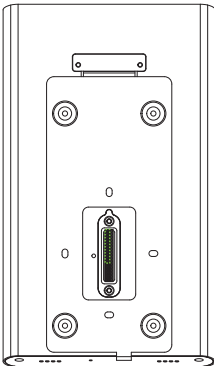

9 Power Connection

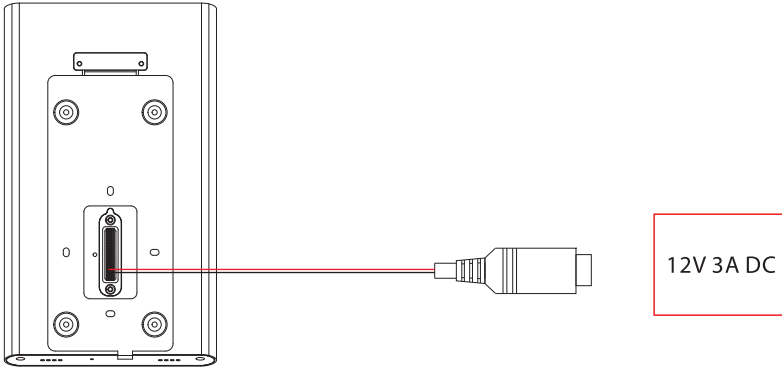

- Recommended power supply: 12V - 3A
- To share the power with other devices, use a power supply with higher current ratings.

10 Ethernet Connection

Connect the device and computer software over an Ethernet cable. An example is shown below:

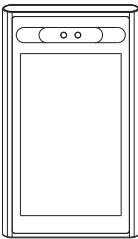

Default IP address: 192.168.1.201
Subnet mask: 255.255.255.0



IP address: 192.168.1.130
Subnet mask: 255.255.255.0

Note: In LAN, IP addresses of the server (PC) and the device must be in the same network segment when connecting to ZKBioSecurity software.

Click [Comm.] > [Ethernet] > [IP Address], input the IP address and click [OK].

11 User Registration

When there is no super administrator set in the device, click on  to enter the menu. After setting the super administrator, the system will request for the administrator's verification before entering the menu. For the security purpose, it is recommended to register for a super administrator account when you use the device for the first time.

Method1: Register on the device

Click  > [User Mgt.] > [New User] to register for new user accounts. Settings include user ID, name, user role, face, password, user photo and access control role.

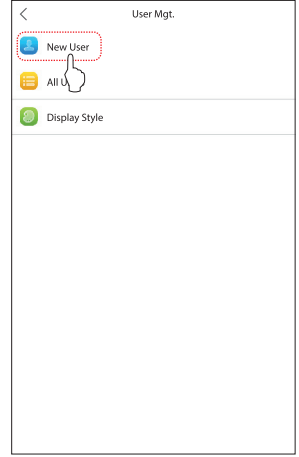
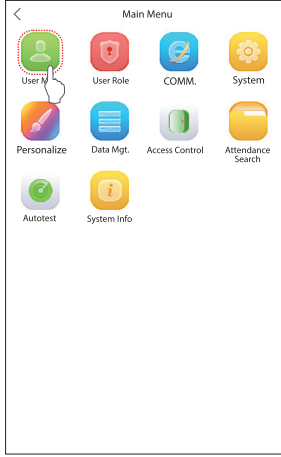
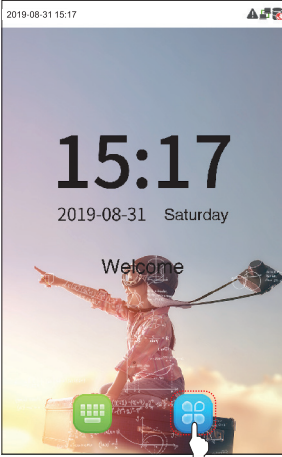

New User	
User ID	2
Name	
User Role	Normal User
Face	0
Password	
User Photo	0
Access Control Role	



Method2: Register on ZKBioSecurity software



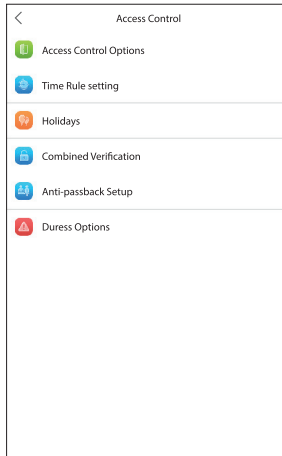
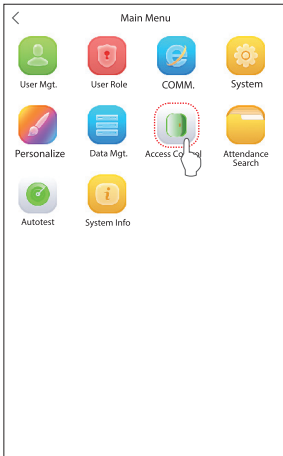

Click [Personnel] > [Person] > [New] to register users in the software. For specific operation, please refer to 'ZKBioSecurity User Manual'.

12 Access Control Settings

Click  > [Access Control] to enter the access control management interface and set relevant parameters of access control.



13 Ethernet and Cloud Server Settings

Click  > [Comm.] > [Ethernet] to set the network parameters. If the TCP/IP communication of the device is successful, the icon  will be displayed in the upper right corner of the standby interface. Click  > [Comm.] > [Cloud Server Setting] to set the server address and server port, that is, the IP address and port number of the server after the software is installed. If the device communicates with the server successfully, the icon  will be displayed in the upper right corner of the standby interface.

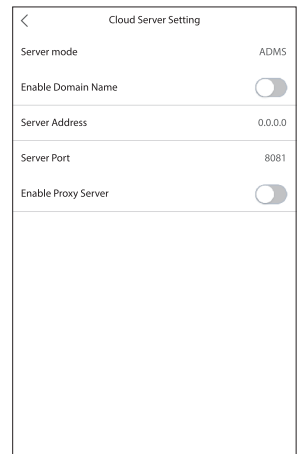
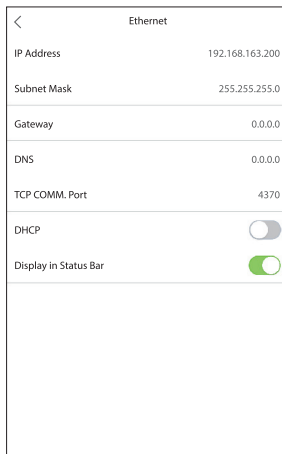
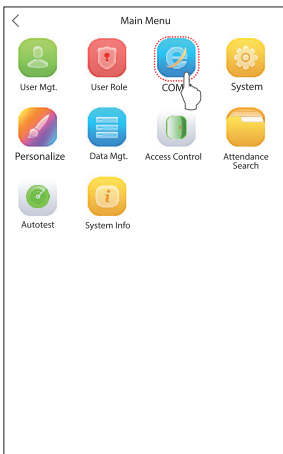

Green Label

ZK Building, Wuhe Avenue, Gangtou, Bantian, Buji Town,
Longgang District, Shenzhen, China 518129

Tel: +86 755-89602345

Fax: +86 755-89602394

www.zkteco.com

