

Elite Access

Robust Facial Recognition Terminal with Ultra-large Capacity and Anti-corrosive Coatings

Compatible with
ZKBioSecurity

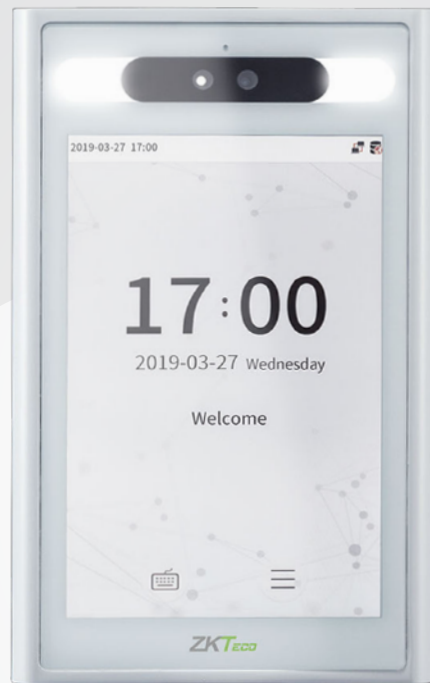

Elite Access is a new high-level facial recognition terminal with extremely powerful facial recognition capability supported with ZKTeco's customized powerful CPU and ultra-large capacity of facial templates, a maximum of 50,000 facial templates for 1:N recognition.

With its powerful core and the latest facial recognition algorithm, Elite Access rapidly recognizes a face within 0.3 second, while effectively preventing any kinds of print attack with its strong anti-spoofing algorithm.

Besides, Elite Access is equipped with a 2MP low-light WDR camera and backed by an international standard rating of IP68 and IK04 which guarantees high-quality facial recognition and outdoor durability under challenging lighting conditions (0.5lux - 50,000lux) and extreme weather from -30°C to 60°C.

Elite Access's high corrosion resistance has also been proven so the terminal is suitable for exterior and interior installation environments with different levels of salinity and humidity such as industrial and coastal areas.

Features

- Ultra-large capacity: 30,000 facial templates (standard) or 50,000 facial templates (optional) for 1:N facial authentication
- Unrivalled facial recognition speed (less than 0.3 seconds per face)
- 2MP starlight CMOS sensor camera with WDR function, which enables the terminal to recognize faces under challenging lighting environment (0.5 lux – 50,000 lux)
- Anti-spoofing algorithm against print attack (laser, color and B/W photos), videos attack, and 3D mask attack
- Smart energy-saving design; a microwave detector will wake up the terminal when it precisely detects the distance between the user and the device is 3 meters (~9.84 feet) or less
- Integrated 125 kHz prox card reader (optional Mifare)
- 8" touchscreen with 400 lux, which offers high visibility under strong and direct light
- Supplement lighting with adjustable brightness
- Multiple communication methods: TCP/IP, RS485, RS232, Wi-Fi (optional)
- IP68 dust-proof and waterproof standard and IK04 vandal-proof standard
- Wide range of working temperature (-30 ~ 60°C; -22 ~ 140°F)
- Consistent and reliable anti-corrosion protection: the plastic part of the terminal was not cracked and the metal part was not corroded after the salt fog test using 5% NaCl of around 6.5-7.2 pH at 35°C for 240 hours

Specifications (Green Label Premium Feature)

Capacity

G Faces:	30,000 (standard) 50,000 (optional)
Users:	50,000
G Transactions:	1,000,000
User Photos:	20,000
Event Photos:	10,000

Compatibility

Security Relay Box
Wiegand / RS485 / RS232 Slave Reader
With FP / RFID / Barcode (optional)
ZKBioSecurity Software

Standard Functions

Access Levels, Groups, Holidays, DST
Duress Mode, Anti-Passback
Record Query, Custom Wallpaper &
Screen Saver, Tamper Switch Alarm

Access Control Interfaces

Lock Relay Output
Alarm Output / Auxiliary Input
Exit Button / Door Sensor

Special Functions

- G IP68 & IK04
- G Corrosion Resistant (GB/T2423.17-2008)
- G 0.3s High Speed Facial Recognition
- Alive Body Detection
- HTTPS Encryption (optional)
- Event Snapshot

Communication

TCP / IP, RS485 / RS232
Wiegand Input / Output
Wi-Fi (optional)

Power

Operating Voltage 12V DC
Current Draw <2,000mA

Hardware

- G 900MHz Dual Core Customized CPU
512MB RAM / 8G Flash
- G 125KHz EM Reader / 13.56MHZ MF (optional)
- 2MP WDR Low Light Camera
- Hi-Fi Audio
- Microwave Distance Detection Sensor
- G 8" High Brightness IPS Touch LCD
- Reset Button & Tamper Switch

Additional Information

Face Algorithm:	ZKLiveFace 5.8
Working Temperature:	-30°C ~ 60°C (-22°F ~ 140°F)
Working Humidity:	≤93%
Storage Temperature:	-40°C ~ +65°C (-40°F ~ +149°F)
Storage Humidity:	≤93%
Net Weight:	1,483g
Dimensions (H*L*D):	245.6*144*25.0mm

Wiring Diagram

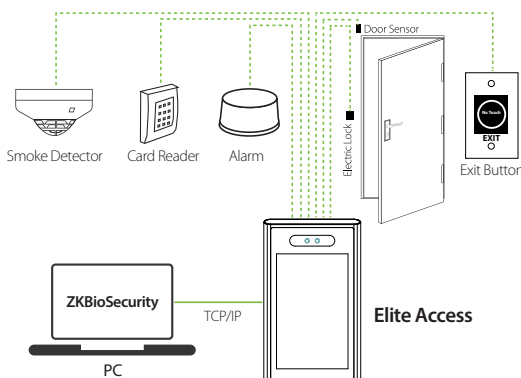

Dimensions (mm)

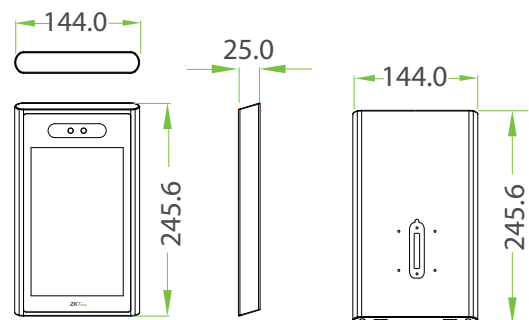

V1.0 2020.02.20