

# User Manual

## PB4000 series

---

Version: 1.0

Date: August 2019

# Contents

Chapter 1 Overview .....	1
1.1 Appearance and dimensions.....	1
1.2 Components inside the cabinet.....	1
1.3 Specification .....	2
Chapter 2 Product Installation.....	3
2.1 Installation precautions.....	3
2.2 Cable embedding .....	3
2.3 Cabinet installation .....	4
2.4 Boom installation.....	4
2.5 System diagram.....	5
2.6 Control board .....	7
Chapter 3 Connection Method.....	8
3.1 Connection with LPR camera .....	8
3.2 Connection with inBIO controller.....	9
3.3 Connection with loop detector .....	9
3.4 Connection with photoelectric beam detector.....	10
Chapter 4 Troubleshoot.....	11
Chapter 5 Device Maintenance .....	12

# Chapter 1 Overview

## 1.1 Appearance and dimensions

PB4060L/R are equipped with gray painted cabinets. The boom includes main and vice boom.

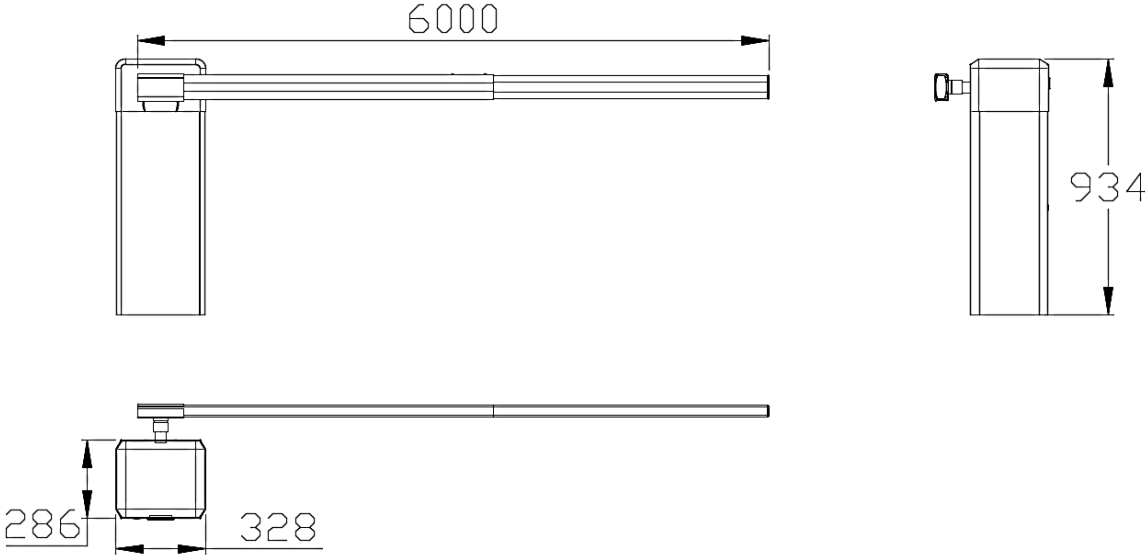

Figure 1-1 Dimension of the PB4060

## 1.2 Components inside the cabinet

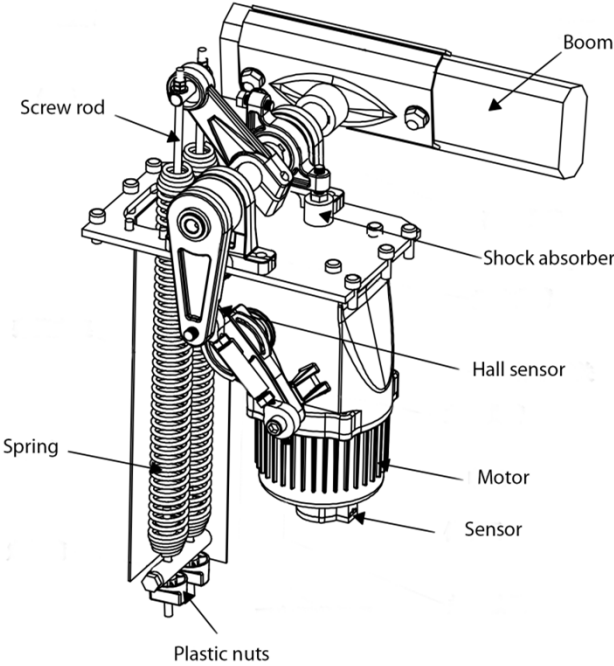

Figure 1-2 Components inside the cabinet

**Sensor:** The sensor on the bottom of motor. It is using for that if the boom falling down press any other obstacles, the boom will lifted up automatically.

**Motor:** AC power motor

**Hall sensor:** Connect to Limited switch port of control board, which limited the close/open position.

**Shock absorber:** A gel is used to absorb the pressure of close/open boom

**Spring:** Using it to keep balance with boom. For example, the boom changed short opening plastic nuts to make spring loosen a little. Otherwise the boom may can't close totally.

### 1.3 Specification

Model No.	PB4030L/R	PB4060L/R
Boom length	4m	6m
Opening / closing time	3s	6s
Supply voltage	110V AC or 220V AC	
Working current	1.3A (110V) / 2.7A (220V)	
Power consumption max.	120W	
Frequency	50-60Hz	
Cabinet material	powder coated steel	
Boom material	aluminum alloy	
Temperature range	-20°C~+60°C	
Humidity range	≤90%	
Housing dimensions (W x D x H)	328*286*934(mm)	
Packing dimensions (W x D x H)	460*420*1150(mm)	
Net weight (without boom)	60kg	
Gross weight (without boom)	70kg	

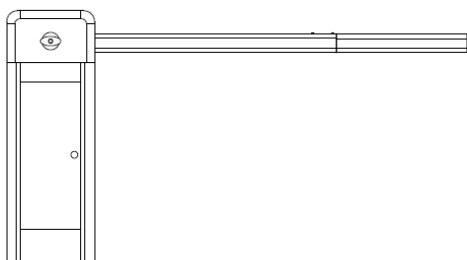

**L:** Cabinet on left side

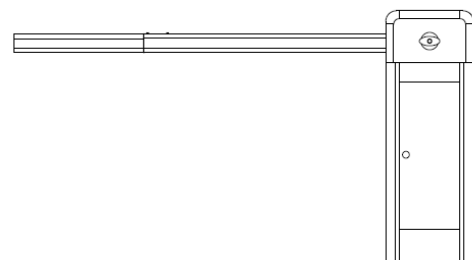

**R:** Cabinet on right side

# Chapter 2 Product Installation

## 2.1 Installation precautions

- 1) Install the parking barrier on a level ground. If the ground is not solid and level, a cement base is needed before installation.
- 2) The boom can be cut, but cannot be increased. After cutting the boom length, the spring balance needs to be set again to achieve new balance. Two plastic nuts lie in the bottom of the spring is designed for adjusting new balance.
- 3) Do not change the wire connection inside when power on.
- 4) The GND should be connected to the cabinet for secure protection.

## 2.2 Cable embedding

- 1) Prepare  $\phi 25$  protective sleeve and cable in advance.
- 2) Route cables to be connected through protective sleeves.
- 3) Use a tool to open a cable tray on the ground, see Figure 2-1.

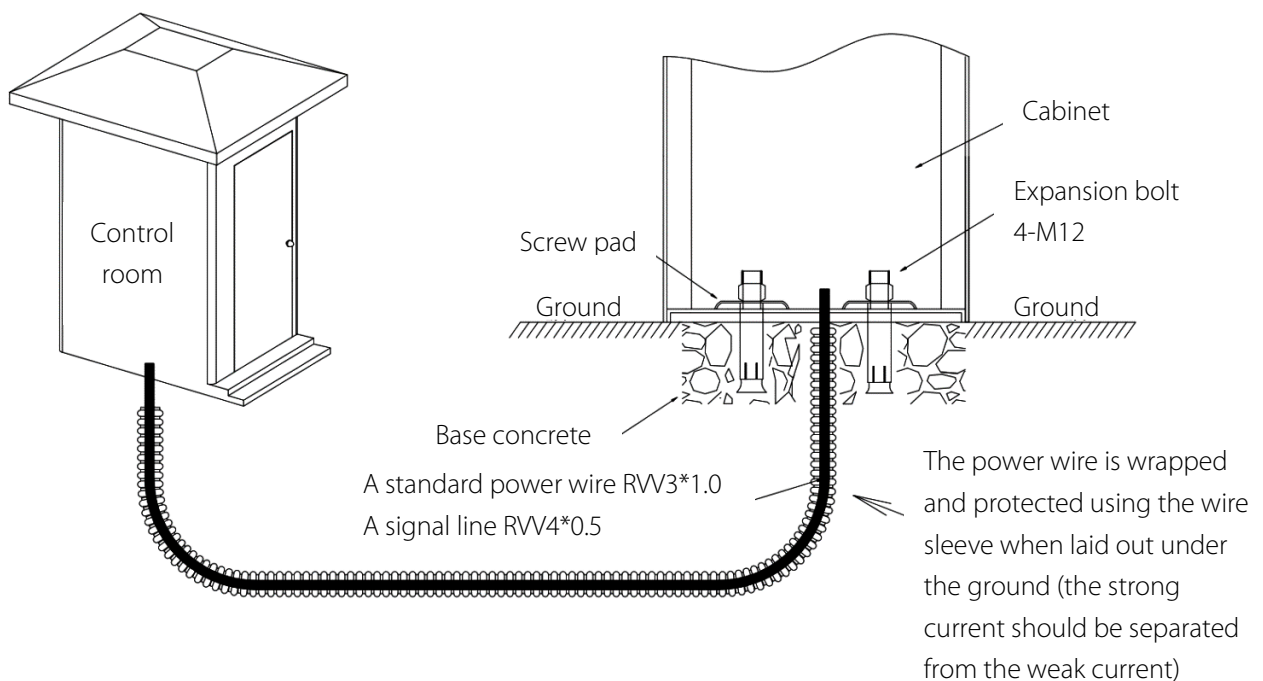

Figure 2-1 Cable embedding

## 2.3 Cabinet installation

### Installation Procedure

- 1) Use screw pad to mark the installation position of the cabinet.
- 2) Drive four expansion bolts into the bolt holes, as shown in Figure 2-2.
- 3) Install screw pads and use a wrench to tighten nuts, as shown in Figure 2-3.

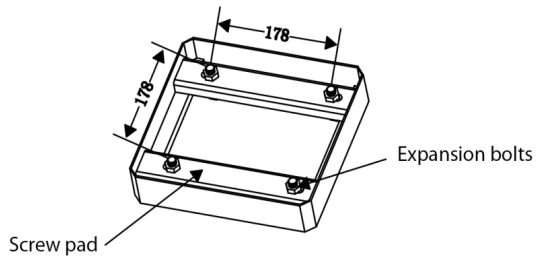

Figure 2-2

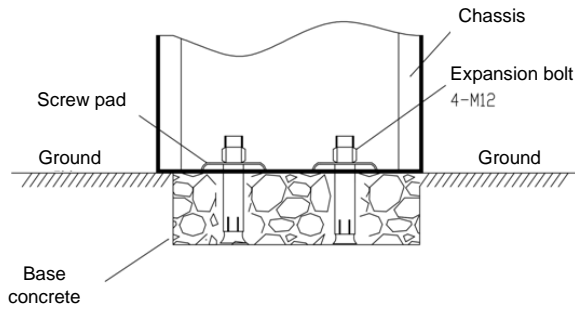

Figure 2-3

## 2.4 Boom installation

### Boom Installation Procedure

- 1) Pull the vice boom out from the main boom, then fastened by 2 screws, as shown in Figure 2-4A.
- 2) Installing the boom to the chassis, as shown in Figure 2-4B.

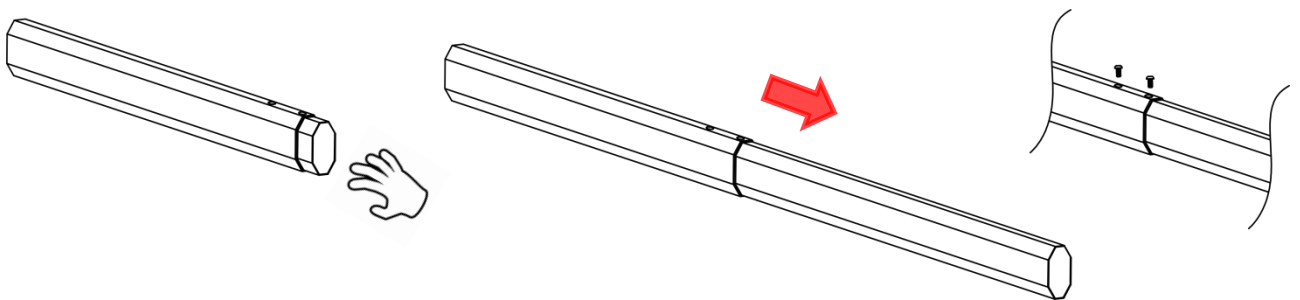

Figure 2-4A Connect the main boom with vice together by 2 screws

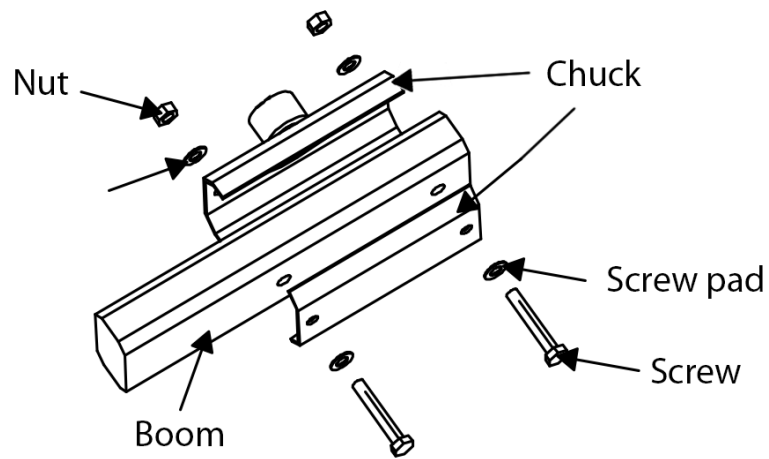

Figure 2-4B Installing the Boom to the Chassis

## 2.5 System diagram

Installation Diagram for the Parking barrier and Wall.

The distance between the cabinet and the wall should be greater than or equal to 100 mm.

The distance between the boom and the wall should be greater than or equal to 100 mm.

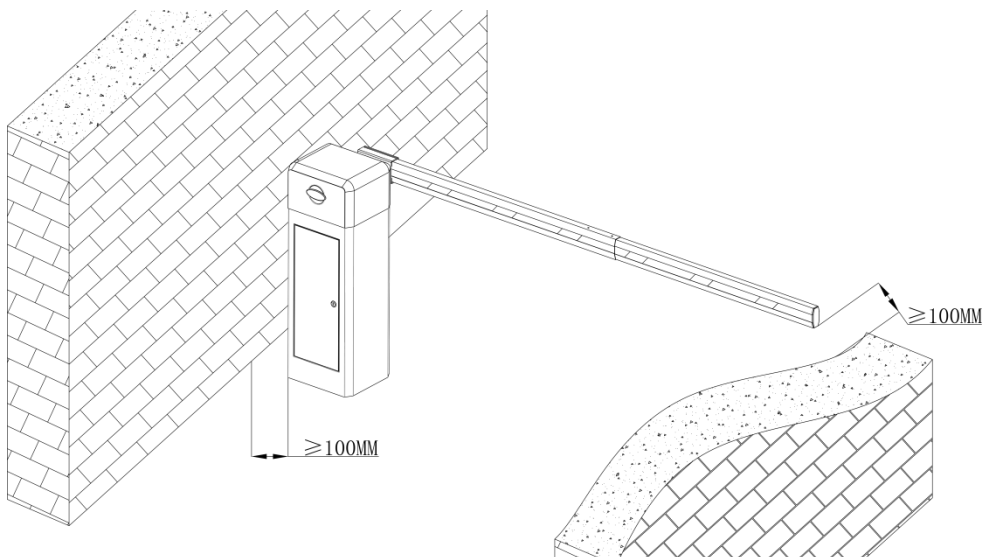

**System diagram**

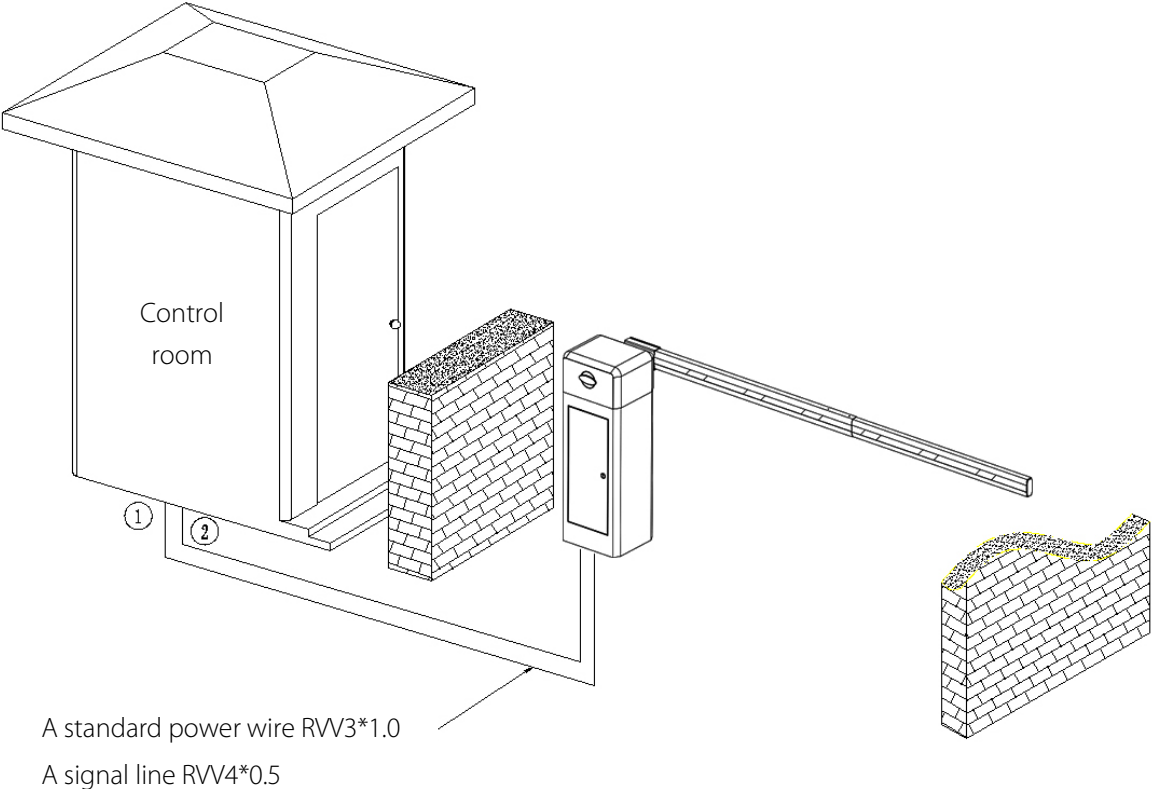



## 2.6 Control board

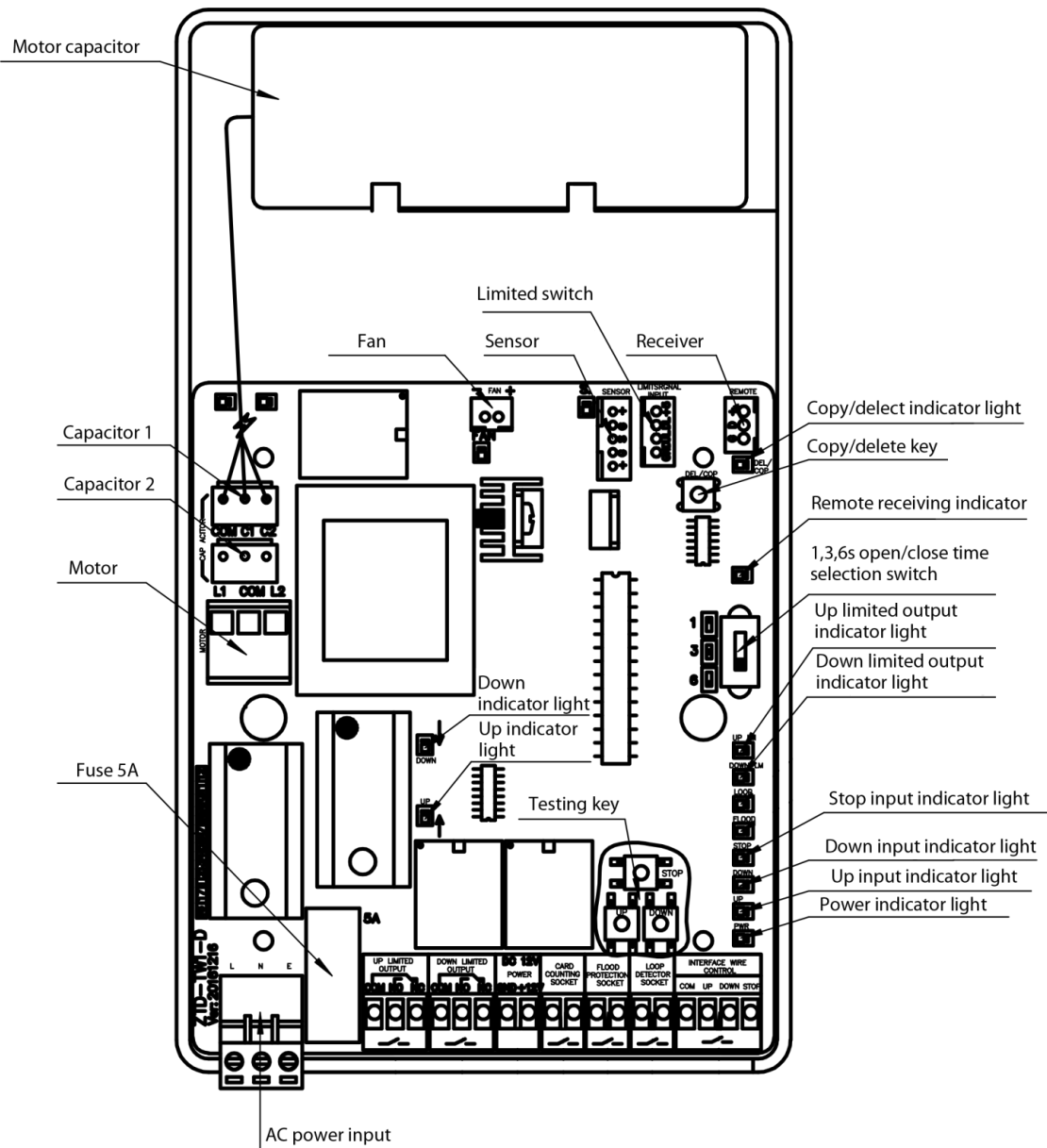

**Copy/delete key:** (Copy) press the key, and then press any other key of remote controller until the Copy/delete indicator light blinking.

(Delete) press the key until the Copy/delete indicator light blinking, then press the Stop of testing key.

**1s,3s,6s open/close time selection switch:** According to the default choice of the device model, it can't be changed at will. PB4030L/R choose 3s and PB4060L/R choose 6s.

**AC power input:** Connection with 110/220V power according to type of your purchasing. (**Note:** Do not take electricity from the control board excessively.)

# Chapter 3 Connection Method

## 3.1 Connection with LPR camera

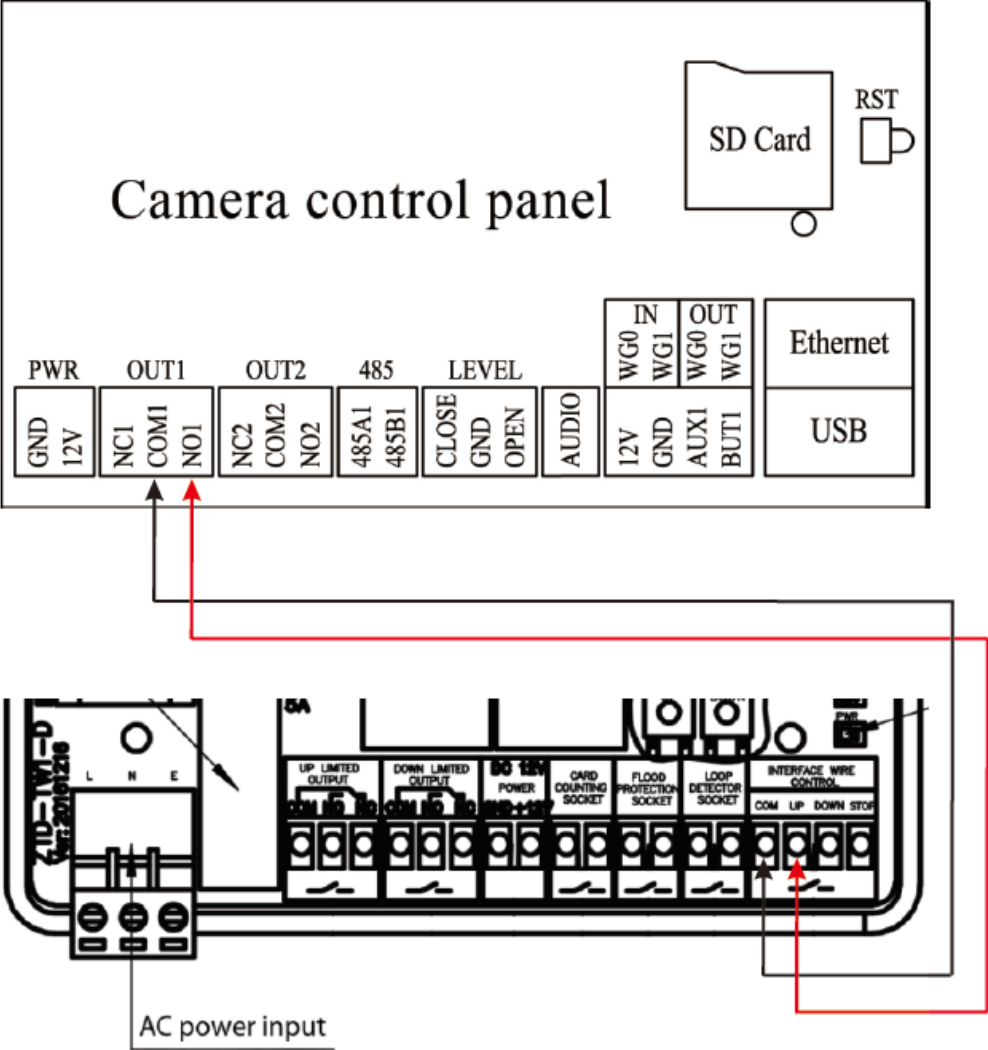

### 3.2 Connection with inBIO controller

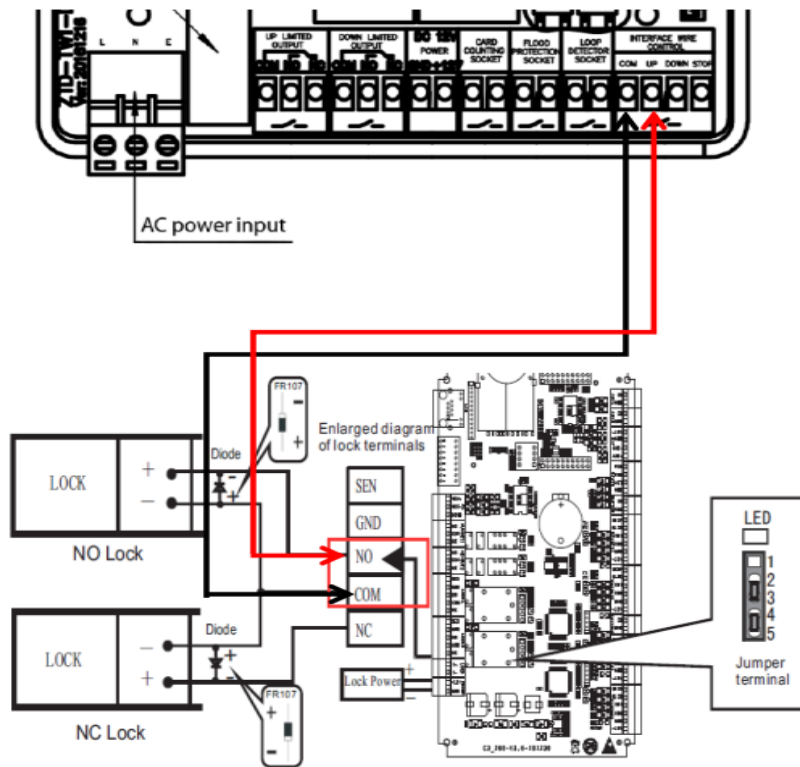

### 3.3 Connection with loop detector

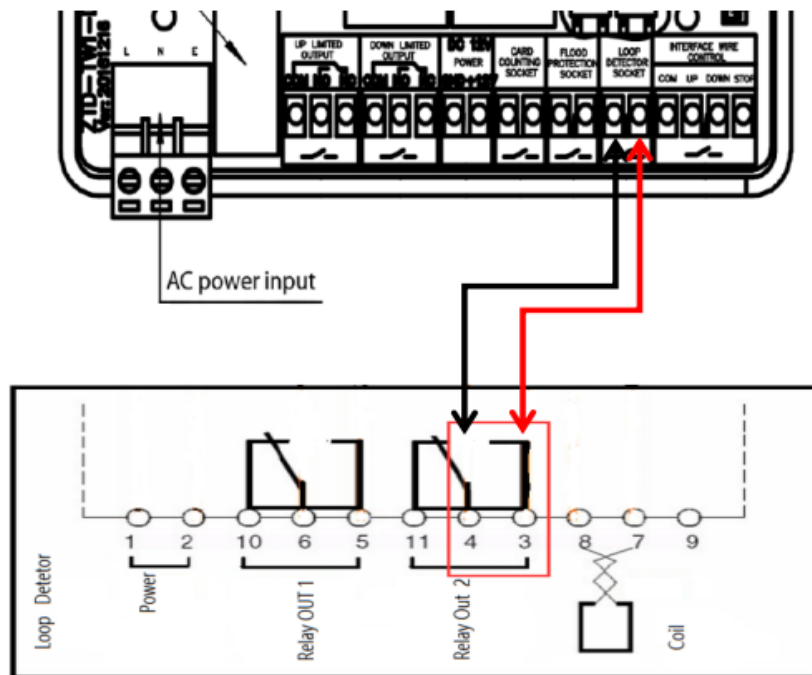

### 3.4 Connection with photoelectric beam detector

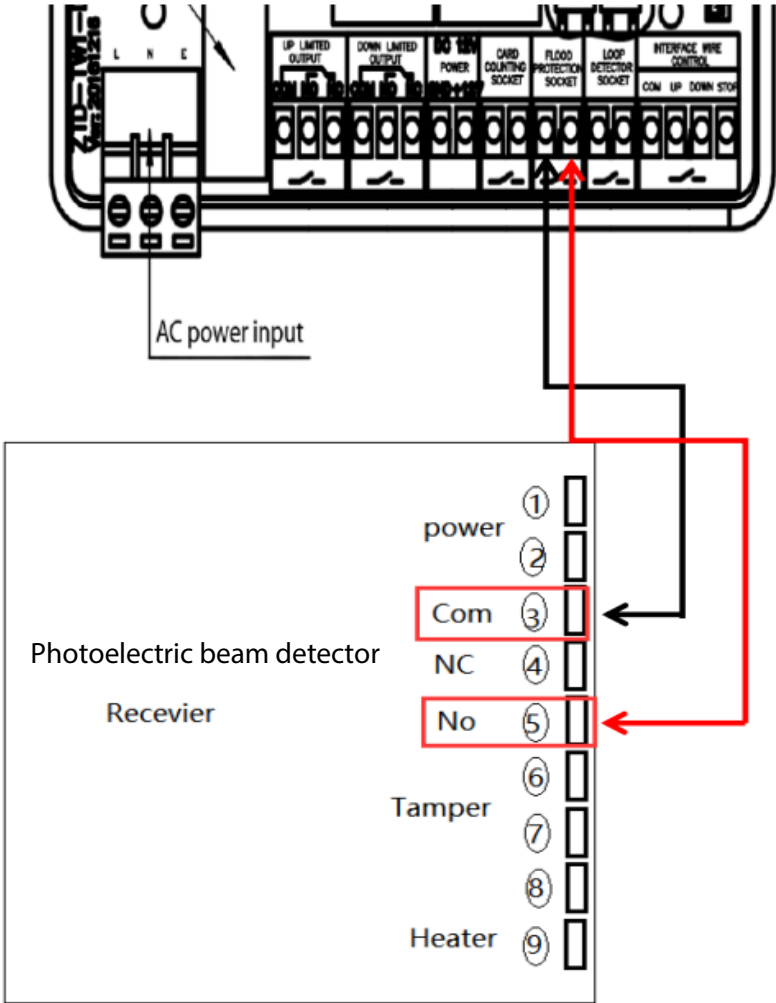

## Chapter 4 Troubleshoot

NO.	Failure description	Analysis and solution
1	Controller board's indicator light show normally, but motor does not work.	<p>A. Check whether the motor capacitor did connect correctly.</p> <p>B. Check whether the sensor did connect correctly.</p>
2	Boom has shock when the finally moment of boom close/open.	<p>A. Check whether the shock absorber gel was damaged, if yes please replace a new one</p> <p>B. Check whether the spring was fatigue deformation, if yes please adjust or replace it.</p>
3	Boom barrier can't open/close totally.	<p>A. After changed shorter boom, should have adjusted spring to keep balance,</p> <p>B. The plug of sensor did not connect correctly.</p> <p>C. Power the machine only when the boom is installed.</p> <p>D. Check if the selection switch corresponds to the model.</p>
4	The distance of remote controller decrease.	The battery of remote controller no power, change a new battery.

## Chapter 5 Device Maintenance

- 1) Maintain the boom. Fix the reflective sticker.
- 2) Tighten terminals connector of the device.
- 3) Clear dust on components inside the cabinet.
- 4) Check if the spring is loose or cracked.
- 5) Check the boom for breakage.
- 6) Check whether the terminals are loose and whether the wires fall off.

Note that technicians should maintain the parking barrier system once a month.

ZK Building, Wuhe Road, Gangtou, Bantian, Buji Town,  
Longgang District, Shenzhen China 518129

Tel: +86 755-89602345

Fax: +86 755-89602394

[www.zkteco.com](http://www.zkteco.com)

