

Easy Keypad (Outdoor)

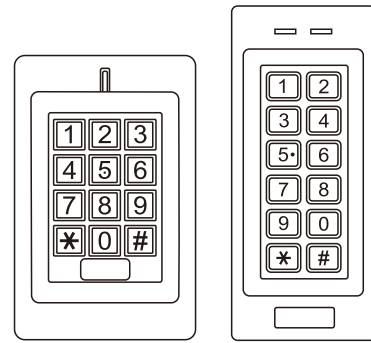

User Manual

INTRODUCTION

The device is a standalone easy keypad with built-in Mifare reader, meets the standard of ISO 14443-A and the card reading frequency is 13.56MHz. It provides secure access for up to 1000 users with 3 ways (PIN/Card/Card + PIN) to unlock the door.

The keypad built with 1 relay, the relay can operate in Pulse Mode (suitable for access control) or Latch Mode (suitable for arming/disarming alarms, switching lights, machines....etc).

The device is an ideal keypad for outdoor and harsh environments, as it is designed with anti-vandal metal housing, and the electronics are fully potted, which make this device waterproof, conform to IP66.

Features

- Vandal resistant enclosure
- Waterproof, conforms to IP66
- Backlit keypad
- One programmable relay operation
- Pulse mode, Latch mode
- 1000 users(Card/PIN/Card+PIN)
- Read 13.56MHz Mifare card (ISO14443 Type A)
- Tri-colour LED status display
- Built-in light dependent resistor (LDR) for anti-tamper
- Low temperature resistance(-40°C)

Specifications

User Capacity Card PIN	1000 13.56MHz Mifare card 4-6 digits
Operating Voltage Idle Current Working Current	9~18V DC ≤50mA ≤80mA
Proximity Card Reader Radio Technology Read Range	Mifare card (ISO14443 Type A) 13.56MHz Proximity Card/Tag ≥3CM
Wiring Connections	Relay Output, Exit Button
Relay Adjustable Relay Output Time Lock Output Load	One (NO, NC, Common) 0-99 Seconds (5 seconds default) 3 Amp Maximum
Environment Operating Temperature Operating Humidity	Meets IP66 -40°C~60°C, -40°F~140°F 10%-90% Non-condensing

Physical Surface Finish Dimensions Unit Weight Shipping Weight	Zinc-Alloy Enclosure Powder Coat L120 X W76 X H25 (mm) (Wide) L130 X W56 X H23 (mm) (Narrow) 470g(Wide)/490g(Narrow) 550g(Wide)/550g(Narrow)
---	--

Carton Inventory

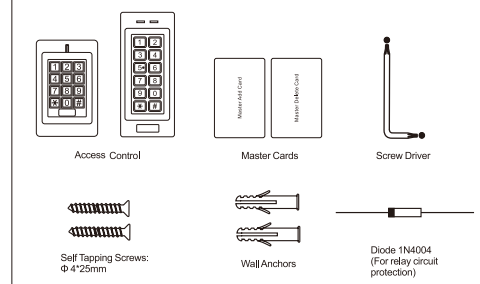

INSTALLATION

- > Remove the back cover from the unit
- > Drill 2 holes(A,C) on the wall for the screws and one hole for the cable
- > Knock the supplied rubber bungs to the screw holes(A,C)
- > Fix the back cover firmly on the wall with 4 flat head screws
- > Thread the cable through the cable hole(B)
- > Attach the unit to the back cover.

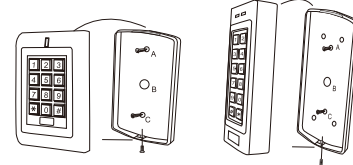

Wiring

Wire Colour	Function	Notes
Yellow	OPEN	Request to Exit input(REX)
Red	Power +	9~18 Vots DC Regulated Power Input
Black	GND	Ground
White	NO	Normally Open Relay Output
Brown	COM	Common Connection for Relay Output
Green	NC	Normally Closed Relay Output

Connection Diagram

Common Power Supply:

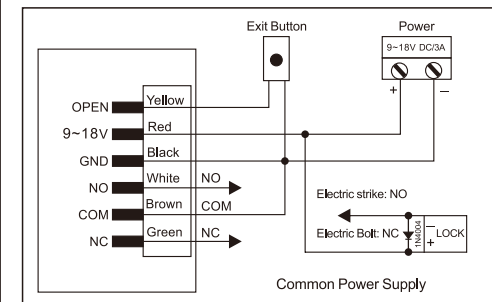

Attention: Install a 1N4004 or equivalent diode is needed when use a common power supply, or the keypad might be damaged. (1N4004 is included in the packing)

Access Control Power Supply:

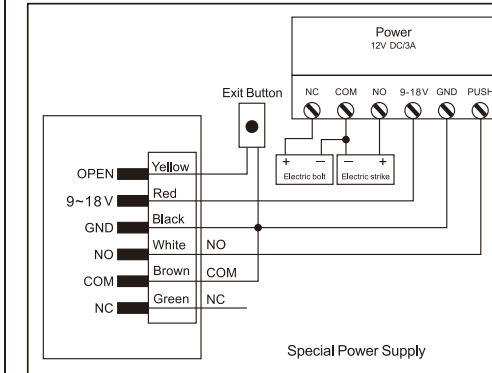

PROGRAMMING

Programming will vary depending on access configuration. Follow the instructions according to your access configuration.

Programming 1 ----- Configure the device

Change the configure settings according to your application (optional). Multiple configuration settings can be changed at one time: enter program mode, change desired settings, then exit program mode.

Set Master Code

The 4-6 digit Master Code is used to prevent unauthorized access to the system. To interface with the device, the manager will need a Master Code (factory default code: 123456). We highly recommend immediate update and record of your Master Code.

Simplified Instruction

Function Description	Operation
Enter the Programming Mode	* (Master Code) # (123456 is the default factory master code)
Change the Master Code	0 (New Master Code) # (Repeat New Master Code) # (code: 4-6 digits)
Add Card User	1 (Read Card) #
Add PIN User	1 (User ID) # (PIN) # The ID number is any number between 1 ~ 1000. The PIN is any 4-6 digits between 0000 ~ 999999
Delete User	2 (Read Card) # 2 (User ID) #
Exit from the programming mode	*
How to be granted access	
Card User	Read Card
PIN User	Enter (PIN) #

Programming Step	Keystroke Combination
1. Enter Program Mode	* (Master Code) #
2. Update Master Code	0 (New Master Code) # (Repeat New Master Code) #
3. Exit Program Mode	*

Set Access Configuration

There are 3 types of access configurations for the device
> **Card or PIN (Default):** The User must present a valid Card to the device or enter their PIN code followed by the # key, in order to be granted access.
> **Card Only:** The User must present a valid Card to the device in order to be granted access.
> **Card + PIN:** The User must first present a valid Card to the device and then enter their PIN code followed by the # key, in order to be granted access.

Programming Step	Keystroke Combination
1. Enter Program Mode	* (Master Code) #
2. Card only OR 2. Card + PIN OR 2. Card or PIN	3 0 # 3 1 # 3 2 #
3. Exit Program Mode	*

Set Relay Configuration

The relay configuration sets the behaviour of the output relay on activation.

Programming Step	Keystroke Combination
1. Enter Program Mode	* (Master Code) #
2. Pulse Mode OR 2. Latch Mode	4 (1-99) # The relay time is 1-99 seconds. (1 is 50mS.) Default is 5 seconds.
3. Exit	*

Set Strike-out Alarm

The strike-out alarm will engage after 10 failed card/PIN attempts. Default is OFF. The strike-out alarm can be set to deny access for 10 minutes after engaging or it can be set to disengage only after entering a valid card/PIN or Master code.

Programming Step	Keystroke Combination
1. Enter Program Mode	* (Master Code) #
2. Strike-Out OFF OR 2. Strike-Out ON OR 2. Strike-Out ON	7 0 # (factory default) 7 1 # Access will be denied for 10 minutes 7 2 # The buzzer alarms
Set alarm time	5 (0 ~ 30) # Factory default is 1 minute
3. Exit	*

Programming 2 ----- Program Cards and PINs

Programming will vary depending on the access configuration. Follow the instructions according to your access configuration.

GENERAL PROGRAMMING INFORMATION

> **User ID Number:** Assign a user ID number to the access code in order to keep track of the users of access cards or PINs. The user ID number can be any number from 1~1000. IMPORTANT: User IDs do not have to be proceeded with any leading zeros. Recording of User ID is critical. Modifications to user data require either the card or the User ID be available.
> **Proximity Card:** 13.56MHz Mifare Card (ISO14443 Type A)
> **Keypad PIN:** The PIN can be any 4-6 digits between 0000~999999 (except 1234 which is reserved for factory testing).

ACCESS CONFIGURATION: CARD OR PIN & CARD ONLY

Programming Step	Keystroke Combination
1. Enter Program Mode	* (Master Code) #

2. Add Card: Using Auto ID (Allows device to assign Card to next available User ID number)	1 (Read Card) # Cards can be added continuously.
OR 2. Add Card: Select Specific ID (Allows manager to define a specific User ID to associate the card to)	1 (User ID) # (Read Card) # The user ID is any number from 1~1000.
3. Exit Program Mode	*

Delete User Cards

Programming Step	Keystroke Combination
1. Enter Program Mode	* (Master Code) #
2. Delete Card: By card OR 2. Delete Card: Select Specific ID	2 (Read Card) # Cards can be deleted continuously. 2 (User ID) # The user ID is any number from 1~1000.
3. Exit	*

Add or Delete a PIN

Programming Step	Keystroke Combination
1. Enter Program Mode	* (Master Code) #
2. Add a PIN Assigns PIN to user ID number OR 2. Delete a PIN Deletes the User ID number and associated PIN	1 (User ID) # (PIN) # PINs can be added continuously. 2 (User ID) # PINs can be deleted continuously.
3. Exit	*

Change a PIN

This operation is executed from outside of Program Mode.

Programming Step	Keystroke Combination
1. Change a PIN	* (User ID) # (Old PIN) # (New PIN) # (New PIN) #

ACCESS CONFIGURATION: CARD+PIN

Add a Card+ PIN User

Programming Step	Keystroke Combination
1. Enter Program Mode	* (Master Code) #
2. Add a User Card by ID number	1 (User ID) # (Read Card) #
3. Exit Program Mode	*
4. Add PIN	* (Read Card) (1234#) (New PIN) # (New PIN) # This operation is executed from outside of Program Mode

Change PIN

Allows card user to update the PIN for their Card + PIN User ID. This operation is executed from outside of Program Mode.

Programming Step	Keystroke Combination
1. Change PIN using a Card OR 1. Change PIN using User ID	* (Read Card) (Old PIN) # (New PIN) # (New PIN) # * (User ID) # (Old PIN) # (New PIN) # (New PIN) #

Delete Card by User ID

Deleting by ID number will clear cards and PINs

Programming Step	Keystroke Combination
1. Enter Program Mode	* (Master Code) #
2. Delete User Card by User ID	2 (User ID) #
3. Exit Program Mode	*

OTHERS

Reset to Factory Default:

This will reset the device to the factory default but all card/PIN information will still be retained.
1. Power the device off.
2. Press the exit button, hold it and power on
3. There will be two beeps, release the exit button
4. Then read any two 13.56MHz Mifare card/tag, the 1st one is Master Add Card, the 2nd one is Mater Delete Card, the LED will turn into red

The device has been reset successfully.

Erase all Users

This will delete ALL User data.
1. Enter Program Mode by press: *** (Master Code) #**.
2. Press 20000 #
3. Exit: *****
All configuration data is retained.

Reset Strike-Out Alarm

Enter Master Code or Valid Card/PIN to silence

Master Cards Usage

Using Master Card to add and delete card users	
Add Card User	1. (Read Master Add Card) 2. (Read User Card) 3. (Read Master Add Card) Repeat Step 2 for additional user cards
Delete Card User	1. (Read Master Delete Card) 2. (Read User Card) 3. (Read Master Delete Card) Repeat Step 2 for additional user cards

Sound and Light Indication

Operation Status	Red LED	Green LED	Sounds
Power on	Flashing		Short Single Beep
Stand by	Flashing		
Press Keypad	Flashing		Short Single Beep
Enter Master Code Entry Mode	ON		Short Single Beep
In program mode	ON	Single Flash	Short Single Beep
Entered Program Step Successfully	ON	Single Flash	Short Single Beep
Entered Program Step Incorrectly			Short Single Beep
Exit from the programming mode	Flashing		3 Short Beeps
Entry Granted		ON	Short Single Beep
Open lock	Green light bright		One beep
Alarm Mode Engaged	Flashing		Alarm
Alarm	Red light Shines quickly		Beeps
Pressing * Toggles Standby / Master Code Entry	ON/Flashing		Short Single Beep