

## SBT1000S Series

**SBT1000S** Single Lane Swing Barrier Turnstile

**SBT1011S** Single Lane Swing Barrier Turnstile

(w/ controller and RFID reader)

**SBT1022S** Single Lane Swing Barrier Turnstile

(w/ controller and combination fingerprint & RFID reader)

Combined with mechanical, electronic, microprocessor control hardware and RFID technology. Considering availability of different dimensions, SBT1000S swing barrier is a useful solution to provide access control for people with special needs/ disabled.

The SBT1000S is a single lane swing barrier turnstile series designed for smooth and silent operation and low power demand. It's made of stainless steel which makes SBT1000S highly durable.

SBT1000S tempered-glass barriers are normally held in a locked position that deny access to the secured side. After SBT1000S's reader (RFID /fingerprint) recognized user's valid access card or fingerprint, its barriers will swing automatically, that allow the users pass to the secured side.

During emergencies, the barriers will swing automatically that ensure user can quickly access to EXIT. If power outages, the barriers will unlocked automatically that user can push the barriers to go through the lane.

### Features

#### Reliability

- SUS304 stainless steel body provides ultra-high durability.
- High quality electrical components.
- Anti-crash function.

#### Safety Features

- Barriers unlocked automatically during power outages.
- Smooth and quiet operation and without exposed screws.
- Durable electrical components.

#### Built-in Reader Integration

- SBT1000S series already integrated with customers' preference for either card or fingerprint access control reader which greatly reduces installation time & expenses.
- SBT1000S series and associated access control readers have passed the factory test before shipment.
- ZKTeco provides the plug&play device with the lowest price in the whole industry.

# Specifications

|                            |             |   |
|----------------------------|-------------|---|
| Power requirements         |             | AC110V/220v,50/60HZ                           |
| Working temperature        |             | -28°C~60°C                                    |
| Working humidity           |             | 5%~80%  |
| Working environment        |             | Indoor/Outdoor (if sheltered)                 |
| Speed of throughput        | RFID        | Maximum 10/ minute                            |
|                            | Fingerprint | Maximum 10/ minute                            |
| Lane width(mm)             |             | 800   |
| Footprint(mm*mm)           |             | 985*200                                       |
| Dimensions(mm)             |             | L=985,W=200,H=1100                            |
| Dimension with packing(mm) |             | L=280,W=280,H=1160                            |
| Net weight(kg)             |             | 31  |
| Weight with packing(kg)    |             | 38  |
| LED indicator              |             | Y   |
| Cabinet material           |             | SUS304 Stainless Steel                        |
| Lid material               |             | SUS304 Stainless Steel                        |
| Barrier material           |             | Tempered glass (stainless speed bar optional) |
| Barrier movement           |             | Swing   |
| Emergency mode             |             | Y   |
| Security level             |             | Medium  |
| MCBF                       |             | 2 million                                     |

## Dimensions (mm)

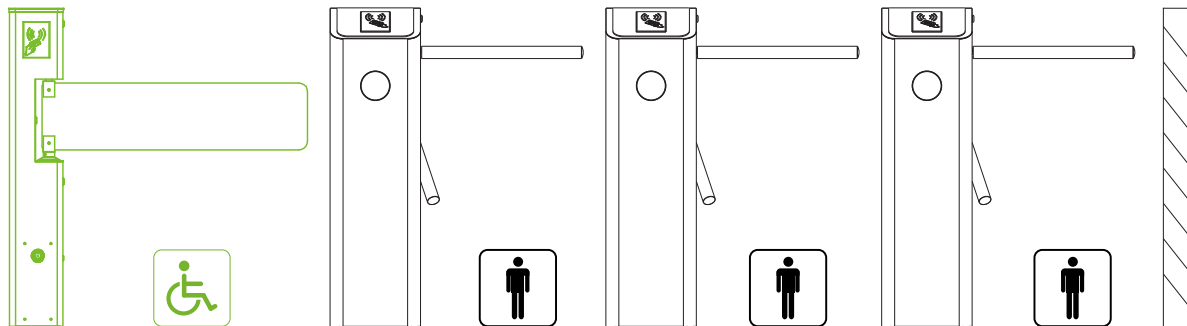
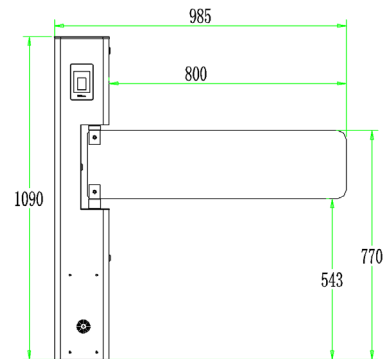
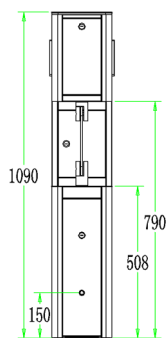

SBT1000S is usually used with other types of turnstiles together. It is suitable for trolleys, wheelchair passthrough, and is not suitable for high-traffic volume.

