

# Access Control Color Screen RFID Series Product Installation Guide

Version: 1.1 Date: Jan. 2014

**Note:** This device works standalone or networked. ZKAccess3.5 software is required for networked management.

## 1. Equipment installation

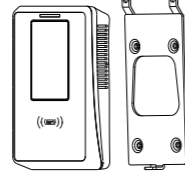
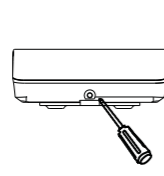
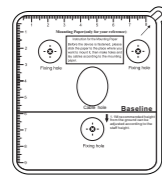

- Paste the mounting template on the wall. Drill the holes according to the marks on the template (holes for screws and wiring).
- Remove the screws on the bottom of device.
- Take away the back plate.

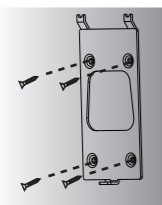

- Fix the back plate on the wall according to the mounting paper.
- Place the unit onto the mounting bracket, and tighten the screws at the bottom of the unit.

## 2. Structure and Function

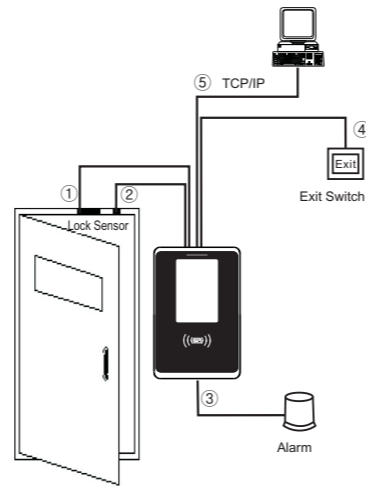

Access Control System Function

- If a registered user verified, the device will trigger the lock control relay to open the door.
- The door sensor will detect the ON-OFF state. If the door is unexpectedly opened or improperly closed, the alarm relay will be triggered.
- If the device is illegally removed, the alarm relay will be triggered.
- External exit button is supported.
- Supports TCP/IP communication to be able to connect with a PC. One PC can manage multiple devices.

## 3. Lock Connection

- The system supports NO lock and NC lock. For example the NO lock (normally open at power on) is connected with "NO" and "COM" terminals, and the NC lock is connected with "NC" and "COM" terminals.
- When the electrical lock is connected to the Access Control System, you need to connect one FR107 diode (shipped in package) in parallel with the connection to prevent self-inductance EMF feedback the system. NB: Do not reverse the polarities!

**WARNING: Do Not operate with Power connected.**

### 1) Share power with the lock:

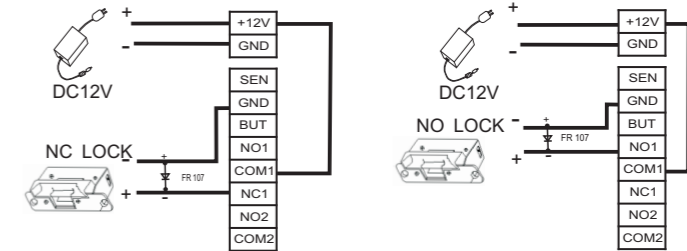

Device share power with the lock:

ULOCK=12V, I-LOCK>1A.....1); And the distance between the lock and the device is ≤10 meters.

### 2) Does not share power with the lock:

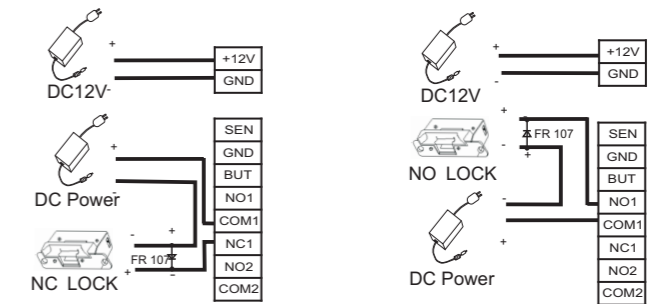

Device does not share power with the lock:

A. ULOCK=12V, I-LOCK≤1A; B. ULOCK≠12V; C. The distance between the lock and the device is >10 meters.

D. We suggest user does not share power with the lock.

1): 'I': device output current, 'ULOCK': lock voltage, 'ILOCK': lock current.

## 4. Other Connections

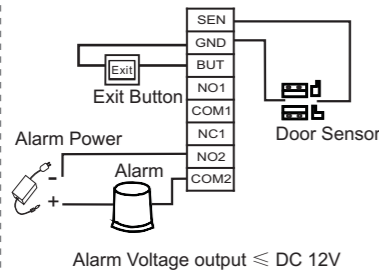

## 5. Power Connection

The device working voltage DC 12V, electric current 500mA (50mA for standby current). Positive is connected with '+12V'; negative is connect with 'GND' (do not reverse the polarities).

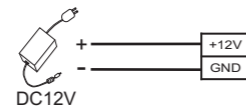

## 6. Wiegand Output

The device supports standard Wiegand 26-bit output, so you can connect it with various access control devices.

Access Control Panel

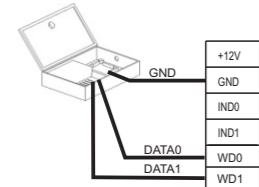

## 7. Wiegand Input

The device has a Wiegand input port, which enables the connection to a slave card reader. Devices are control devices on both sides of the door to control the access and electric lock.

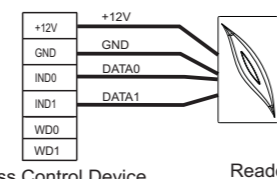

- Don't exceed 90m (meters) distance between the Device and Access Control Lock or Card Reader. (In the case of long distance installation, use the Wiegand Signal Extender, to minimise interference.)
- To keep a balanced and stable Wiegand signal, connect the device, access control lock or card reader on the same "GND" (ground) port.

## 8. Other Functions & Features

### (1) Manual Reset:

If the device does not work properly because of misoperation or other abnormality, you can use 'Reset' function to restart it.

Operation: Remove the black rubber cap, then stick the Reset button hole with a sharp tool (the tip diameter is less than 2mm).

### (2) Tamper Alarm Function:

If the device is being illegally removed, the button loses connectivity and will trigger the alarm.

Side View Back View

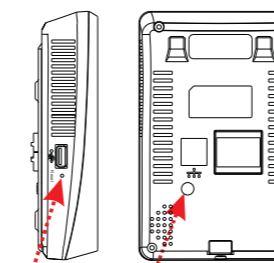

Reset Button Tamper Button

## 9. Communication

TCP/IP Mode:

Two ways for TCP/IP connection.

(A) Crossover cable: The device and PC connected directly.

(B) Straight cable: The device and PC connected to LAN/WAN through switch/Lanswitch.

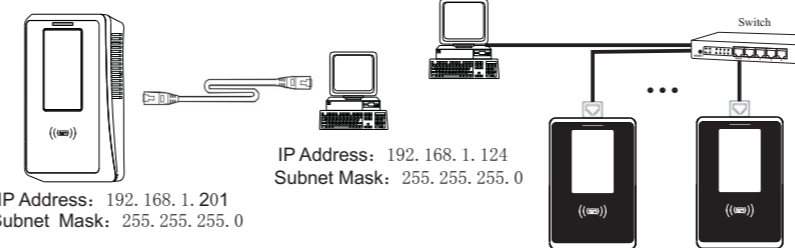

IP Address: 192.168.1.201  
Subnet Mask: 255.255.255.0

IP Address: 192.168.1.124  
Subnet Mask: 255.255.255.0

## 10. Caution

**WARNING: Do Not operate with Power connected.**

- Connect the power cable after all the wiring has been completed. If the device is working abnormally, please shut down the device, and make necessary checks. Please note that any "HOT SWOP" of wiring on the device may damage the device, and the warranty does not cover damage caused by improper operations.
- We recommend use the DC 12V/3A power supply. Please contact our technical staff for details.
- Please read the terminal and wiring description and diagrams carefully before commencing with installations. Any damage to the device caused by improper operations, will not be covered under warranty.
- Keep the exposed part of wire less than 5mm, to avoid unexpected connection.
- Please connect the 'GND' when starting installations, especially in an environment where static electricity is very high.
- Do not change the cable type in case of a long distance installations.

\* Reserves the final rights of modification and interpretation.