

ELECTRIC LOCKS

AL-130 Series Electric Strike User Manual



Welcome to use Advanced Lock products. In order to protect your rights and interests, read this User Manual carefully before use. Please contact the dealer or the manufacturer in case of query.

Applicable Range: This lock is applicable for use together with anode mechanical lock or ball lock in office buildings, wooden doors, stainless steel doors, fire doors and entrance gate of residence community.

Product Advantage: Recessed type installation and pleasant-looking appearance. The electromagnetic part adopts high-quality magnetic materials and special processing workmanship to ensure normal use and no residual magnetism even after long time operation.

Door Opening: 90° and available for load of 250kg

Electrical Property: Users can select appropriate products with different models and functions based on the following table. Customization is available according to users' requirements.

Model	Voltage (DC)	Current (mA)	Unlock Method	Customization is available for products with 6-24VDC;
AL-130NO	12V ± 15%	240	NO - unlock by connecting power	
AL-130NC	12V ± 15%	120	NC - unlock by disconnecting power	

Wiring: 1. One diode is an accessory provided in the accessory bag. The diode is used to prevent bounce-back current and voltage produced during locking or unlocking from affecting the access control mainframe. Users can connect the diode to the wiring terminal in parallel.

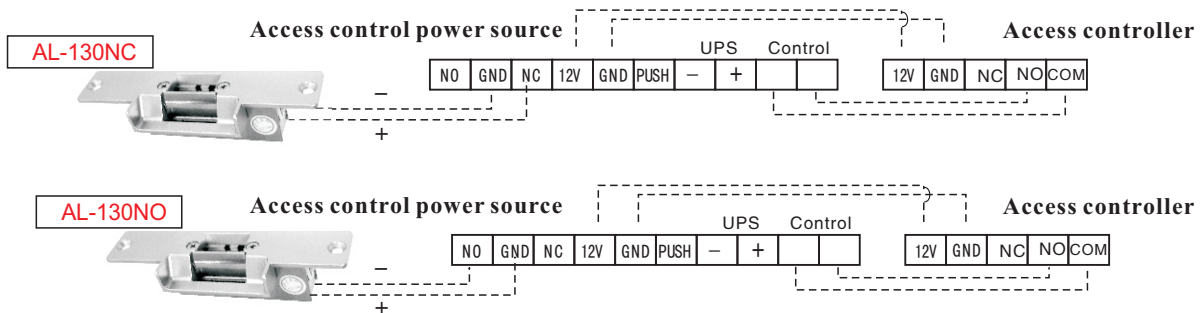

- Precautions:**
1. Read this User Manual carefully before installing the electric strike.
 2. Select qualified power source and wires to avoid insufficient locking force caused by abnormal power supply.
 3. This lock has no delay function. If delay function is necessary, it shall be used together with the controller.

AL-130 Series Electric Strike Installation Drawing

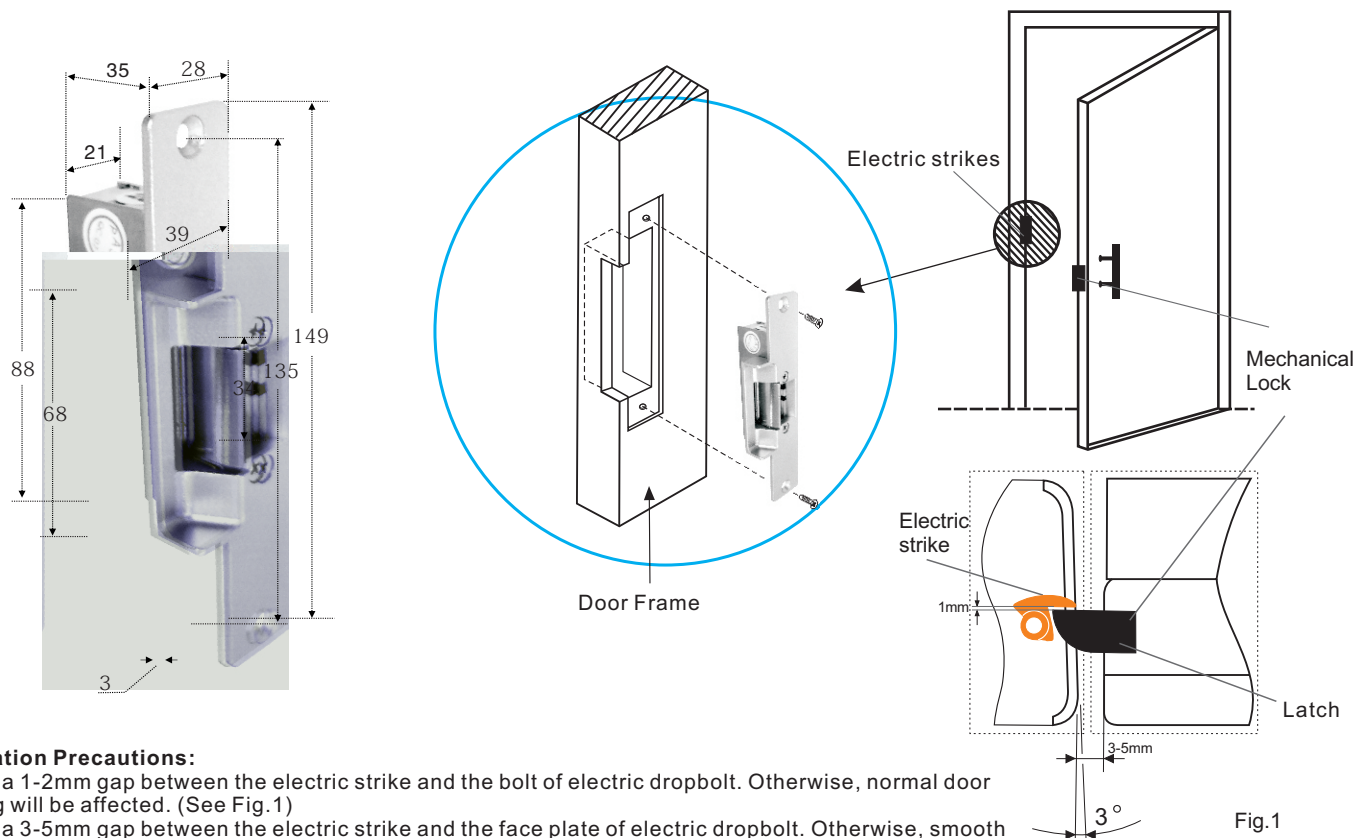

Installation Precautions:

1. Allow a 1-2mm gap between the electric strike and the bolt of electric dropbolt. Otherwise, normal door opening will be affected. (See Fig.1)
2. Allow a 3-5mm gap between the electric strike and the face plate of electric dropbolt. Otherwise, smooth door closing will be affected. (See Fig.1)

Fig.1

ELECTRIC LOCKS

AL-131 Series Electric Strike User Manual



Welcome to use Advanced Lock products. In order to protect your rights and interests, read this User Manual carefully before use. Please contact the dealer or the manufacturer in case of query.

Applicable Range: This lock is applicable for use together with anode mechanical lock or ball lock in office buildings, wooden doors, stainless steel doors, fire doors and entrance gate of residence community.

Product Advantage: Recessed type installation, pleasant-looking appearance, wide lock mouth and more extensive application. The electromagnetic part adopts high-quality magnetic materials and special processing workmanship to ensure normal use and no residual magnetism even after long time operation.

Door Opening: 90° and available for load of 400kg

Electrical Property: Users can select appropriate products with different models and functions based on the following table. Customization is available according to users' requirements.

Model	Voltage (DC)	Current (mA)	Unlock Method	Customization is available for products with 6-24VDC;
AL-131NO	12V ± 15%	240	NO - unlock by connecting power	
AL-131NC	12V ± 15%	120	NC - unlock by disconnecting power	

Wiring: 1. One diode is an accessory provided in the accessory bag. The diode is used to prevent bounce-back current and voltage produced during locking or unlocking from affecting the access control mainframe. Users can connect the diode to the wiring terminal in parallel.

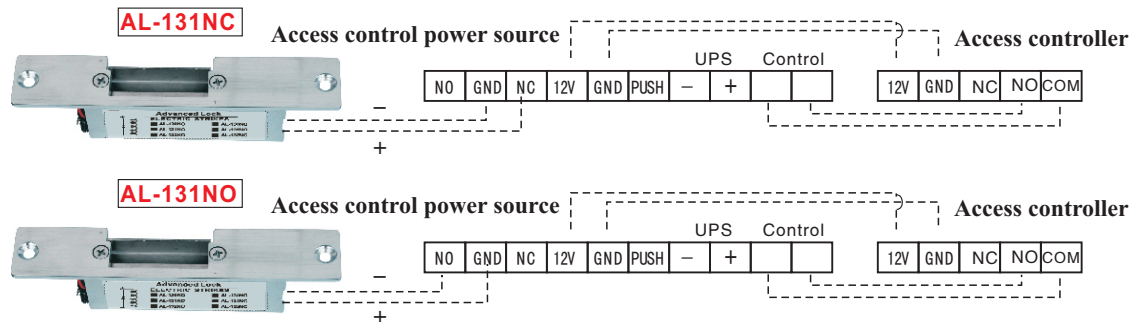

- Precautions:**
1. Read this User Manual carefully before installing the electric strike.
 2. Select qualified power source and wires to avoid insufficient locking force caused by abnormal power supply.
 3. This lock has no delay function. If delay function is necessary, it shall be used together with the controller.

AL-131 Series Electric Strike Installation Drawing

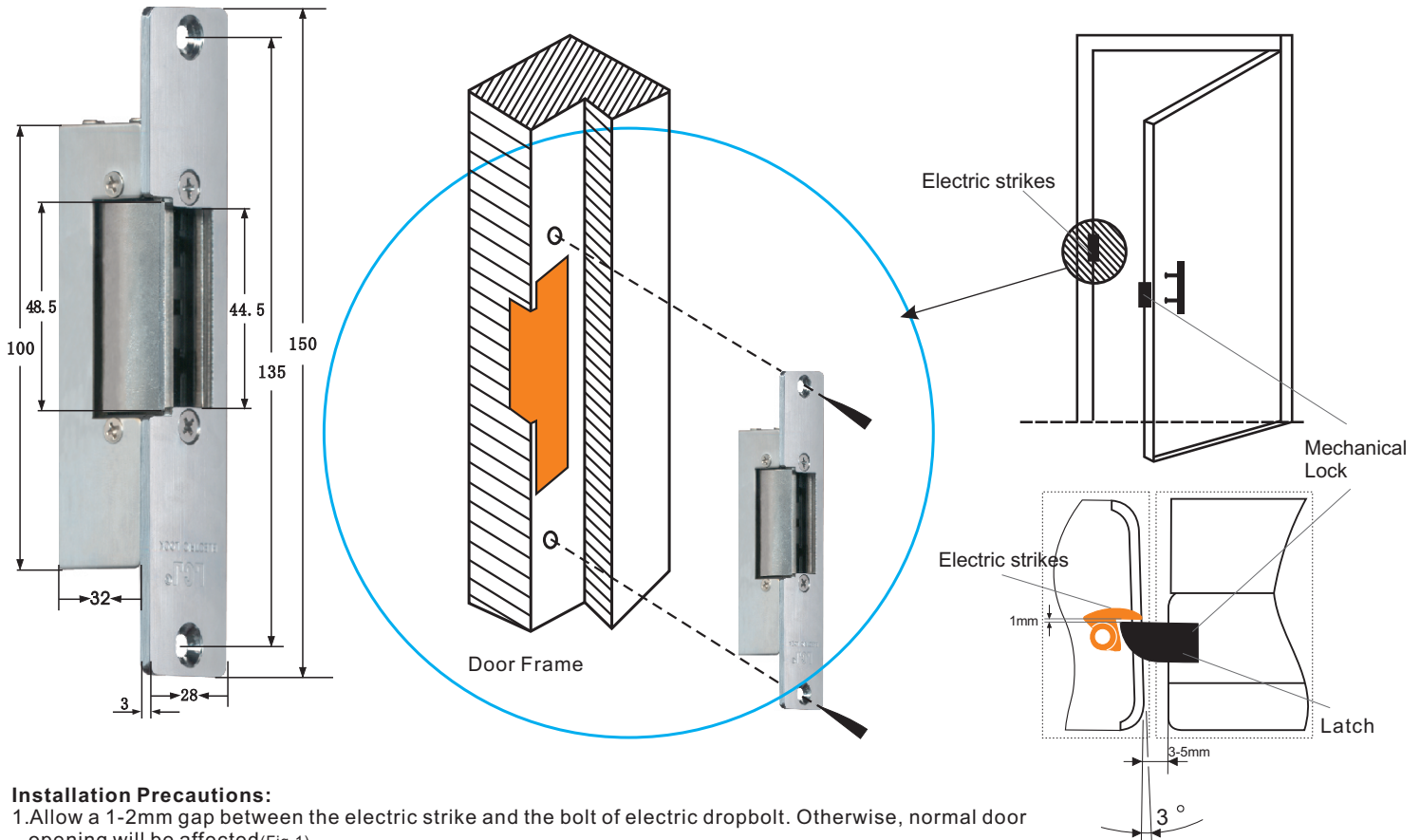
**Installation Precautions:**

1. Allow a 1-2mm gap between the electric strike and the bolt of electric dropbolt. Otherwise, normal door opening will be affected (Fig.1).
2. Allow a 3-5mm gap between the electric strike and the face plate of electric dropbolt. Otherwise, smooth door closing will be affected (Fig.1).

Fig.1

ELECTRIC LOCKS

AL-132 Series Electric Strike User Manual



Welcome to use Advanced Lock products. In order to protect your rights and interests, read this User Manual carefully before use. Please contact the dealer or the manufacturer in case of query.

Applicable Range: This lock is applicable for use together with anode mechanical lock or ball lock in office buildings, wooden doors, stainless steel doors, fire doors and entrance gate of residence community.

Product Advantage: Recessed type installation, pleasant-looking appearance, wide lock mouth and more extensive application. The electromagnetic part adopts high-quality magnetic materials and special processing workmanship to ensure normal use and no residual magnetism even after long time operation.

Door Opening: 90° and available for load of 400kg

Electrical Property: Users can select appropriate products with different models and functions based on the following table. Customization is available according to users' requirements.

Model	Voltage (DC)	Current (mA)	Unlock Method	Customization is available for products with 6-24VDC;
AL-132NO	12V ± 15%	240	NO - unlock by connecting power	
AL-132NC	12V ± 15%	120	NC - unlock by disconnecting power	

Wiring: 1. One diode is an accessory provided in the accessory bag. The diode is used to prevent bounce-back current and voltage produced during locking or unlocking from affecting the access control mainframe. Users can connect the diode to the wiring terminal in parallel.

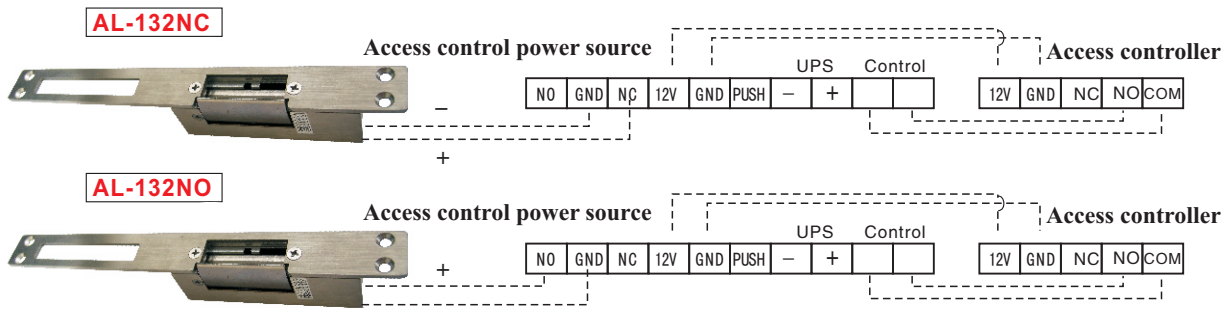

- Precautions:**
1. Read this User Manual carefully before installing the electric strike.
 2. Select qualified power source and wires to avoid insufficient locking force caused by abnormal power supply.
 3. This lock has no delay function. If delay function is necessary, it shall be used together with the controller.

AL-132 Series Electric Strike Installation Drawing

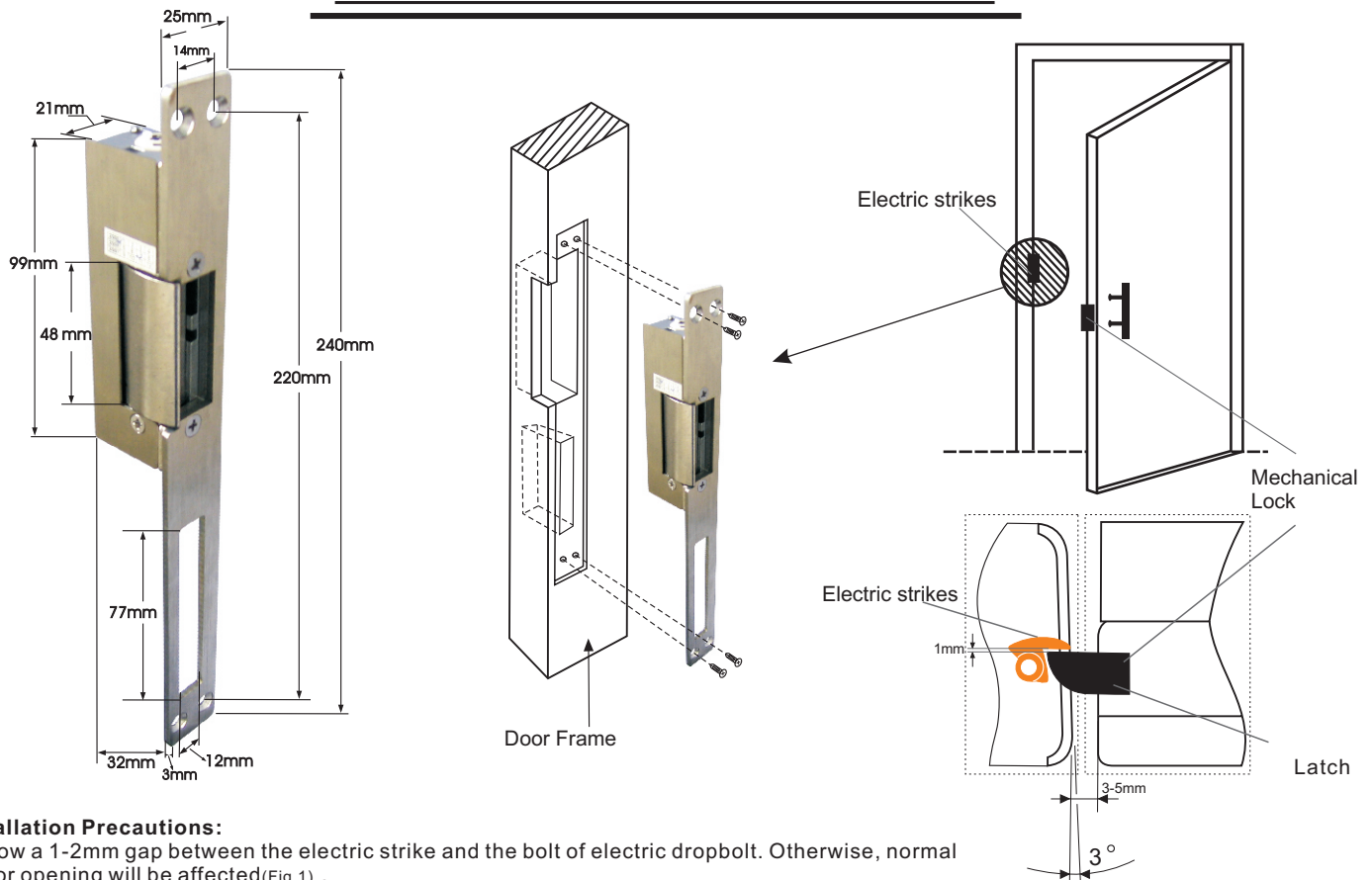
**Installation Precautions:**

1. Allow a 1-2mm gap between the electric strike and the bolt of electric dropbolt. Otherwise, normal door opening will be affected (Fig.1).
2. Allow a 3-5mm gap between the electric strike and the face plate of electric dropbolt. Otherwise, smooth door closing will be affected (Fig.1).

(Fig.1)

ELECTRIC LOCKS

AL-133 Series Glass Door Lock User Manual



Welcome to use Advanced Lock products. In order to protect your rights and interests, read this User Manual carefully before use. Please contact the dealer or the manufacturer in case of query.

Applicable Range: This lock is applicable for use together with anode mechanical lock or ball lock in office buildings, wooden doors, stainless steel doors, fire doors and entrance gate of residence community.

Product Advantage: Recessed type installation, pleasant-looking appearance, wide lock mouth and more extensive application. The electromagnetic part adopts high-quality magnetic materials and special processing workmanship to ensure normal use and no residual magnetism even after long time operation.

Door Opening: 90° and available for load of 250kg

Electrical Property: Users can select appropriate products with different models and functions based on the following table. Customization is available according to users' requirements.

Model	Voltage (DC)	Current (mA)	Unlock Method	
AL-133NC	12V ± 15%	240	NC-unlock by disconnecting power	

Wiring: 1. One diode is an accessory provided in the accessory bag. The diode is used to prevent bounce-back current and voltage produced during locking or unlocking from affecting the access controller. Users can connect the diode in parallel to the wiring terminal at the electric lock power input end.

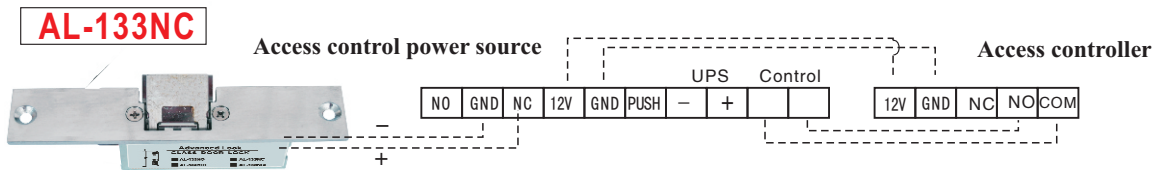

Precautions: 1. Read this User Manual carefully before installing the electric strike.

2. Select qualified power source and wires to avoid insufficient locking force caused by abnormal power supply (insufficient power).
3. This lock has no delay function. If delay function is necessary, it shall be used together with the controller.

AL-133 Series Glass Door Lock Installation Drawing

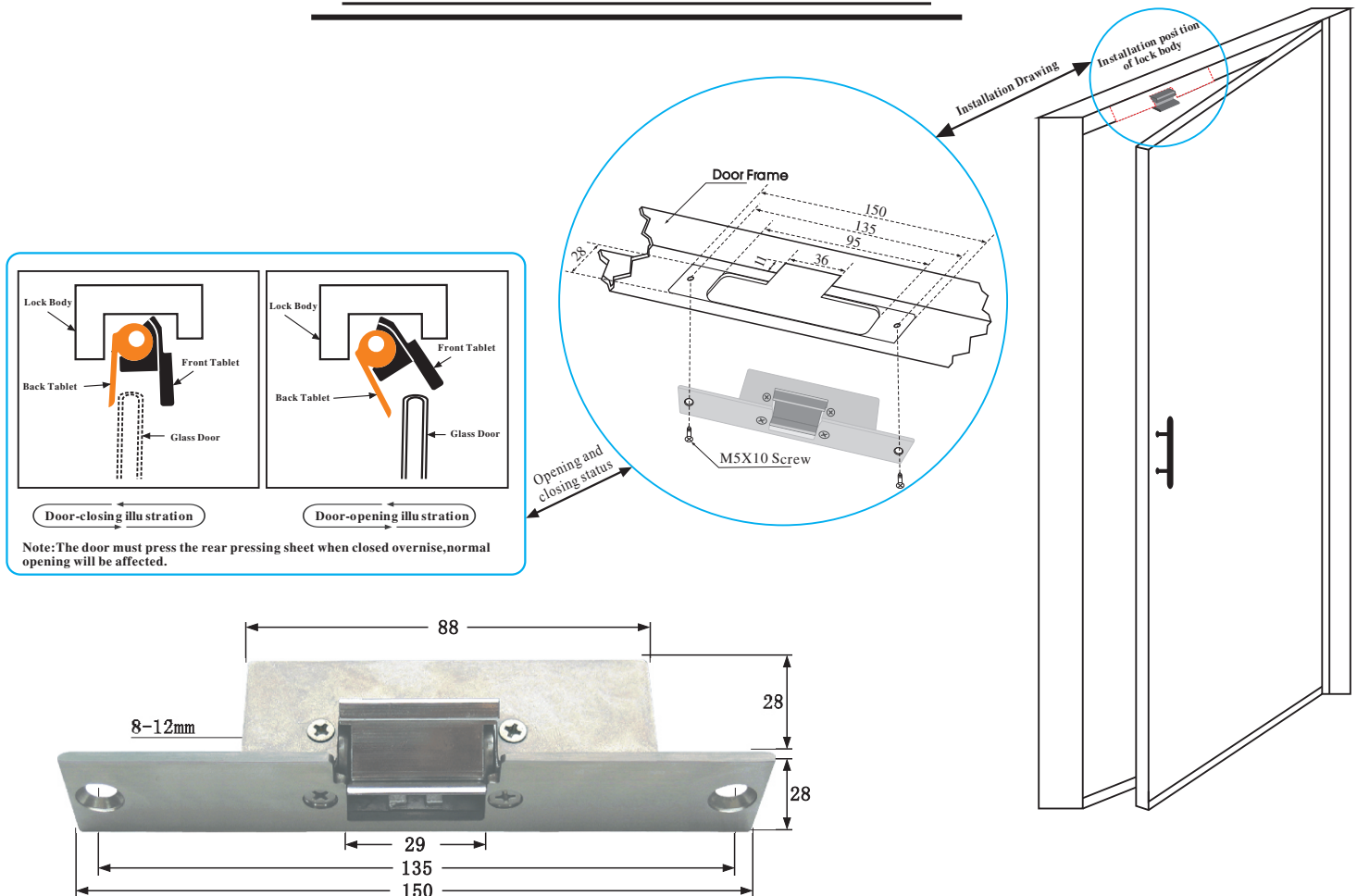

ELECTRIC LOCKS

Electric Bolt Lock User Manual



Welcome to use Advanced Lock products. In order to protect your rights and interests, read this User Manual carefully before use. Please contact the dealer or the manufacturer in case of query.

Applicable Range: This lock is applicable for office buildings and frame door at the entrance of residence community.

Product Advantage: Recessed type installation and pleasant-looking appearance. The electromagnetic part adopts high-quality magnetic materials and special processing workmanship to ensure no residual magnetism even after long time operation. This lock was designed and manufactured based on electronic, mechanical and mechanics principle to realize low-current operation and reduce rate of failure and maintenance. Auxiliary bracket can be used for installation of frameless glass door.

Door Opening: 180° and available for load of 1000kg.

Electrical Property and others: Users can select suitable products with different models and functions based on the following table. Customization is available according to users' requirements.

Model	Lock size (mm)	Voltage (DC)	Current (mA)		UnLock mode	Door signal	Lock Signal	With Ball Plunger	Indicator Lamp	Delay function
			Start-up	Working						
AL-100	200X35X38	12V ± 15%	350	350	Unlock by disconnecting power	Yes	/	/	NO	No delay function
AL-300	200X35X38	12V ± 15%	650	250	Unlock by disconnecting power	Yes	/	/	Yes	Adjustable at 0, 3, 6, 9 seconds (See Diagram 1)

Wiring: 1. **Power source:** Red wire is the positive (+) input end of the lock power source and shall be connected to positive end. Black wire is the negative (-) input end of the lock power source and shall be connected to negative end of the power source (12VDC).

2. **Door signal (conventional 2 wires configuration upon delivery):** Two white wires are used for door status signal [NO (normal open) indicates door opening status] output end. Limited current of door status signal is 300mA when the input voltage is 12VDC. Overload is forbidden. Door opening and closing status can be monitored after it is connected to the central control room.

3. The indicator lamp indicates working status of the electric lock and turns red after connected to power.

① **Door signal (nonconventional 3 wires configuration, customized):** When the door is under the opening status, the green wire, blue wire and orange wire refer to COM (common wire), NC (normal close) and NO (normal open) respectively. Limited current of door status signal is 300mA when the input voltage is 12VDC. Overload is forbidden. Door opening and closing status can be monitored after it is connected to the central control room.

② **Lock signal (conventional 2 wires configuration upon delivery):** When the door is under the opening status, the purple wire and light blue wire output NO (normal open) lock signals. The purple wire and orange wire output NC (normal close) lock signals. In case of 2-wire signal output (select only one between NO and NC), limited current of lock status signal is 300mA when the input voltage is 12VDC. Overload is forbidden. Locking and unlocking status can be monitored after it is connected to the central control room.

③ **Lock signal (nonconventional 3 wires configuration, customized):** When the door is under the opening status, the purple wire, orange wire and light blue wire refer to COM (common wire), NC (normal close) and NO (normal open) respectively. The purple wire and orange wire output NC (normal close) lock signals. Limited current of lock status signal is 300mA when the input voltage is 12VDC. Overload is forbidden. Locking and unlocking status can be monitored after it is connected to the central control room.

Remark: ①②③ can be customized.

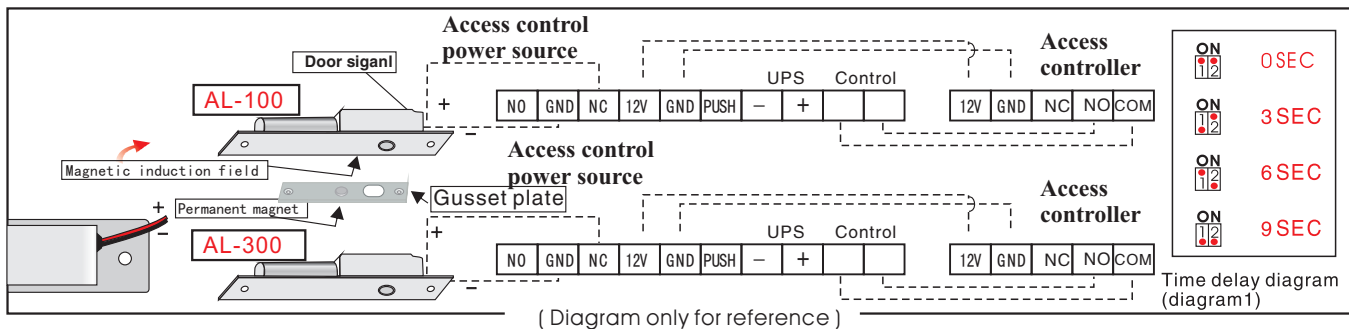

Standard packing list

Number	Item	Specification	Qty	Unit	Remark (s)	
1	Electric Bolt Lock	L200XW35XH38	1	PC		
2	Gusset Plate	L100XW30XH15	1	PC		
3	Cover metal Plate	L210XW40XH1	1	PC		
4	Fittings	Wood Sctew	M4X21	5	PC	Applicable to the fixed door lock, gusset plate. Fixed for metal doors, gusset plate.
		Machine Screw	M5 × 10	5	PC	
5	Manual Installation		1	/		
6	Certificate		1	/		

Component

Number	Series	AL-100	AL-300	Applicable Range	Remark (s)
1	Bracket	Upper Bracket	AL-200PZ	AL-200PZ	For upper frameless glass door
		Down Bracket	AL-100PF	AL-100PF	For down frameless glass door
2	Side mount bracket for hollow frame			For hollow door or hollow frame	The distance between glass door and door frame can not less than 7mm on frameless door. The distance between glass door and door frame can not less than 4mm on unilateral frameless door.

- Precautions:**
- Installation shall be conducted as per the User Manual and the installation drawing. Cut off the power during installation and wiring. Do not carry out wiring with power connected.
 - Select qualified power source and wires to avoid out of service of the lock due to abnormal power supply. It is recommended to connect the lock to the power source.
 - Make sure the installation position is proper and firm. Otherwise, the bolt will lock improperly and the lock will produce heat, leading to shortening of lock service life.
 - If the lock fails to work after the power is connected, check whether the permanent magnet is aligned to the magnetic induction area and check connection correctness of the electric circuit & power source. If the multimeter is used to measure the load, make sure that voltage at lock power input end shall not be less than 12VDC.

Diagram for Electric Bolt Lock Installation Procedures

(1) Installation Procedures

Note: Call us for installation method for hollow door and metal door.

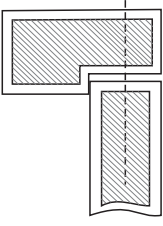
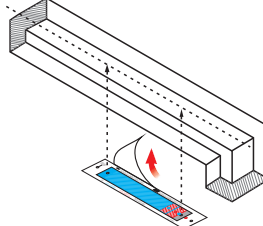
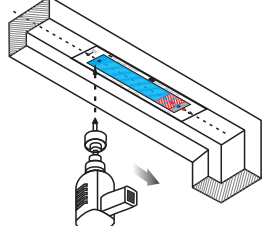
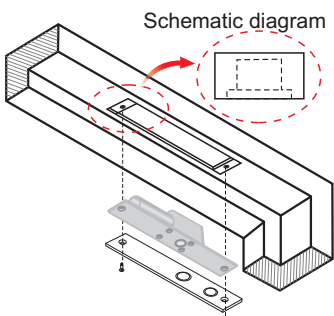
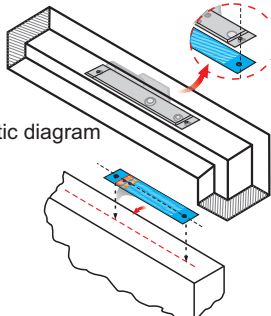
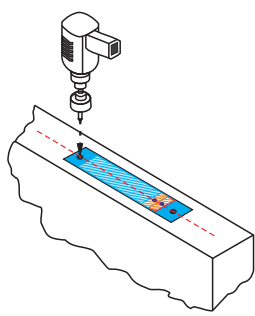
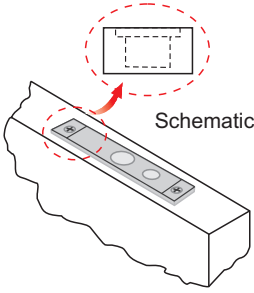
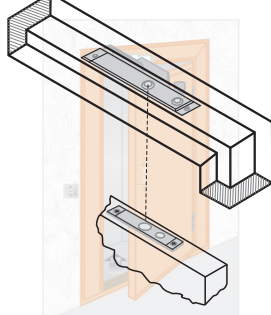
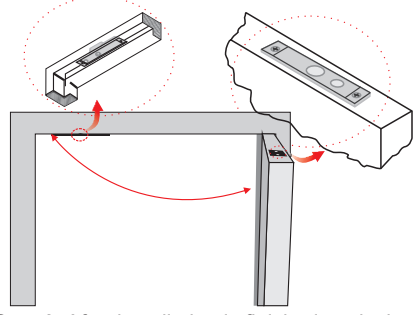
		
<p>Step 1: Firstly make sure the door is closed properly. Then decide the center line and mark on the doorframe and door leaf.</p>	<p>Step 2: Align the center line of perforated sticking paper to the center line on the doorframe. Then stick the paper on it.</p>	<p>Step 3: Use drilling tool to drill holes at positions corresponding to type of electric bolt lock.</p>
		
<p>Step 4: Fix the lock and the decoration plate on the doorframe based on the holes.</p>	<p>Step 5: Decide the center line according to the door, electric bolt lock and the bolt. Then stick the perforated paper to the door.</p>	<p>Step 6: Use special drilling tool to drill holes on relevant type of magnetic buckling plate according to corresponding electric bolt lock.</p>
		
<p>Step 7: Fix the magnetic buckling plate on the door with screws.</p>	<p>Step 8: Keep alignment between bolt center line and the center line of bolt hole on the magnetic buckling plate.</p>	<p>Step 9: After installation is finished, typical wooden door installation effect is shown in the diagram above.</p>

(2) Installation diagram

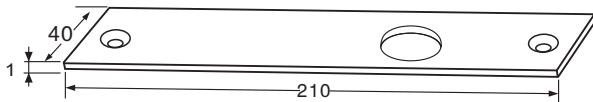

Cover metal plate

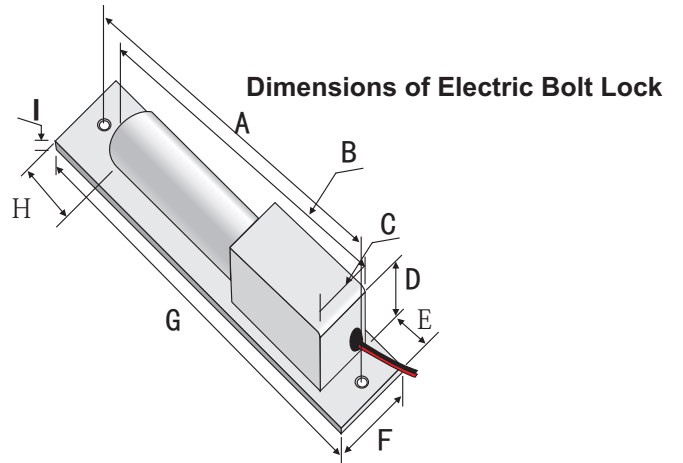

Dimensions of Electric Bolt Lock

Position Model	A	B	C	D	E	F	G	H	I
AL-100	180	155	29	35	23	35	200	21	3
AL-300	180	135	29	35	43	35	200	21	3

Magnetic Lock User Manual



Welcome to use Advanced Lock products. In order to protect your rights and interests, read this User Manual carefully before use. Please contact the dealer or the manufacturer in case of query.

Applicable Range: This lock is applicable for use together with building interphone and access control system. This lock is applied extensively in security door, emergency door and fire door.

Product Advantage: The magnetic lock adopts professional magnetic materials and special processing workmanship. No residual magnetism is produced even after long time operation. Long-time use will not cause magnetization of adsorption plate and result in reduction of adsorptive force. This lock has longer service life and is free of mechanical failure, abrasion and noise.

Auxiliary bracket can be used for installation of frameless glass door.

Door Opening: 90°

Electrical Property: Users can select suitable products with different models and functions based on the following table. Customization is available according to users' requirements.

Model	Dimensions (mm)	Voltage (DC)	Current (mA)	Indicator Lamp & Signal Output (NC/NO)
AL-180M	198X21X35	12V ± 10%	380	Not provided
AL-180	166X21X40		380	Not provided
AL-180D	332X21X40		760	Not provided
AL-280 (LED)	253X25X48	12V ± 10% 24V ± 10%	500/250	Provided
AL-280D (LED)	506X25X48		1000/500	Provided
AL-350 (LED)	253X28X55		500/250	Provided
AL-350D (LED)	506X28X55		1000/500	Provided
AL-500 (LED)	280X38.5X70		700/350	Provided
AL-500D (LED)	560X38.5X70		1400/700	Provided

Wiring: The positive phase and negative phase are connected to the power box. Use the model that has signal output.

Signals are connected as required by users:

1. Connected to COM and NO if normal open signals are necessary;
2. Connected to COM and NC if normal close signals are necessary;
3. The indicator lamp turns red if the lock is separated from the adsorption plate or if contact is not thorough. The lamp will turn green if the lock and the adsorption plate contact with each other correctly.
4. In case of abnormal indicator lamp when the lock is working, it may be caused by improper contact between the lock and the adsorption plate. Adjust the position of the lock and the adsorption plate to ensure thorough contact.

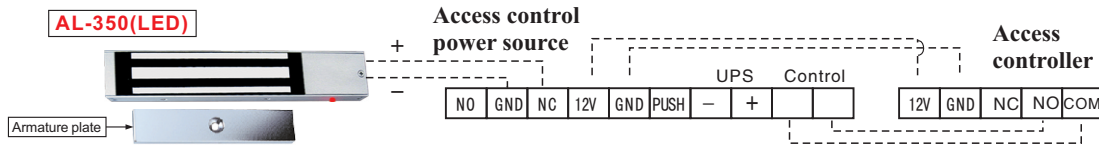

- Precautions:**
1. Cables shall be larger than 0.75mm² in case of power supply with a large power capacity (the output of power supply controlled within 12VDC ± 15% strictly).
 2. The screw connecting locks and Armature plate shall be tightened. Check the fixing of the lock and the board after three months.
 3. Install carefully to avoid damage to Armature plate and the galvanized coating of locks, and otherwise, the normal use, suction force and service life will be damaged.
 4. The complete contact between the Armature plate and the lock as well as the size of contact surface will decide the suction force directly.
 5. A rubber ring is required between the Armature plate and the lock so as to maintain a proper flexibility of the suck board, and tensile screws of the Armature plate shall not be fixed too tightly in order to maintain the appropriate flexibility of rubber ring.
 6. Armature plate cannot be welded on the door directly, and otherwise, the normal use of magnetic locks will be damaged.
 7. Wipe off rust-preventive oils on the locks with cotton cloth while alkaline or irritant detergents not allowed.

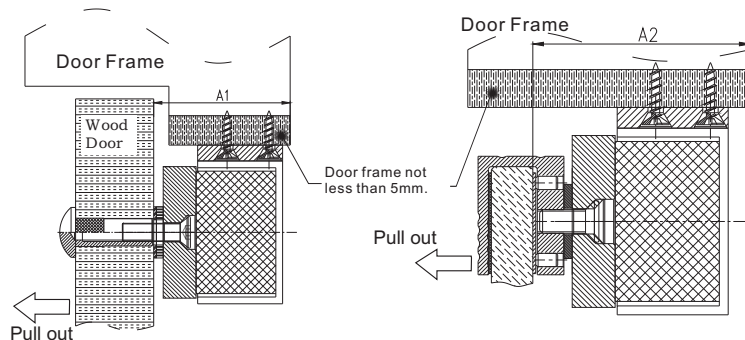

Series	Thickness (A1) (mm)	Thickness (A2) (mm)
AP-180	>38	>48
AP-280	>43	>53
AP-350	>46	>56
AP-500	>58	>68

10. During installation of this product, offset (toward right, left, upside and downside) of center position of both the adsorption plate and the lock shall not exceed 3mm.

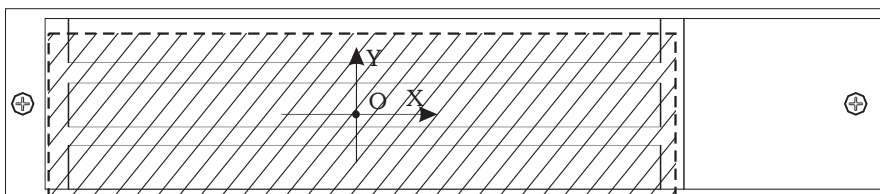

Direction	X(mm)	Y(mm)
Left	≤3	0
Right	≤3	0
Up	0	≤3
Down	0	≤3

Magnetic Lock Installation Drawing

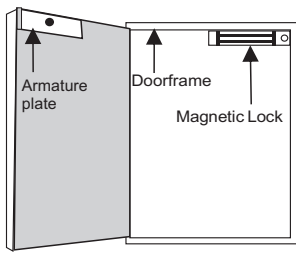

Pull out

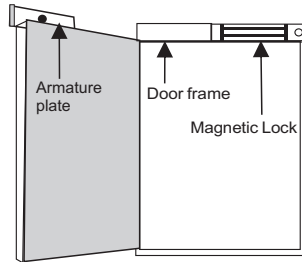

Push in

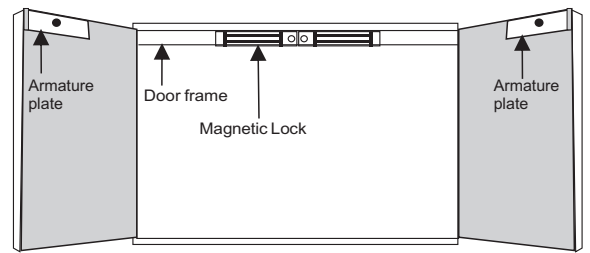

double-door pull out type

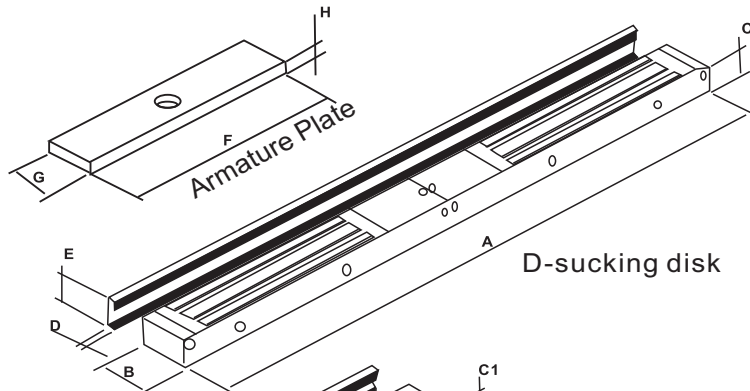

D-Sucking disk

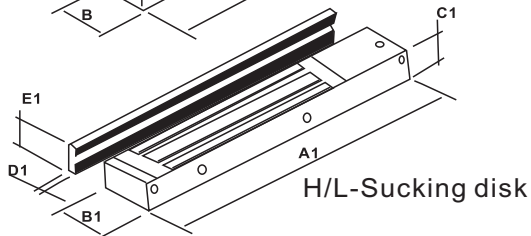

H/L-Sucking disk

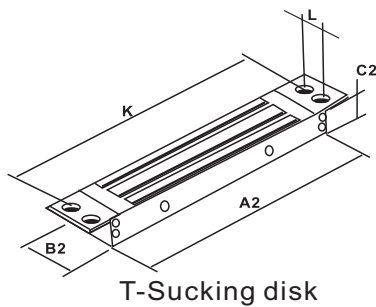

T-Sucking disk

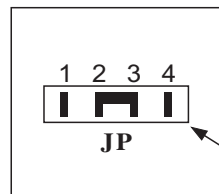

Diagram 3(24VDC)

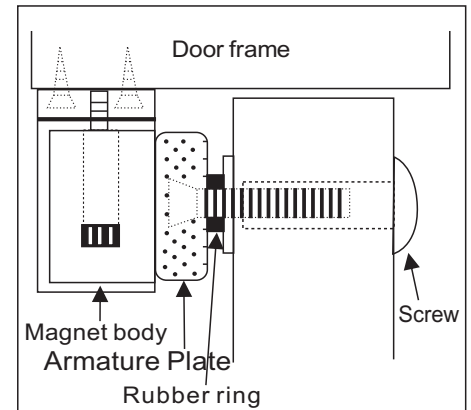

Diagram 2

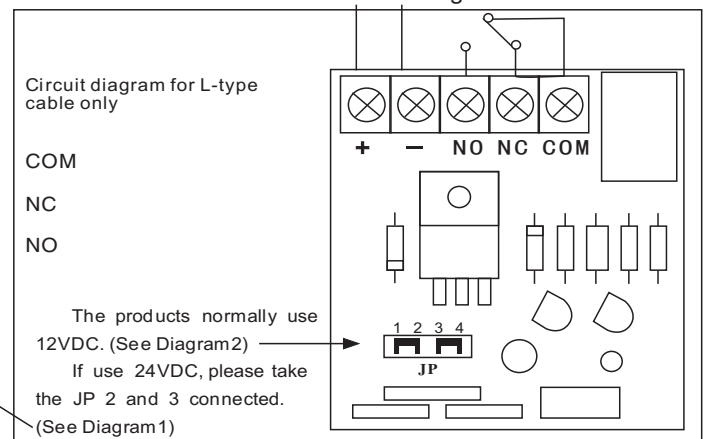

Diagram 1(12VDC)

Wiring Description (see Fig.1)

Precautions for installation of adsorption plate:

- 1.The rubber ring in the accessory bag must be installed between the adsorption plate and the door to ensure impulse force and balance the contact between each other.
- 2.The screw fixing the adsorption plate shall not be tightened excessively. Allow proper resilience for the rubber ring to make it available for adjusting the adsorption plate to the correct position so as to produce maximal adsorption force. (See Fig.2)

Series /Model		Dimension Identification								
		A	B	C	D	F	F	G	H	
D-Sucking Disk	AP-180D	332	35	21	6	21	130	32	11	
	AP-280D(LED)	506	42	24.5	6	24.8	185	38	12	
	AP-350D(LED)	506	48	27.5	6	27.3	185	48	12	
	AP-500D(LED)	560	70	38.5	7	37.5	184.5	58	14.5	
H/L Sucking Disk		A1	B1	C1	D1	E1				
	AP-180	166	35	21	6	21	130	32	11	
	AL-280(LED)	253	42	25	6	24.8	185	38	12	
	AP-350(LED)	253	48	27.5	6	27.3	185	48	12	
	AP-500(LED)	280	63	37.5	7	37.5	184.5	58	14.5	
T-sucking Disk		A2	B2	C2	D2	E2	F2			
	AL180M	166	35	21	198	20	182	130	33	11

Diagram of Magnetic Lock Auxiliary Bracket Installation Procedures (Inward-opening Door: AL-180PL,AL-180DPL, AL-280PL, AL-280DPL,AL-350PL,AL-350DPL, AL-500PL,AL-500DPL, AL-180PZ, AL-280PZ, AL-350PZ, AL-500PZ)

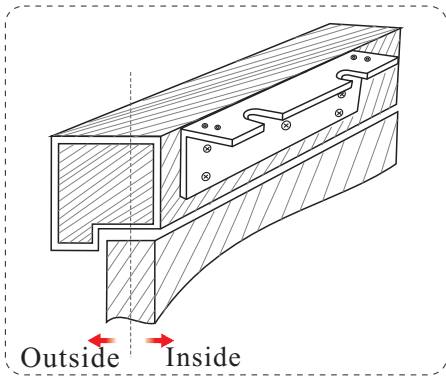

Step 1: Use cross screwdriver to fix the L-auxiliary bracket to the doorframe.

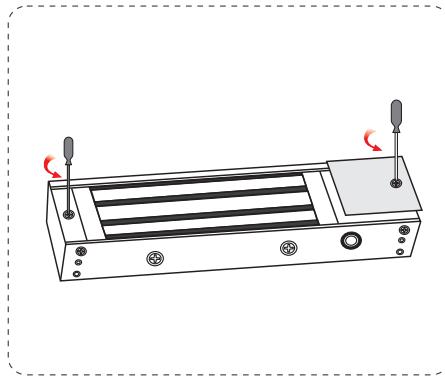

Step 2: Use cross screwdriver to dismount the anti-dismantle screw on the lock.

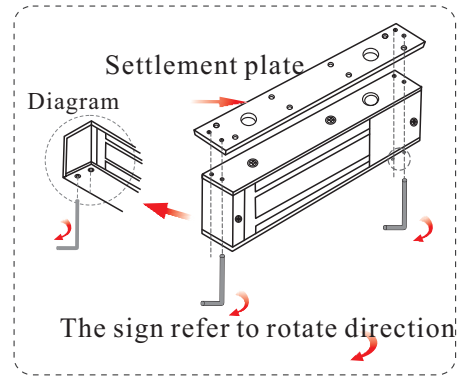

Step 3: Use Allen key to separate the connecting plate from the bottom of the lock. Be careful to hold the screw to prevent slipping.

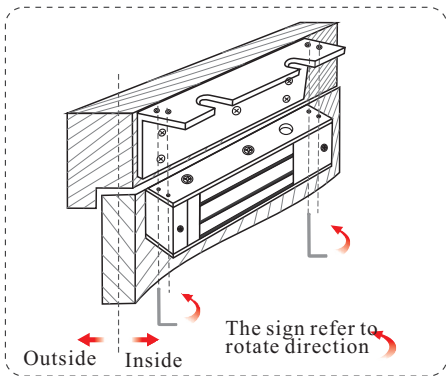

Step 4: Use Allen key to install the lock to L-bracket. Be careful to hold the screw to prevent slipping.

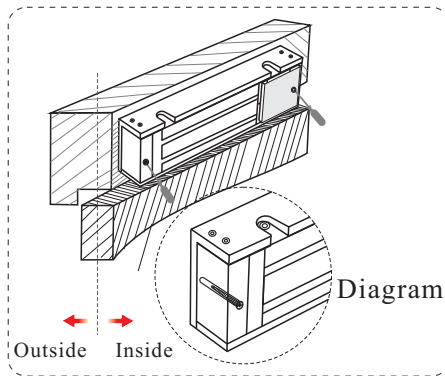

Step 5: Use cross screwdriver to mount the anti-dismantle screw onto the lock.

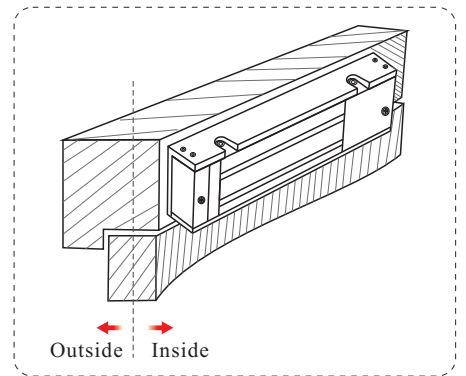

Step 6: Status of the lock after installation

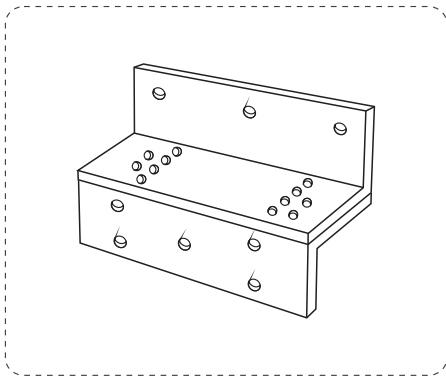

Step 7: Use cross screwdriver to assemble the Z-bracket.

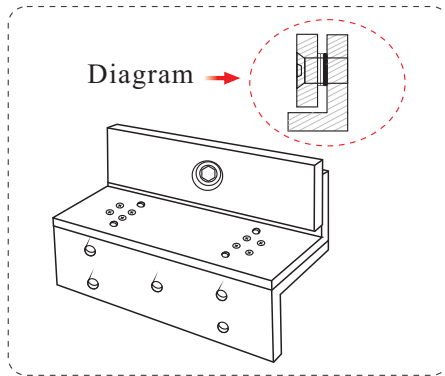

Step 8: Install the sub-plate to the Z-bracket (see schematic diagram in Fig.8).

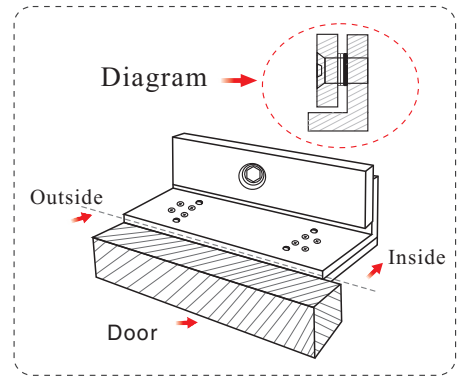

Step 9: Fix Z-bracket to relevant position on the door leaf. (Note: Keep tight contact between the sub-plate and the lock)

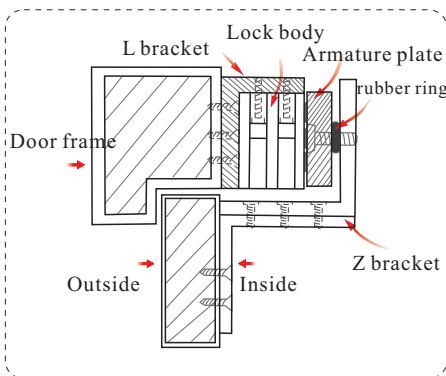

Step 10: Installation is finished.

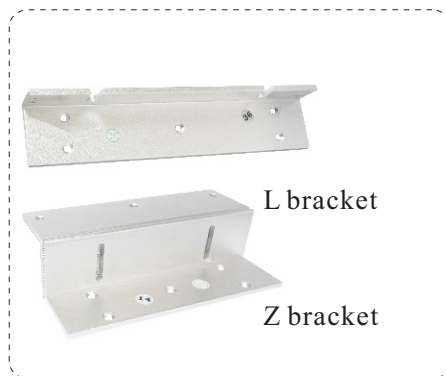

Note: The rubber ring must be installed to keep proper resilience (see Fig.10).

Position Model	Length	Width	Height
AL-180PL	166	26	50
AL-180DPL	332	26	50
AL-180PZ	131	40	100
AL-280PL	253	30	50
AL-280DPL	506	30	50
AL-280PZ	185	50	100
AL-350PL	253	30	50
AL-350DPL	506	30	50
AL-350PZ	185	50	100
AL-500PL	280	42	72
AL-500DPL	560	42	72
AL-500PZ	185	65	133

Diagram of Magnetic Lock Auxiliary Bracket Installation Procedures (Downside Frameless Glass Door: AL-180PU, AL-280PU, AL-350PU, AL-500PU)

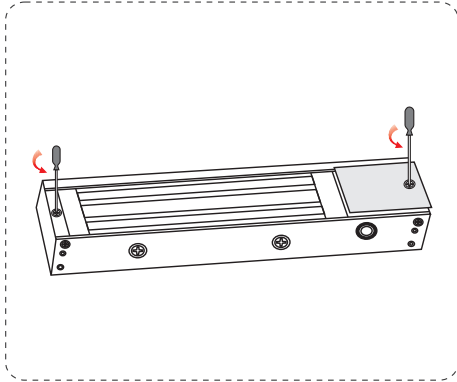

Step 1: Use cross screwdriver to dismantle the anti-dismantle screw on the lock.

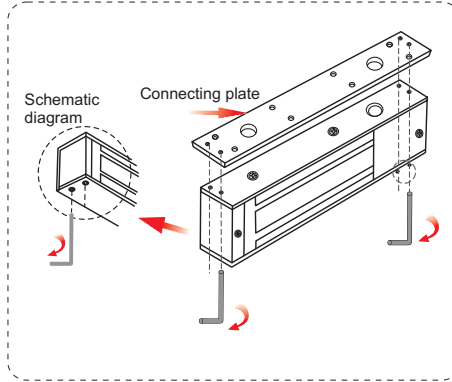

Step 2: Use Allen key to separate the connecting plate from the bottom of the lock.

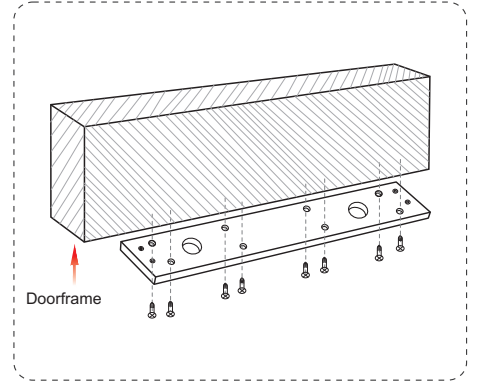

Step 3: Use screws to fix the connecting plate to the doorframe and fix relevant positions.

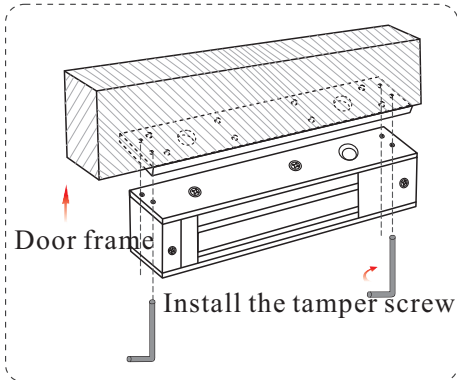

Step 4: Use Allen key to install the lock onto the doorframe connecting plate in corresponding position.

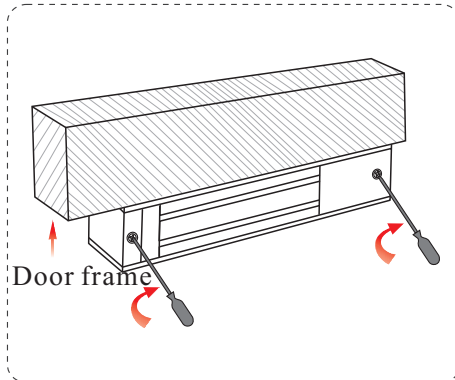

Step 5: Use cross screwdriver to install wire box cover and the anti-dismantle screws.

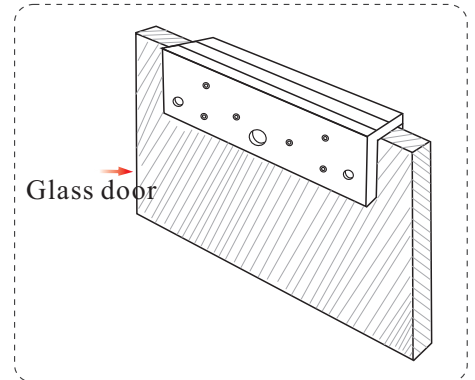

Step 6: Install U- bracket to the glass door and align it with lock position on the doorframe. Then fix it with screws.

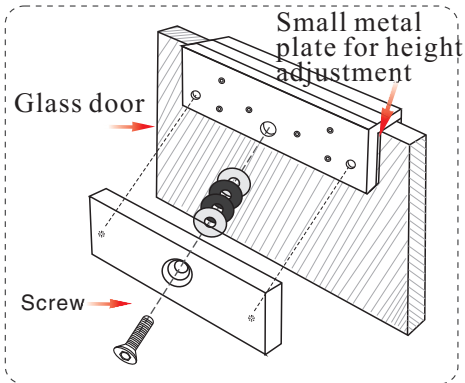

Step 7: Use screws to fix the sub-plate and the U- bracket. Their positions shall be consistent. Make sure the rubber ring is installed during installation.

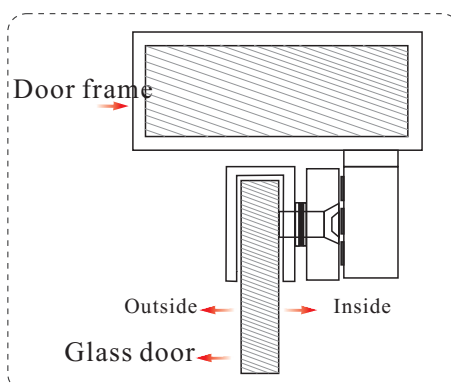

Step 8: Installation effect

Position Model	Length	Width	Height
AL-180PU	140	29	40
AL-280PU	195	29	40
AL-350PU	195	29	40
AL-500PU	198	42	66

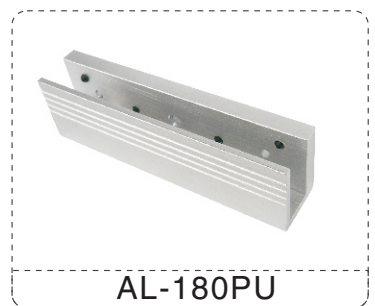
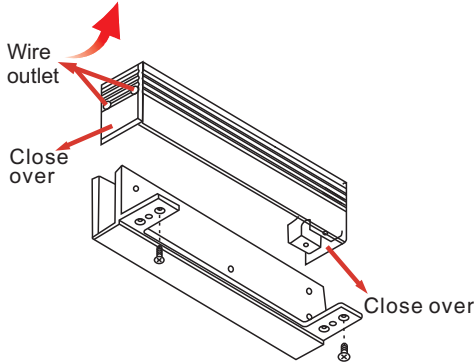
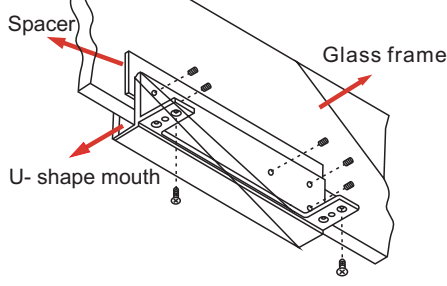

Diagram of Electric Bolt Lock Upward Bracket Installation Procedures (AL-200PZ)

- ① Use screwdriver to dismantle the screws under the upward bracket.



- ② The U- bracket clamps upwards the glass frame according to thickness (use spacer) of the glass door. After correction of the position, fix it on the glass frame.



- ③ Use screws to fix the cover and the L- bracket to the main frame.

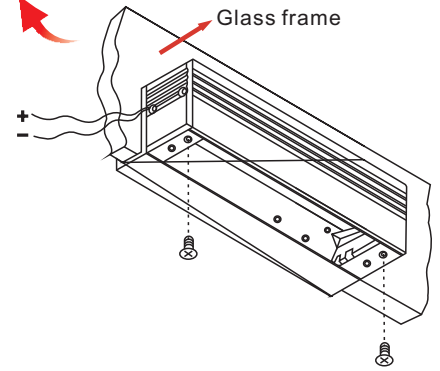

- ④ Clamp the lock and the U- bracket upwards to the corresponding position. Then use the screwdriver to fix it.

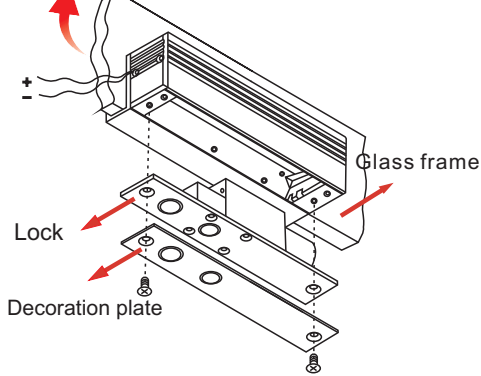

- ⑤ After assembling, the effect is as shown in Fig. 6.

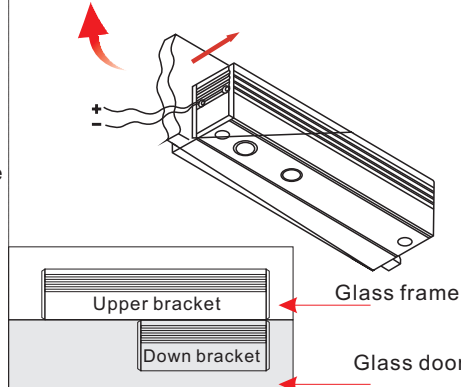

Note: In case both the upside and downside parts are frameless glass, the distance between glass door and doorframe shall not be less than 7mm; In case only one part is frameless glass, the distance between glass door and doorframe shall not be less than 4mm;



Position	Length	Width	Height
Model			
AL-200PZ	205	61	48

Diagram of Electric Bolt Lock Downward Bracket Installation Procedures (AL-100PF)

- ① Use screwdriver to dismantle the screws. Then dismantle covers on both sides.

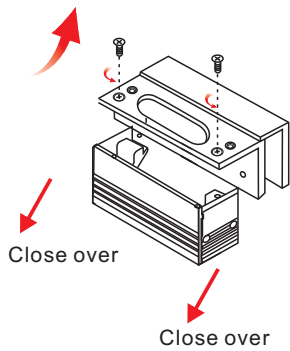

- ② Install spacer for downward U- bracket. Adjust the position and then fix it on the glass door with screws.

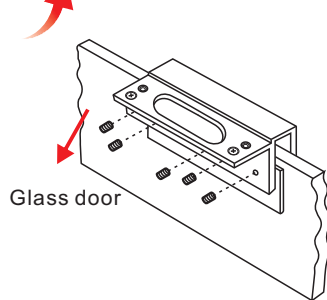

- ③ Assemble the dismantled accessory (cover) and then assemble it together with the U- bracket.

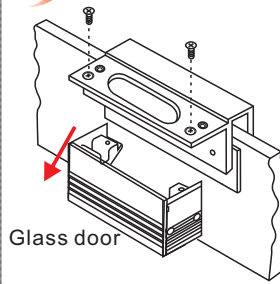

- ④ Fix it with screws.

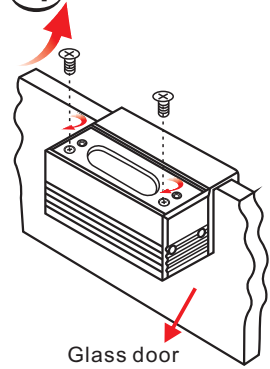

- ⑤ Fix the magnetic buckling plate on the bracket with screws.

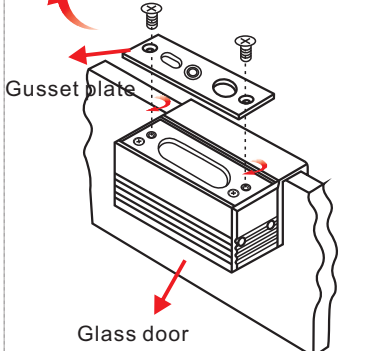

- ⑥ After assembling, the effect is as shown in Fig. 6.

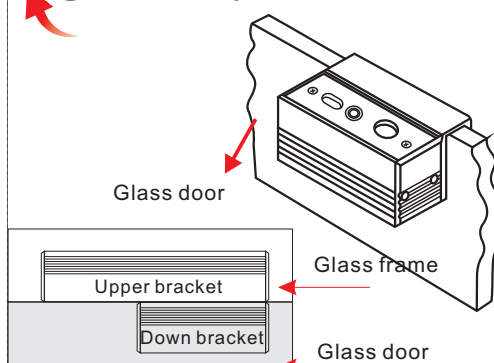

Note: In case both the upside and downside parts are frameless glass, the distance between glass door and doorframe shall not be less than 7mm; In case only one part is frameless glass, the distance between glass door and doorframe shall not be less than 4mm;



Position	Length	Width	Height
Model			
AL-100PF	106	61	48