

User Manual

ZKAIO1000

Version: 1.0

Date: May, 2018

Dear customers:

Please read the user manual carefully before printer operation.

Please keep this manual for reference.

1 Package Assembly

Following is all items you can find in your package:



(1) Cash register

(2) User manual

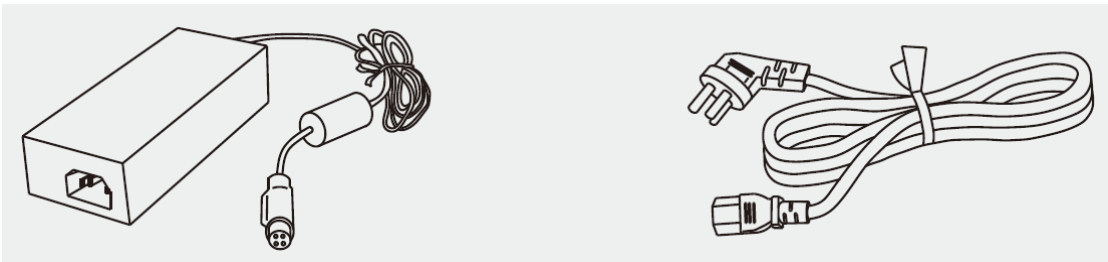

(3) Power adapter

(4) Power cable

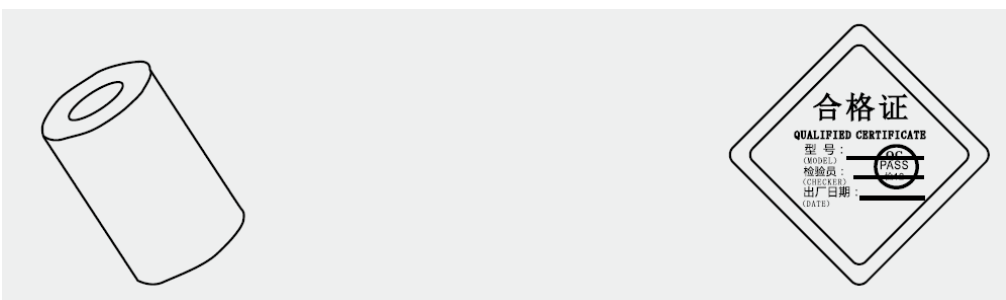

(5) Paper roll

(6) Certification

Introduction

A letter to customer

Personal safety is important when operating and maintaining.

Please read all safety warnings and cautions included in this manual carefully before operating and maintaining.

Do not maintain the device by yourself, if you meet any faults cannot be resolved under the instructions in this manual, please turn off power and pull out plug, contact us for help.

About

This manual aims for Android POS series.

The manual content and version are subject to change without prior notice.

Safety statement

The contents of this manual only apply to this device, all contents have been validated and reviewed.

The contents are subject to change without notice.

This product comply with GB4943.1-2011; GB9254-2008.

Warranty statement

Device must be opened by original factory person or qualified service person. Do not maintain device by yourself, otherwise warranty will be invalid.

Caution

- ✧ Please avoid radio interference.
- ✧ Please use original accessories and spare parts provided by our factory. And using unallowable improper spare parts may cause damage and malfunction.
- ✧ This product apply two-pole plug with ground connecting. Please make sure your the outlet voltage of board and the voltage product needs are the same.
- ✧ Keep the product, power and paper roll in a dry and cool place, avoid of direct sunlight and high temperature.
- ✧ Make sure all the ports are connected correctly.
- ✧ Please keep your communication device and the printer in the same LAN.
- ✧ The product should be place horizontally.
- ✧ Please turn off before you do the cleaning.
- ✧ Protect the power cable and the power-supply device, avoid damage and life-unsafety.
- ✧ Make sure you turn off the printer before the replacement.
- ✧ In these situation, quickly cut off the power:
 1. Power cable has been damaged.
 2. Liquid has been pulled on the interface.
 3. Strongly impact.

2 Button and Interface

Indicator and buttons

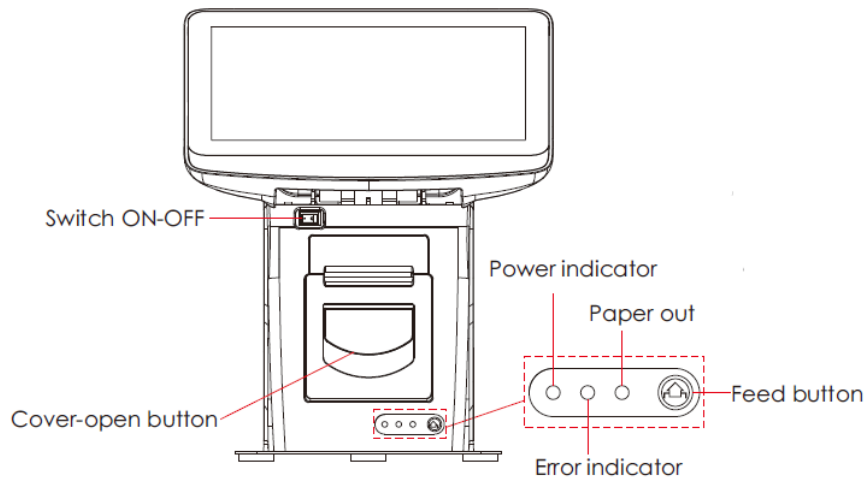

Host control button

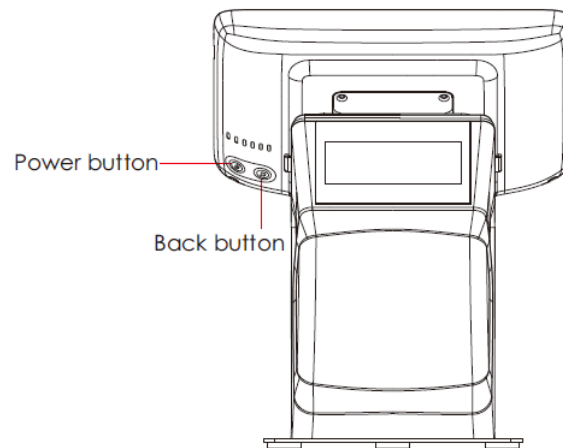

Indicator and button	Description
Power indicator	Shows power status. Blue light when power is on
Error indicator	Red light flash when errors occurs
Paper out indicator	Red light flash when out of paper
Feed button	Paper feed operation
Switch ON-OFF	Control the power of the printer
Cover-open button	To open the cover and change paper roll
Power button	To control the host of cash register
Back button	Return to previous menu

Host Interface

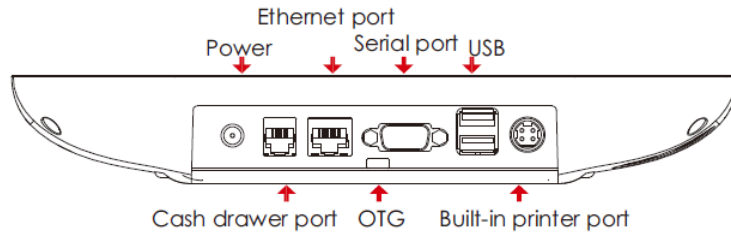

Interface	Description
Power	For power input
Ethernet	100M LAN, RJ-45 module connector RJ11interface, Dual 12V connector cash drawer
Serial port	RS232, D-SUB 9 PIN
USB	Support USB V2.0/1.1
Cash drawer	RJ11interface, Dual 12V connector cash drawer
OTG	For system adjusting
Built-in printer	Supply for build-in printer

Cash drawer interface



Warnings

This interface is only allowed to cash drawer, do not connect with mobile phone or any other device, otherwise these device will be damaged.

The working voltage of the cash drawer should be 12V.

The interface is standard RJ-11, 6 pins socket, output DC12V/1A.

The functions of pins shows below:

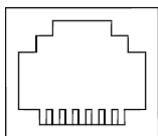

654321
RJ-11

PIN No.	Signal	Flow
1	Ground	Null
2	Cash drawer drive 1	Output
3	Cash drawer switch	Input
4	+12V	Output
5	Cash drawer drive 2	Output
6	Ground	Null

3 Media Loading

1. Press the cover-open button, open the cover of the printer.

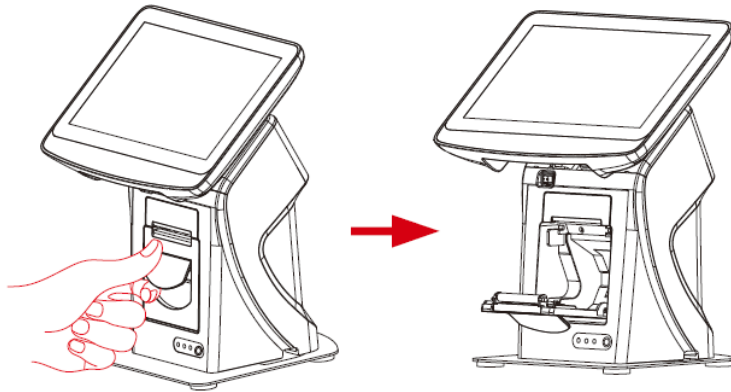

2. Load paper roll into the printer, pull out the paper roll till it pass gap sensor, complete paper loading.

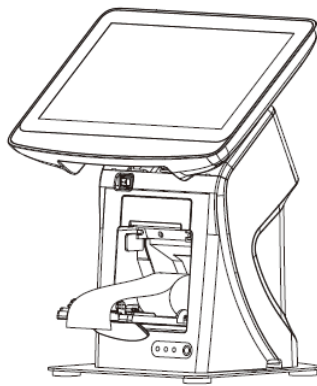

3. Carefully close the cover.

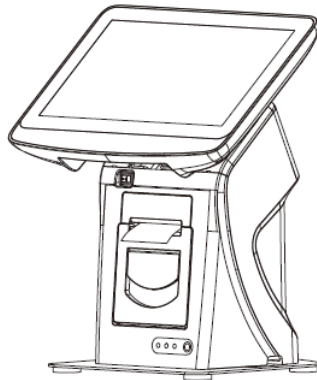

4 Power Cable Connection

1. Pull the uncover button, then, there is a host uncover button inside. After that, drag down the host uncover button until separates the whole into two parts.

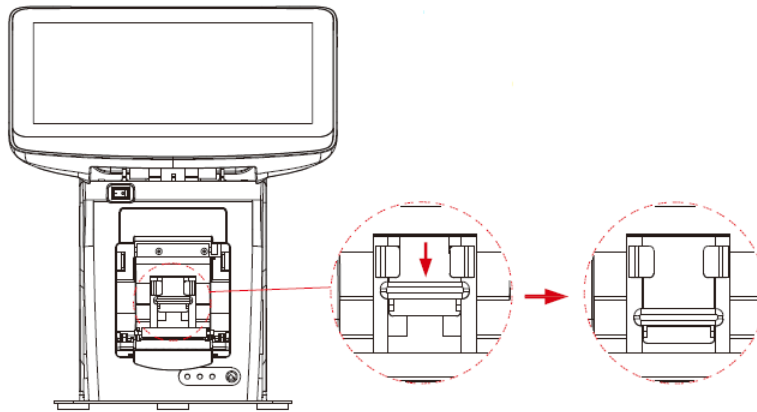

2. Place the cable in between, and connect it by the way according the graph below.

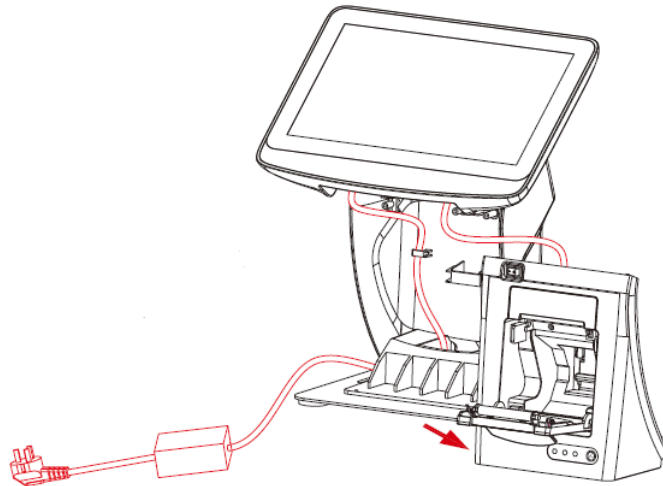

3. Place the printer back into its host, and then, button it up and lock it.

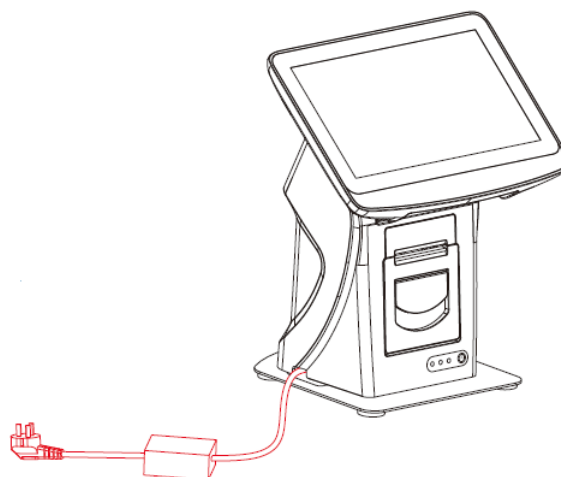

The routing way between the cables that connected with host and power cable are the same.

5 Troubleshooting

Cannot start device, power indicator off.
1. Check whether power socket works. 2. Check whether cable plugs tightly.
Printer keeps beeping, fails to print.
1. Check whether the cover closed well. 2. Check whether the paper is out of. 3. Check whether the LED is still light.
No noise, the printer cannot print.
1. Check whether the printer is opened.
Receipt is printed unclearly.
1. Turn off power, swab the print head with medical alcohol.

6 Maintenance

<ol style="list-style-type: none">1. Avoid directly sunlight, dust and water etc.2. Keep away from electromagnetic filed3. The device should in well power condition, if not, please give a independent power supply.4. Do not shake or kick the device.5. Please do not remove and add any device for it. And do not move device frequently6. Keep device clean. Do not wipe body with wet clothes or chemicals (For example: gasoline, thinner etc).7. Turn off the power immediately once after the problem occurred. Do not maintain and disassemble by yourselves.8. Check the cable connection temporary, make sure they are fully connected.9. Please cutoff the power, if you are not going to use it for a while.
--

Warranty Card

User profile:

Product name		Date	
		Seller name	
P/N		Seller contact number	
User name		Fax. No.	
User address		Postcode	
Contact number		Email	

Record

Date	Description	Finished date	Signature

Warranty instruction

Dear customer,

Thanks for your patronage! In order to protect your rights and provide you a better service, our company comes out our efficient warranty service for you. Please read the ordinates carefully! We are looking forward to your suggestions!

1. There is a 12-month warranty start from when you purchase for this product. If your printer have been purchased for more than 12 months, you need to pay for your repair ments.
2. Please make sure your printer is packed in cartons and packing sound. Our company is not going to be responsible for the damages which are in transit.
3. The following are not include in your warranty:
 - 3.1 Human damages.
 - 3.2 Have not followed the instruction to set up.
 - 3.3 The fragile label has been broken.
4. Please read the user manual carefully before your set up.
5. To protect your rights, please take notes for where and when you purchase from.

ZK Building, Wuhe Road, Gangtou, Bantian, Buji Town,
Longgang District, Shenzhen China 518129

Tel: +86 755-89602345

Fax: +86 755-89602394

www.zkteco.com

