

INSTALLATION GUIDE

Full Height Turnstile

Applicable Models: FHT 2000 series

Chapter 1 Install the device

1. Cutting a slot in proper position, embedded pipe. The power cable will pass through the pipe when install the device.
2. Put the mounting drawings on the floor.
3. Using a hammer drill to perforate M12 screw holes according to the hole position shown in the drawing.
4. Installing the screw according to the screw holes.
5. Put the frames on the screw holes and fix up with M12 screw.

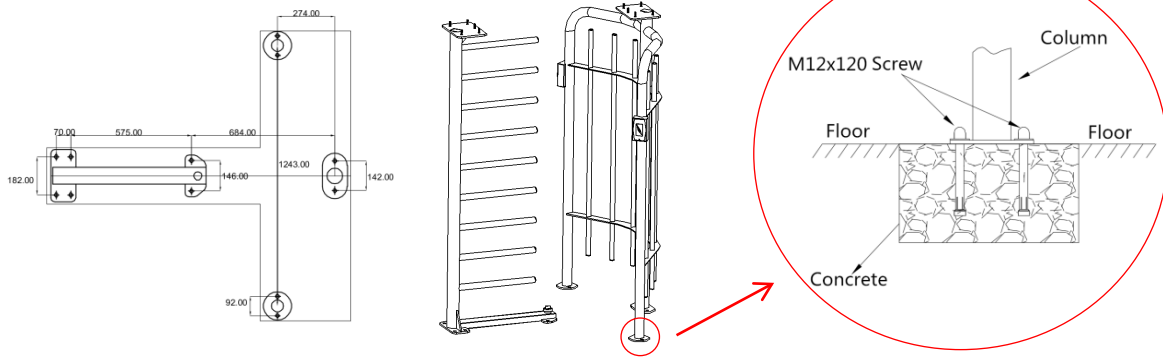

6. Put the chassis on the frame and fix up with M10 screw.

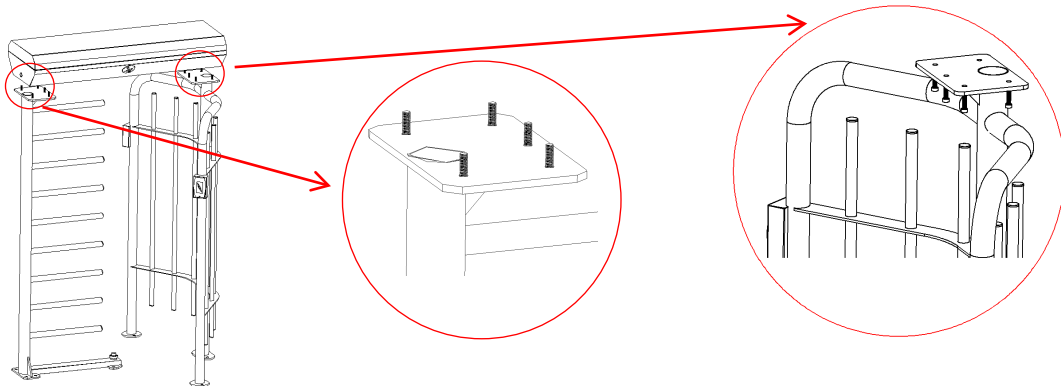

7. Put the whole rotating part in the middle of the frame and chassis and then fix up with screw and connection block.

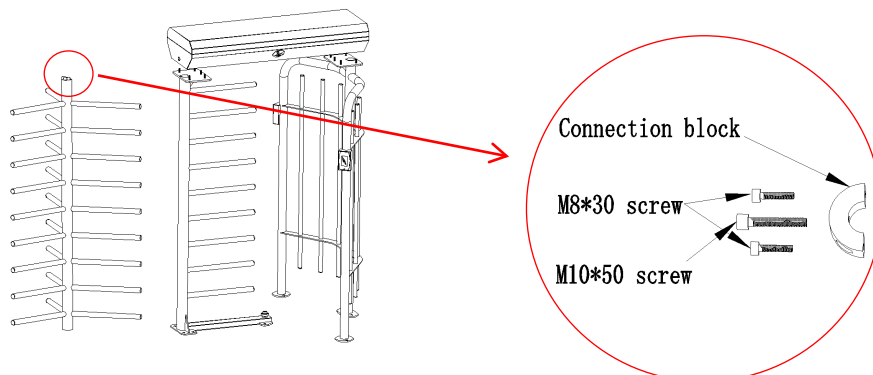

Chapter 2 Wiring diagram

1. Open the top cover to connect the corresponding interface. The power line and reader lines are hidden in different column. The wiring diagram is shown below. The reader lines are connected to READER2 and READER4.

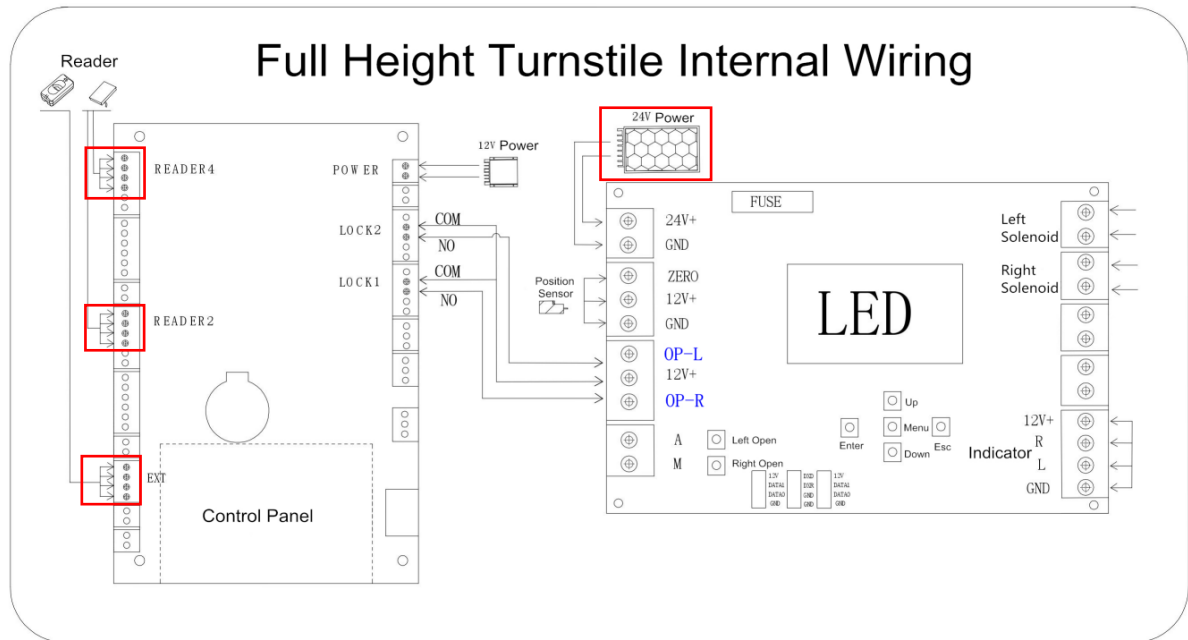

2. After the installation of the whole device, connect power to test. If the direction is contrary. Exchange the interface between READER2 and READER4.
3. If there is a slight tilt of the central column, slightly adjust the position of the movement.