

Installation Guide

License Plate Recognition Integrated Machine

Version: 1.0

Date: May, 2017

1. Installation Tools

Inner hexagon spanner, ground drill (the latter is not delivered with the product).

2. Safety Precautions

Carefully read this installation guide before installing and using the product. After the installation is complete, strictly check the terminal connection according to the wiring terminal diagram.

3. Structure

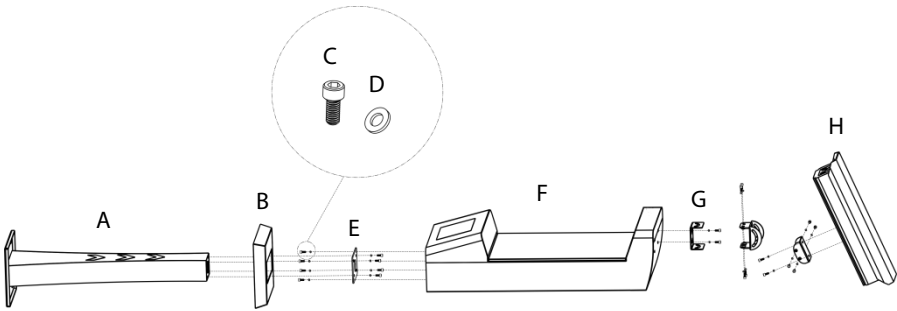

4. Parts List

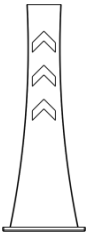

A Base support

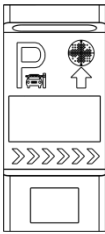

F Upper device body



C M6 screws

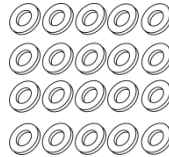

D Shim

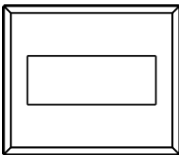

B Base cover

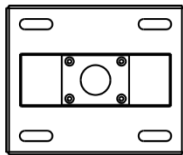

E Metal sheet for fixing

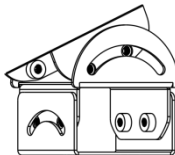

G Cardan joint

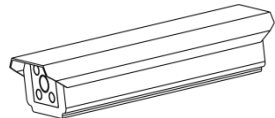

H Camera

5. Installation Location

It is important for the integrated machine to quickly and accurately output license plate recognition results and capture high-quality license plate pictures. Therefore, the installation location of the integrated machine aims to ensure that complete and clear license plate pictures are captured.

● Installation on a straight lane

A straight lane is an ideal installation environment for capturing high-quality pictures when vehicles move to the recognition area.

- 1) The integrated machine and the barrier gate can be installed on the same side of the lane but the integrated machine must be installed in front of the barrier gate with the gap of no less than 30cm, so as to avoid mutual interference.
- 2) When video recognition is adopted, the optimal distance between the recognition area and the integrated machine is 3.5~4m.
- 3) When video and ground sense recognition is adopted, the optimal distance between the ground coil and the integrated machine is 3.5~4m.

● Installation on a broad lane

- 1) If a lane is too broad, the moving directions of vehicles are not straight and vehicle heads may lean left or right, which may affect the recognition effect. You can divide the lane into two lanes or use barriers such as cone buckets or road piles to mark out a non-motor vehicle lane so that the motor vehicle lane becomes narrow and the vehicle movement direction is straight.
- 2) If a lane is too board but cannot be divided into two lanes or no non-motor vehicle lane can be marked out, for this situation, we can install two cameras, that is, install one camera on each side of the lane. In this way, license plates can be captured and recognized no matter whether vehicles lean left or right.
- 3) If a lane is very short, vehicles usually lean to one side when they move from one direction. In this case, install the camera on the side to which the vehicle heads lean. Then, the vehicle heads face right the camera. When vehicles can move from both directions, install one camera in each direction to capture license plate pictures.

● Installation on a curve lane

When the device is installed on a curve lane, vehicles move to the external side of the curve. Therefore, the integrated machine shall be installed on the external side of the curve. In this way, when vehicles move to the recognition area, the camera can capture the front view of the license plates.

● Installation in an underground garage

When installing the integrated machine in an underground garage, follow the principle below:

- 1) **Entrance:** Install the integrated machine on the horizontal road above the ramp of the underground garage.
- 2) **Exit:** Install the integrated machine on the horizontal road below the ramp of the underground garage.

In this way, when the integrated machine fails to recognize a license plate and the barrier gate cannot be opened, the vehicle will not stop on the ramp of the underground garage.

6. Installation Procedure

- 1) Insert the base cover into the base support.

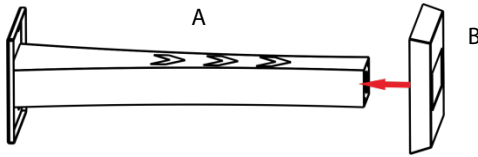

- 2) Fix the metal sheet for fixing on the base support and install the screws (with Shim).

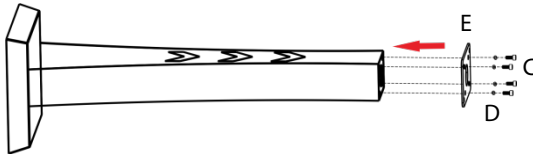

- 3) Fasten the upper device body on the base support and install the screws (with Shim).

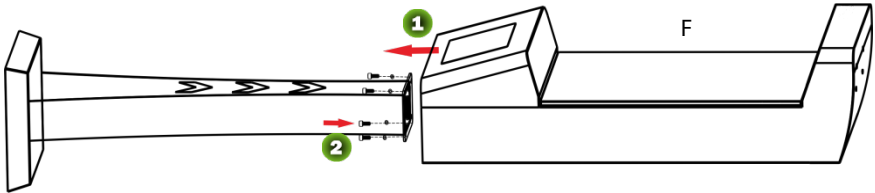

- 4) Erect the entire body and install it at the installation position for fixing.

- 5) Fasten the cardan joint and install the camera.

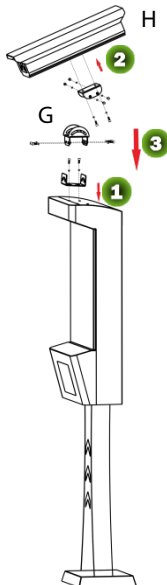

7. Cable Connection Description

1) Wiring terminal diagram

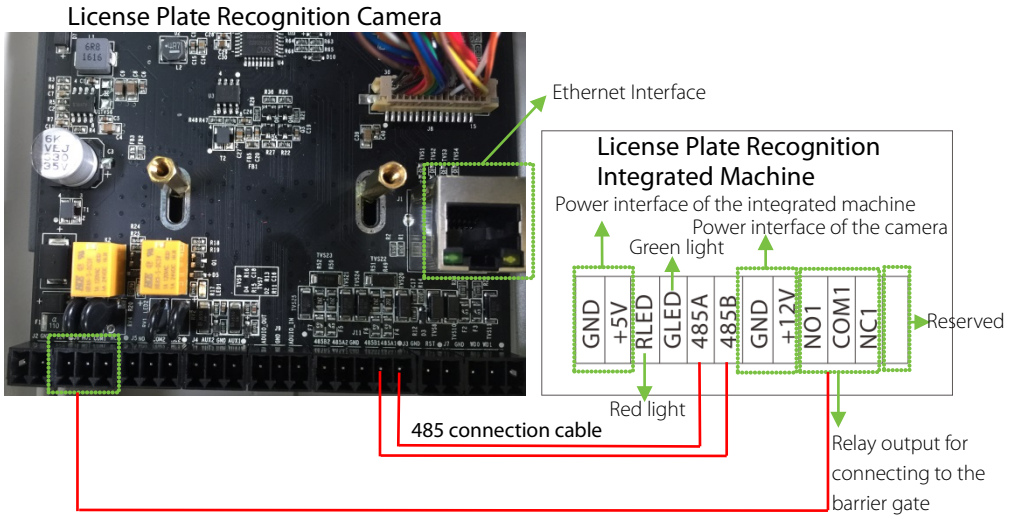

2) Port description

Pin	Wire	Usage
GND	Black	Power interface of the integrated machine
+5V	Red	
RLED	Red	Red light
GLED	Green	Green light
485A	Green	For connecting to the 485A1 and 485B1 ports of the camera
485B	White	
GND	Black	Power interface of the camera
+12V	Red	
NO1	Green	Relay output for connecting to the barrier gate
COM1	Red	
NC1	Blue	
		Reserved

